

LOC		DIST		REVISIONS			
P	LTR	DESCRIPTION	DATE	DNW	APVD		
T		REV PER ECO-15-016251	13NOV15	KG	CD		

1. THIS RECEPTACLE WILL MATE WITH ANY 9C4, SIZE 3 PLUG IN AMPLIMITE SERIES.
2. MAXIMUM WIRE INSULATION TO BE USED WITH THIS RECEPTACLE IS $\phi.072$.
3. THIS CONNECTOR ACCEPTS (4) POWER 8, OR COAX SOCKET CONTACTS IN POSITIONS A1 THRU A4, PURCHASED SEPARATELY. WILL NOT ACCEPT WILL NOT ACCEPT RIGHT ANGLE COAX.
4. THIS CONNECTOR ACCEPTS SIZE 20 SOCKET SIGNAL CONTACTS IN POSITIONS 1 THRU 5, PURCHASED SEPARATELY.

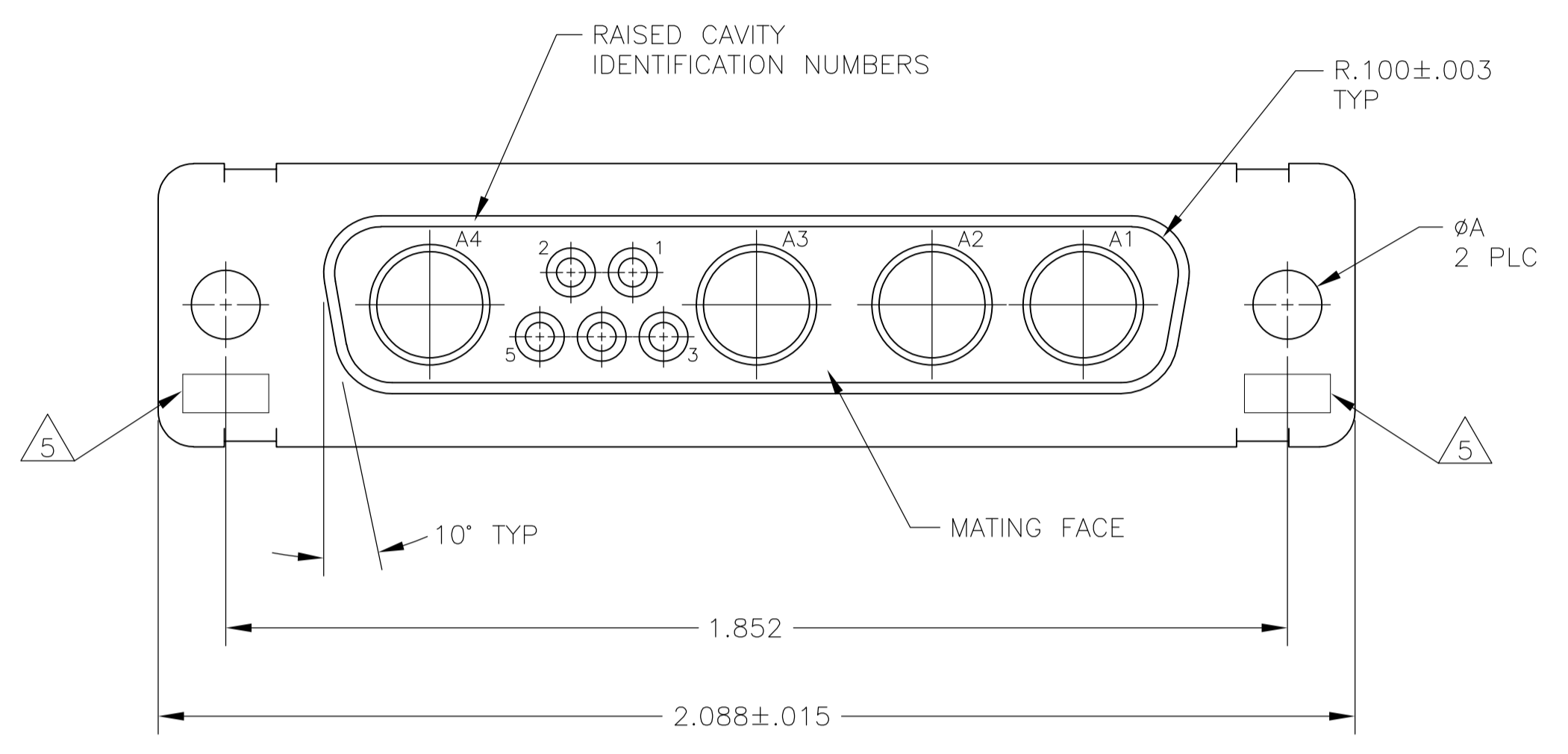

- 5 UL/CSA DESIGNATION STAMPED IN THIS AREA, OPTIONAL.
- 6 STEEL PER ASTM-A-109.
- 7 BRASS PER MIL-C-50 AND ASTM-B-36 UNS NO. C26000.
- 8 CADMIUM PLATED PER QQ-P-416, TYPE II, CLASS 2 OVER COPPER PER MIL-C-14550, CLASS IV.
- 9 GOLD PLATED PER MIL-G-45204 TYPE II, GRADE C, CLASS 1 OVER COPPER PER MIL-C-14550, CLASS IV.
- 10 FINISH: TIN PER ASTM-B-545 .000400 MIN THK OVER COPPER PER AMS2418 .000050 MIN THK.
- 11 FINISH: ZINC PLATE PER ASTM-B-633 .000200-.000400 THK WITH SUPPLEMENTARY CHROMATE (Cr3+).

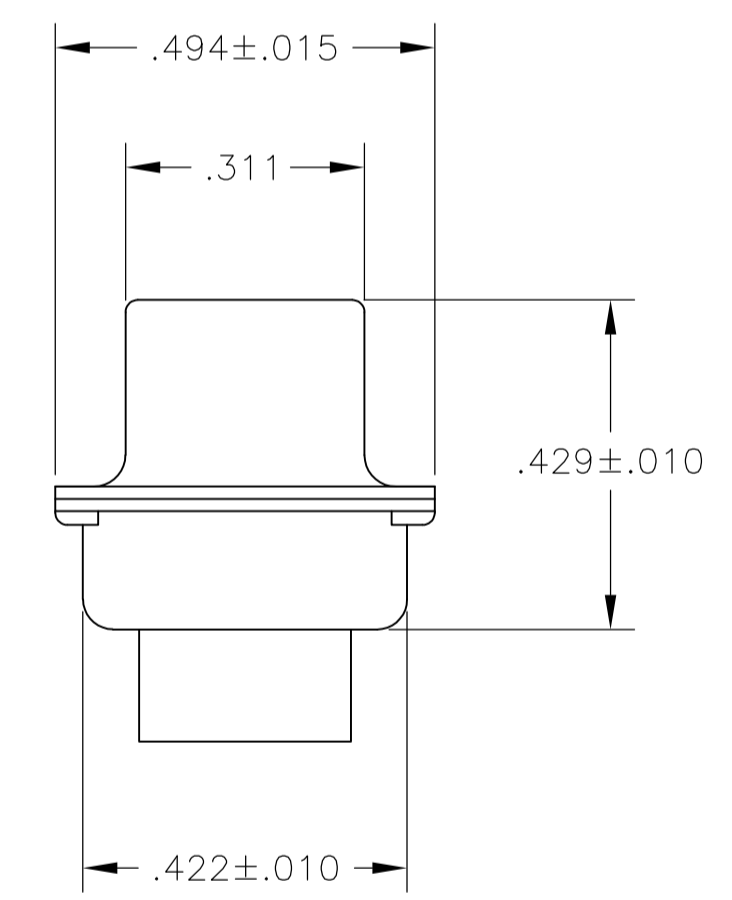
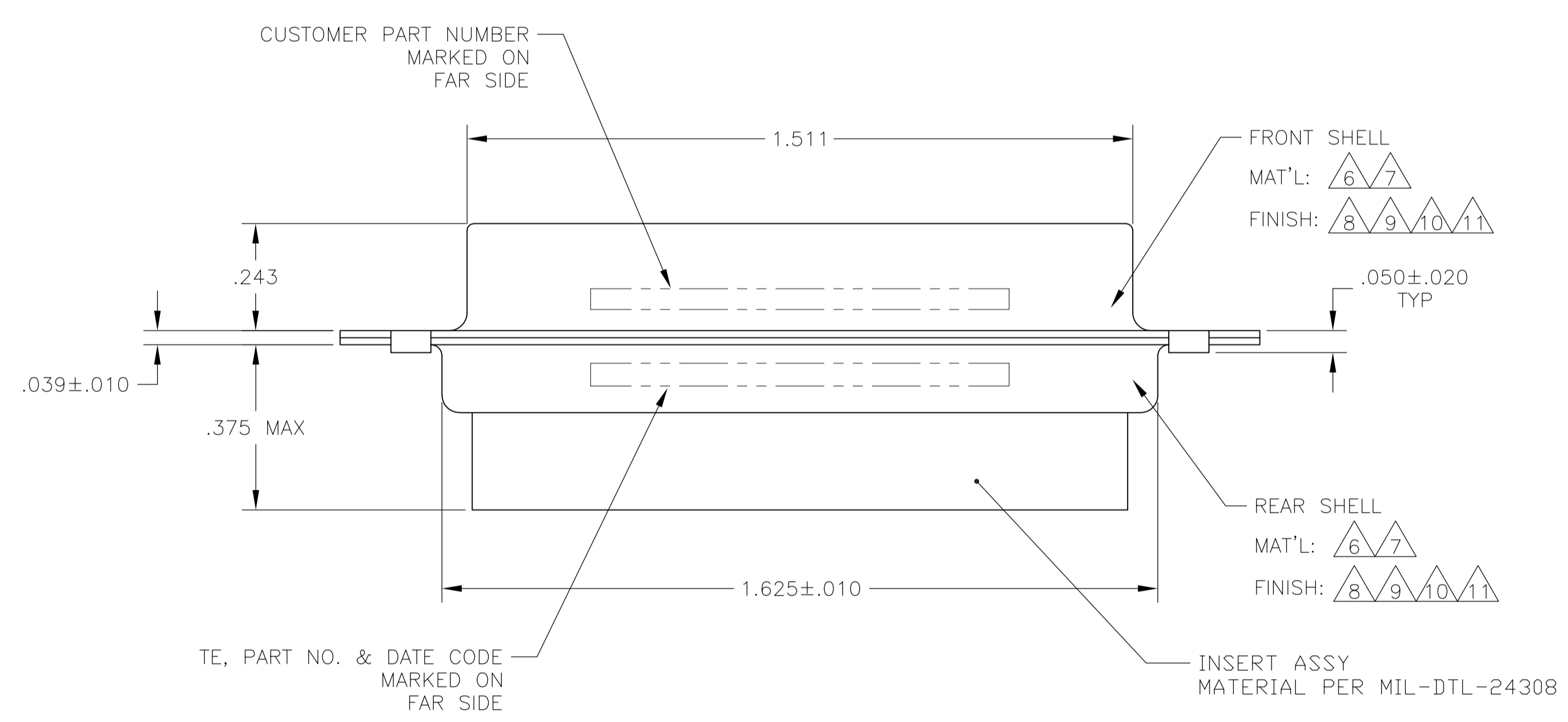

REMARKS	ϕA	CUSTOMER P/N	PART NO.
6 8	.120	T5935-0103-008	212502-7
6 10	.120	-	5-212502-5
6 11	.120	-	5-212502-1
7 9	.120	B010942-0018	212502-6
6 10	.120	-	212502-5
6 10	.154	-	212502-4
7 9	.154	311P405-11S-B-15	212502-3
7 9	.120	311P405-11S-B-12	212502-2
6 8	.120	-	212502-1

THIS DRAWING IS A CONTROLLED DOCUMENT.

APPROVED: A. EMADI, 29JAN88

DESIGNED: C.C. THOMAS, 27JAN88

DATE: 29JAN88

NAME: RECEPTACLE ASSEMBLY AMPLIMITE 9C4 SIZE 3, SERIES 109, COAX MIX

SIZE: A1, CAGE CODE: 00779, DRAWING NO: 212502

WEIGHT: -

CUSTOMER DRAWING

SCALE: 4:1, SHEET: 1 OF 1, REV: T

STE TE Connectivity