

REVISIONS					
P	LTR	DESCRIPTION	DATE	DMN	APVD
C3		REVISED PER ECR-16-010480	28OCT16	SC	DZ

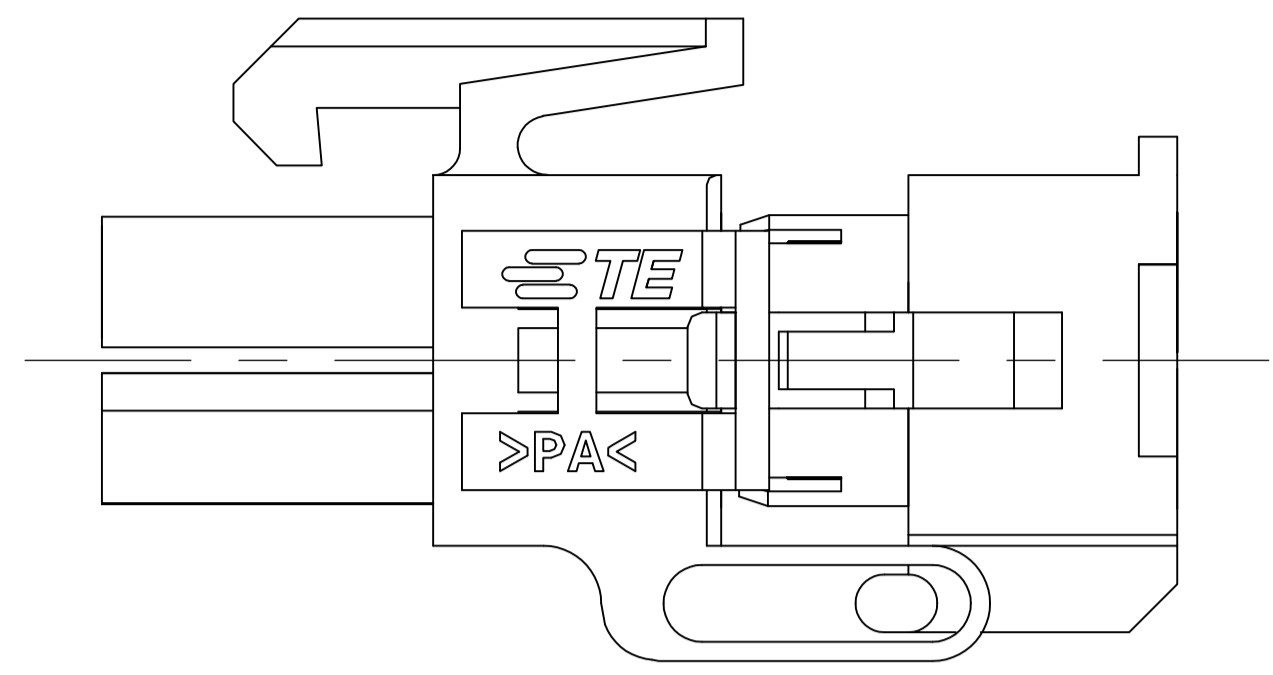

PRE-STAGED CONDITION

1 DIMENSIONS IN BRACKETS ARE IN INCHES.
 2 DIMENSION INDICATED IS AS MOLDED. ADDITIONAL GROWTH DUE TO SUBSEQUENT MOISTURE ABSORPTION MAY OCCUR.

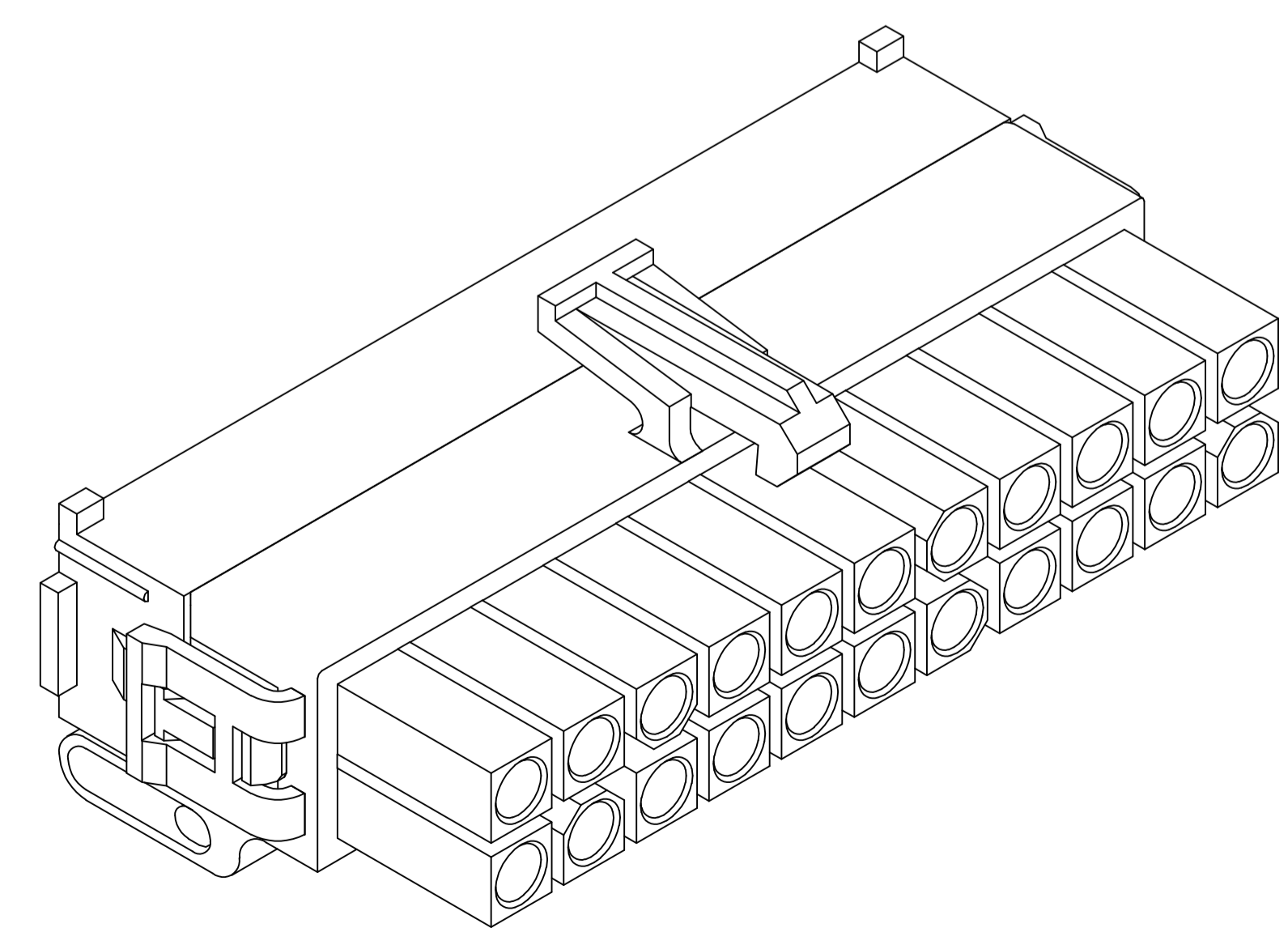
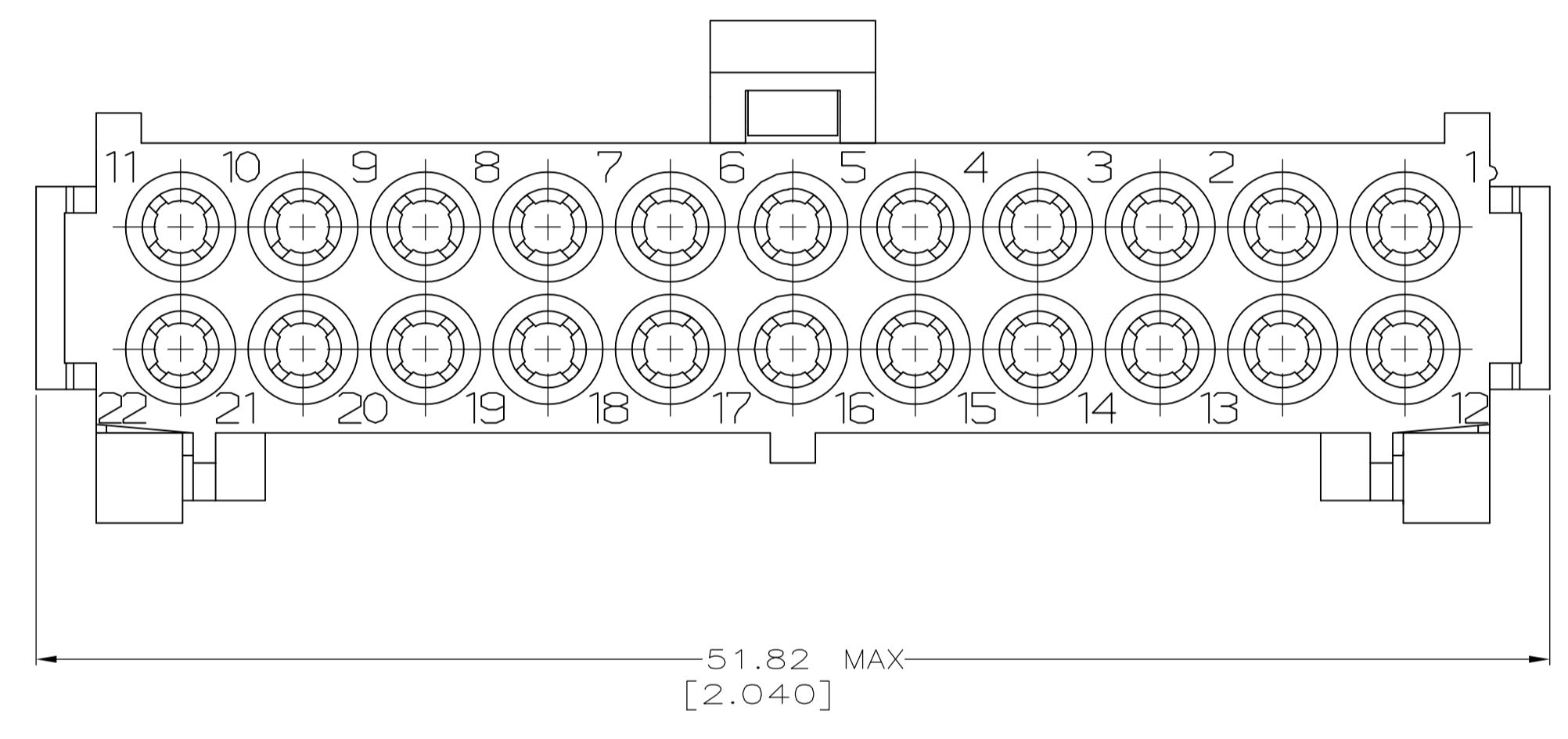
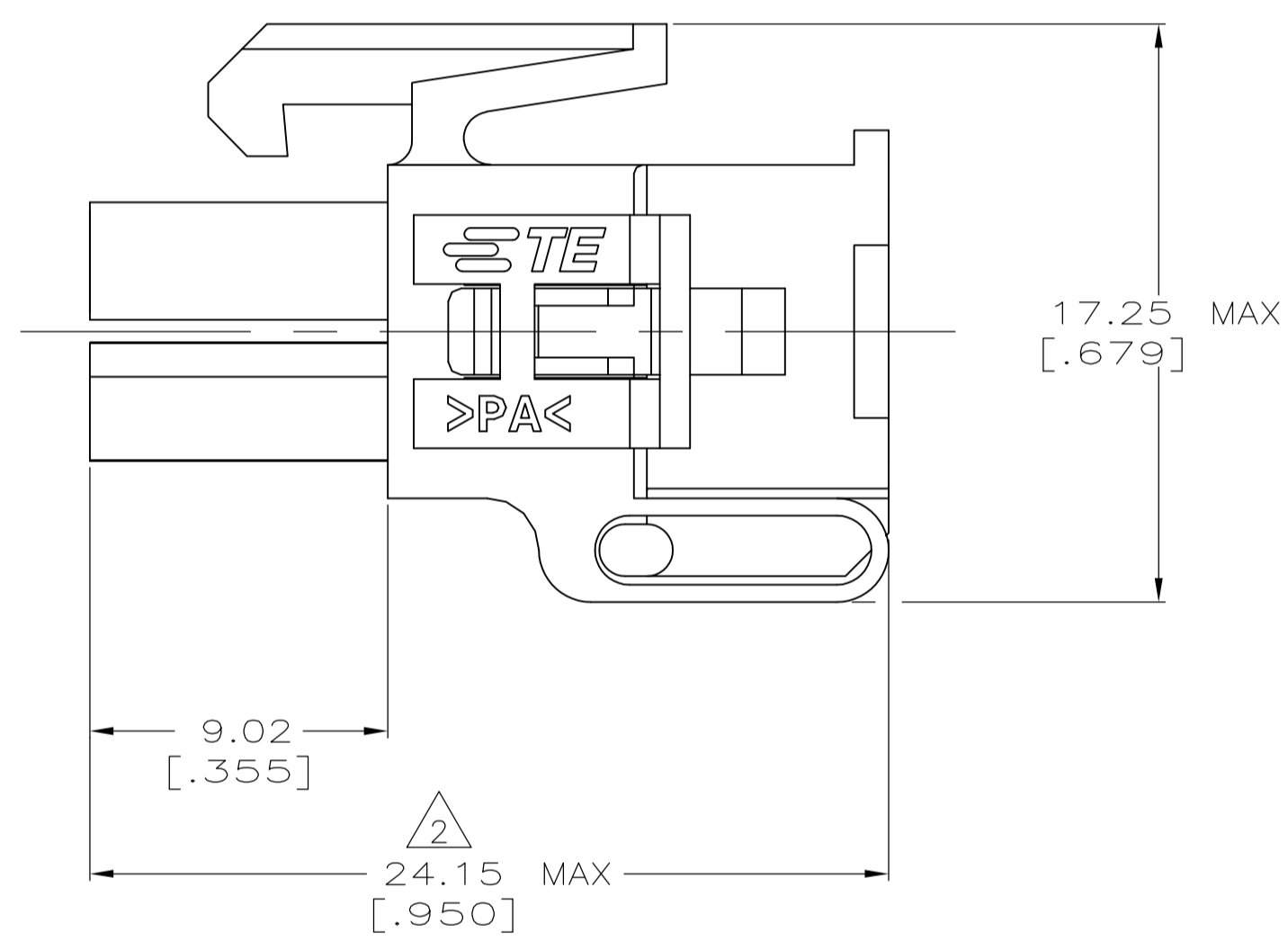
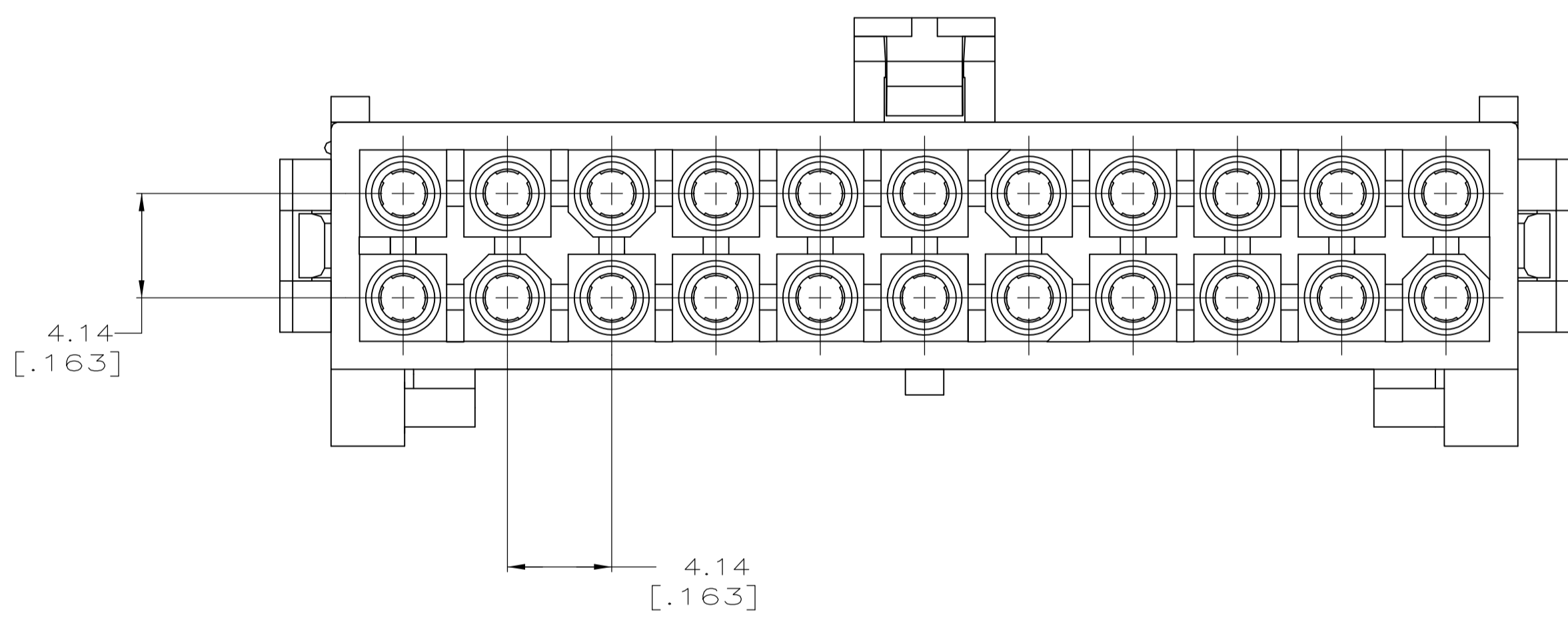

3-DIMENSIONAL MODEL NTS

794212-1
PART NUMBER

THIS DRAWING IS A CONTROLLED DOCUMENT.		DMN K. WHITAKER 5-20-97	TE Connectivity
DIMENSIONS: mm		CHK R. SWING 5-20-97	
TOLERANCES UNLESS OTHERWISE SPECIFIED:		APVD R. ORSTAD 5-20-97	NAME PLUG, 22 CIRCUIT, MINI UNIVERSAL MATE-N-LOK™ 2
0. PLC ± - 1. PLC ± - 2. PLC ± - 3. PLC ± 0.13 [.005] 4. PLC ± - ANGLES ± -		PRODUCT SPEC	APPLICATION SPEC
MATERIAL NYLON, UL94V-0, NATURAL		FINISH -	WEIGHT 0
CUSTOMER DRAWING		SIZE A1	CAGE CODE 00779
		SCALE 5:1	DRAWING NO. 794212
		SHEET 1 of 1	RESTRICTED TO REV C3