

4

3

2

1

REVISIONS			
LTR	DESCRIPTION	DATE	APPROVED
A	REVISED PER ECN# T-6209	3/24/86	J.B.
B	REDRAWN PER DCR# C040637	April/29/04	M.HIGGY

If this document is printed it becomes uncontrolled.  
Check for the latest revision.

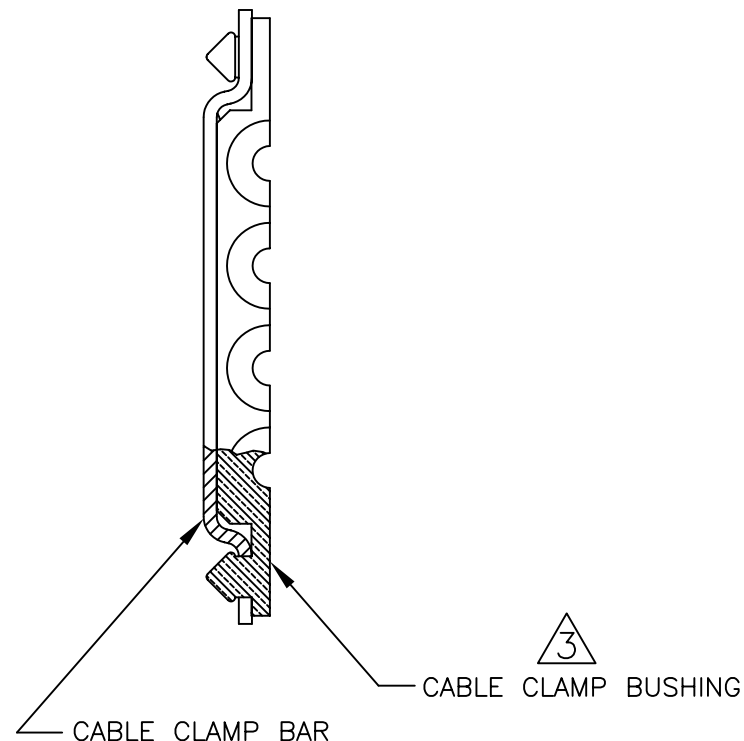
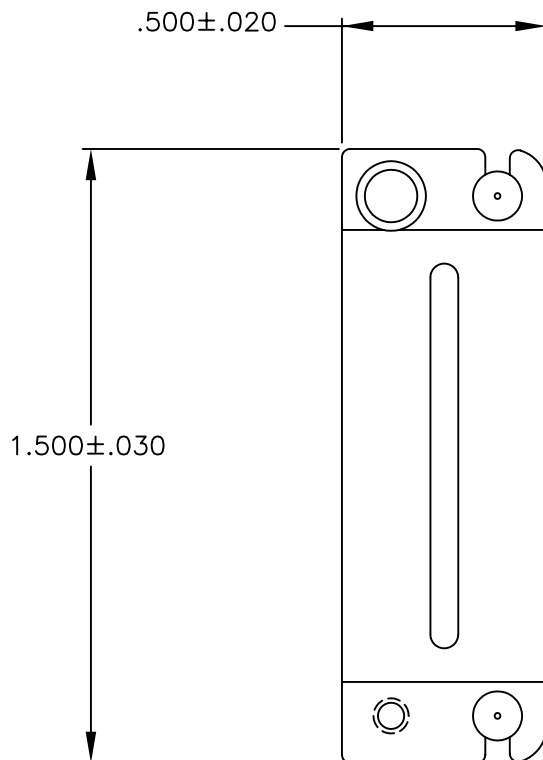

## NOTES:

1. CABLE CLAMP SUB-ASSY. USED ON CONNECTOR NUMBERS:

- a) MTCC1R-COAX01P-01
- b) MTCC1R-COAX01S-01
- c) MTCC1P-COAX01S-01
- d) MTCC1P-COAX01P-01
- e) D-659-003-03-003

2. TWO (2) CABLE CLAMP SUB-ASSEMBLIES REQUIRED FOR EACH CONNECTORS.

③ CABLE CLAMP BUSHING SUPPLIED ATTACHED TO CABLE CLAMP BAR AS SHOWN.

4. MATERIAL:

- a) CABLE CLAMP BAR STAINLESS STEEL PER ASTM A 240
- b) RUBBER, SILICONE A-A-59588

4. PLATING: CLAMP BAR CADMIUM PLATED PER SAE-AMS-QQ-P-416, OVER NICKEL UNDERPLATE.

## SPECIFICATION CONTROL DRAWING

© 2004 Tyco Electronics Corporation.  
All rights reserved

UNLESS OTHERWISE SPECIFIED DIMENSIONS ARE IN INCHES. METRIC DIMENSIONS ARE IN BRACKETS.	DRAWN ZS.ORBAN	DATE April/20/04		TYCO ELECTRONICS 300 Constitution Drive Menlo Park, CA. 94025 USA		
	CHECKED	DATE				
	DECIMALS .XXX ±.XXX [ mm] .XX ±.XX [ mm]	APPROVED M.HIGGY	DATE April/20/04	TITLE KIT, 1 INCH CABLE CLAMP CADMIUM PLATED MTCR SERIES		
	ANGLE ± X°	APPROVED	DATE			
WEIGHT .009 lbs.max. [ 4.02grms max.]	CAD NAME C040637.DWG		SIZE C	CAGE CODE: 06090	DWG. NO. D-659-0033-03-003	REV B
THIRD ANGLE PROJECTION			DO NOT SCALE THIS DRAWING   SCALE NONE   SHEET 1 OF 1			

DRAWING NO. D-659-0033-03-003 SHEET 1

4

3

2

1