

PN KEY ENGINEERING PN

E 4 6 2 X X X X X X X X X X X X

E - Packing without bag
W - Single Packing

Number of wires:
2 - 2 Wires + Earth

Cable type:
See Table

Head Colour:
G - Grey
N - Black
A - CSA-UL Black
B - CSA-UL Grey

Cable Length in[cm]
050 = 50cm
300 = 300cm
10K = 1000cm

Wiring Configuration:
See sheet 3

Voltage and Led Colour

Red Led:	Green Led:	Yellow Led:
1 = 12V	A = 12V	G = 12V
2 = 24V	B = 24V	H = 24V
3 = 48V	C = 48V	K = 48V
4 = 115V	D = 115V	L = 115V
5 = 230V	E = 230V	M = 230V

Earth PIN location (see insert orientation table):
2 = Earth on H12
6 = Earth on H6

Type of Gasket and Screw (see sheet 1):
1 = NBR Profile Gasket + Fixing Screw M3x25mm
2 = NBR Flat Gasket + Fixing Screw M3x25mm
3 = Silicone Profile Gasket + Fixing Screw M3x25mm
4 = Silicone Flat Gasket + Fixing Screw M3x25mm
P = NBR Integrated Gasket + Fixing Screw with Washer M3x27mm Assembled on Connector
R = NBR Integrated Gasket + Fixing Screw with Washer M3x27mm NOT Assembled on Connector
T = NBR Profile Gasket + Fixing Screw with Washer M3x27mm

CABLE TYPE	NO. OF WIRES	CROSS SECTION	CABLE O.D.	CABLE JACKET	UL	CSA	STATIC: TEMP. / BENDING RADIUS	DYNAMIC: TEMP. / BENDING RADIUS	SHIELD
A2	3	AWG 20	5.6mm±0.2	PVC BLACK	UL 2661	CSA C22.2	-30°C to +105°C, 10xO.D.	-5°C to +105°C, 15xO.D.	-
A3	3	AWG 18	6.5mm±0.25	PVC BLACK	UL 2661	CSA C22.2	-30°C to +105°C, 10xO.D.	-5°C to +105°C, 15xO.D.	-
B2	3	AWG 20	5.6mm±0.2	PUR BLACK	UL 20668	CSA C22.2	-40°C to +90°C, 5xO.D.	-25°C to +90°C, 10xO.D.	-
B3	3	AWG 18	6.5mm±0.2	PUR BLACK	UL 20668	CSA C22.2	-40°C to +90°C, 5xO.D.	-25°C to +90°C, 10xO.D.	-
F4	3	1mm ²	7.1mm+0.2	PVC GREY	-	-	-15°C to +70°C, 10xO.D.	-5°C to +60°C, 15xO.D.	-
I0	3	1mm ²	7.6mm±0.2	PVC GREY	-	-	-25°C to +70°C, 10xO.D.	-5°C to +70°C, 15xO.D.	YES
I2	3	0.5mm ²	5.5mm+0.3	PVC GREY	-	-	-25°C to +70°C, 10xO.D.	-5°C to +70°C, 15xO.D.	-
I3	3	0.75mm ²	6.0mm±0.2	PVC GREY	-	-	-25°C to +70°C, 10xO.D.	-5°C to +70°C, 15xO.D.	-
I4	3	1mm ²	7.1mm+0.2	PVC GREY	-	-	-25°C to +70°C, 10xO.D.	-5°C to +70°C, 15xO.D.	-
N2	3	0.5mm ²	5.6mm±0.7	PVC BLACK	-	-	-20°C to +70°C, 3xO.D.	-15°C to +70°C, 5xO.D.	-
N3	3	0.75mm ²	6.8mm±0.8	PVC BLACK	-	-	-20°C to +70°C, 3xO.D.	-15°C to +70°C, 5xO.D.	-
N4	3	1mm ²	7.15mm±0.85	PVC BLACK	-	-	-20°C to +70°C, 3xO.D.	-15°C to +70°C, 5xO.D.	-
P1	3	0.34mm ²	5.3mm±0.2	PUR BLACK	-	-	-25°C to +80°C, 10xO.D.	-5°C to +80°C, 15xO.D.	-
P2	3	0.5mm ²	5.5mm+0.3	PUR BLACK	-	-	-40°C to +90°C, 7.5xO.D.	-15°C to +90°C, 12.5xO.D.	-
P3	3	0.75mm ²	6.5mm±0.2	PUR BLACK	-	-	-40°C to +90°C, 7.5xO.D.	-15°C to +90°C, 12.5xO.D.	-

Notes:

- Please see excel sheet 1210501000_PDP for currently configured part numbers.
- Drawing is a replacement for: SD-121050-003

SYMBOLS	THIS DRAWING CONTAINS INFORMATION THAT IS PROPRIETARY TO MOLEX ELECTRONIC TECHNOLOGIES, LLC AND SHOULD NOT BE USED WITHOUT WRITTEN PERMISSION		CURRENT REV DESC:		molex		
	DIMENSION UNITS	SCALE	EC NO: 603741				
	mm	1:1	DRWN: APAWLAK01 2018/07/16		STANDARD E462 DIN FORM INDUSTRIAL		
	GENERAL TOLERANCES (UNLESS SPECIFIED)		CHK'D: RSILLER 2018/08/31		PRODUCT CUSTOMER DRAWING		
ANGULAR TOL	±	APPR: RSILLER 2018/08/31		DOCUMENT NUMBER			
4 PLACES	±	INITIAL REVISION:		1210501000			
3 PLACES	±	DRWN: APAWLAK01 2018/07/16		DOC TYPE			
2 PLACES	± 0.05	APPR: RSILLER 2018/08/31		PSD			
1 PLACE	± 0.1	MATERIAL NUMBER		DOC PART			
0 PLACES	±	SEE 1210501000_PDP		000			
DRAFT WHERE APPLICABLE MUST REMAIN WITHIN DIMENSIONS		THIRD ANGLE PROJECTION	DRAWING	SERIES	CUSTOMER	REVISION	
			A3-SIZE	121050	GENERAL MARKET	A	
				SHEET NUMBER		2 OF 3	

WIRING DIAGRAMS

ELECTRICAL DIAGRAM 00

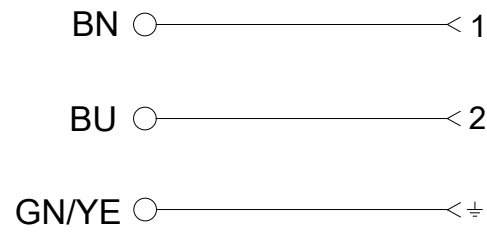

ELECTRICAL DIAGRAM A1

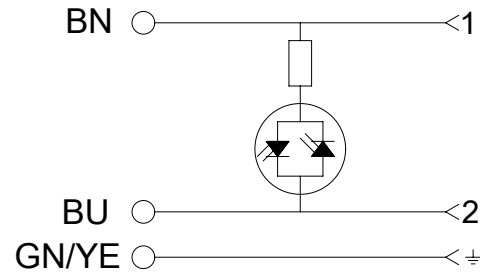

ELECTRICAL DIAGRAM C3

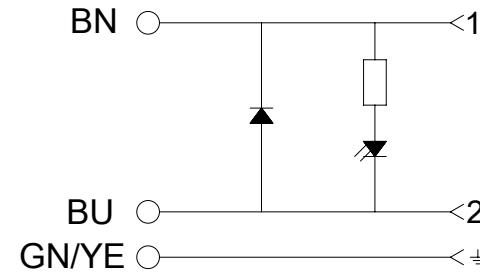

ELECTRICAL DIAGRAM C4

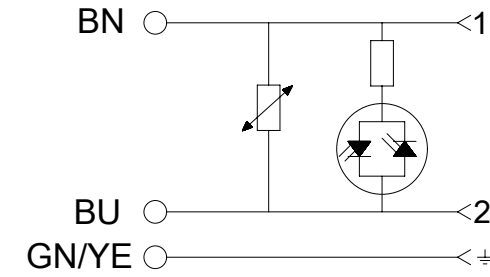

ELECTRICAL DIAGRAM E0

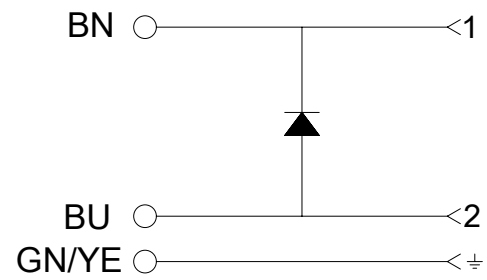

ELECTRICAL DIAGRAM S0

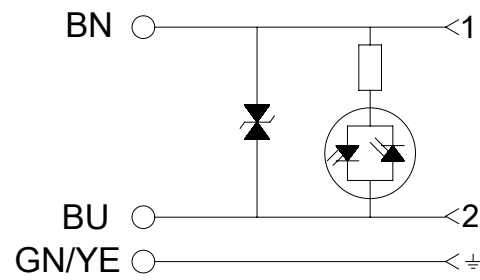

ELECTRICAL DIAGRAM S1

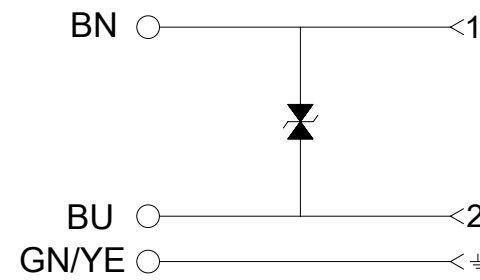

ELECTRICAL DIAGRAM NS

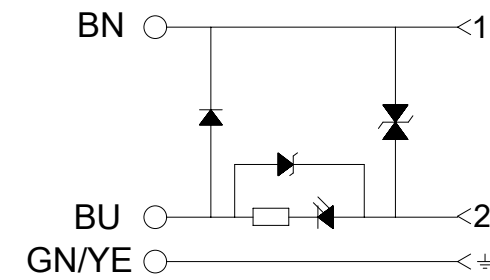

Technical Spec:

Supply Voltage: See PN KEY

Max. current: 5A; A1-C4-S0
1,5A; R2

Contact Resistance: ≤15milliohms max.

Operating Temperature:
with NBR Gasket: -40°C +90°C
with Silicone: -40°C +125°C

THIS DRAWING CONTAINS INFORMATION THAT IS PROPRIETARY TO MOLEX ELECTRONIC TECHNOLOGIES, LLC AND SHOULD NOT BE USED WITHOUT WRITTEN PERMISSION									
SYMBOLS	DIMENSION UNITS	SCALE	CURRENT REV DESC:				molex		
	mm	1:1							
▽ = 0	GENERAL TOLERANCES (UNLESS SPECIFIED)		EC NO: 603741				STANDARD E462 DIN FORM INDUSTRIAL		
▽ = 0			DRWN: APAWLAK01 2018/07/16						
▽ = 0	ANGULAR TOL ± °		CHK'D: RSILLER 2018/08/31				PRODUCT CUSTOMER DRAWING		
▽ = 0			APPR: RSILLER 2018/08/31						
▽ = 0	4 PLACES ±		INITIAL REVISION:				DOCUMENT NUMBER		
▽ = 0	3 PLACES ±		DRWN: APAWLAK01 2018/07/16						
▽ = 0	2 PLACES ± 0.05		APPR: RSILLER 2018/08/31				DOC TYPE DOC PART REVISION		
▽ = 0	1 PLACE ± 0.1								
▽ = 0	0 PLACES ±						MATERIAL NUMBER CUSTOMER SHEET NUMBER		
☒ = 0	DRAFT WHERE APPLICABLE MUST REMAIN WITHIN DIMENSIONS		THIRD ANGLE PROJECTION	DRAWING	SERIES	121050			
▽ = 0				A3-SIZE					

DOCUMENT STATUS	P1	RELEASE DATE	2018/08/31	12:24:52
-----------------	----	--------------	------------	----------

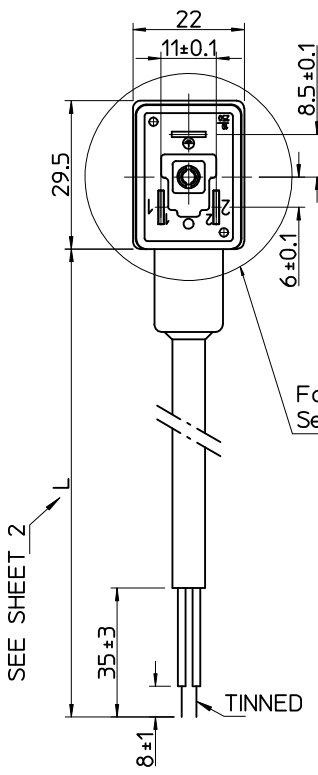

Screw and gasket, see sheet 2, PN Key
Face View
See Insert Orientation

CIRCUIT PRINTOUT/WHITE

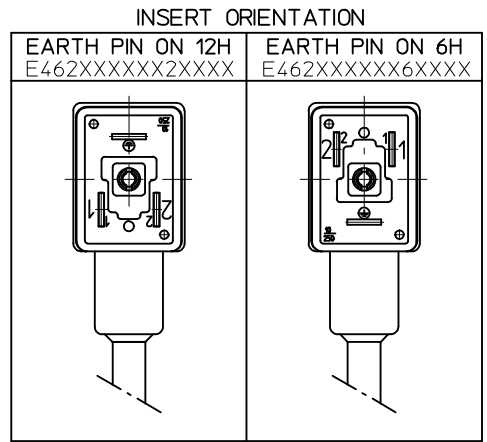
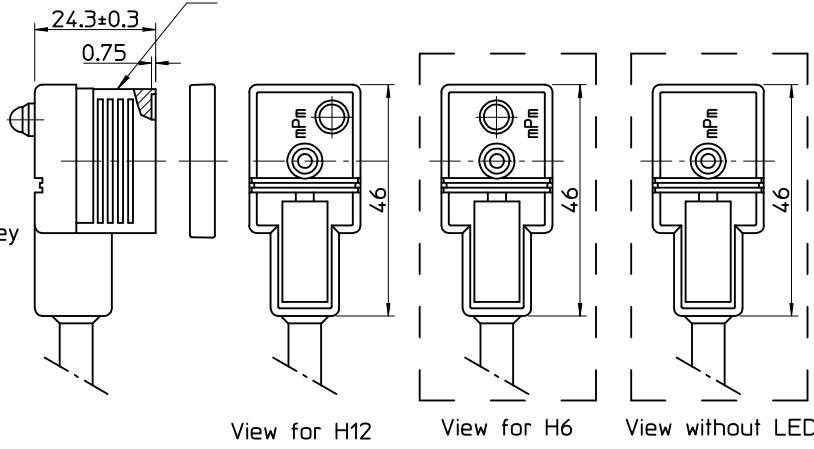
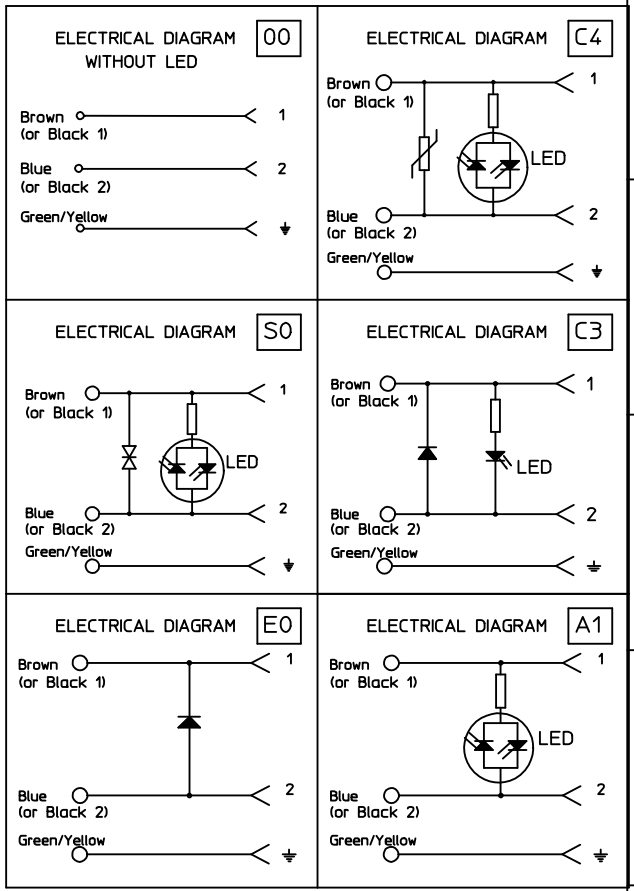

Table of length tolerances [mm]

Over	Up to and including	Tolerance (+)
0	1000	±20
1000	3000	±30
3000	5000	±40
5000	10000	±50
10000	15000	±100
15000	20000	±150
20000		±L/100



<p>DRAWING UPDATED EC NO: IPG2013-1493 DRW:NDYSZEWSKA 2013/03/27 CHKD: JMARSZALEK 2013/03/27 APPR: MIWASIECZKO 2013/03/28</p>	<p>QUALITY SYMBOLS ▽ ±0 ◻ ±0</p>	<p>GENERAL TOLERANCES (UNLESS SPECIFIED)</p> <table border="1"> <thead> <tr> <th></th> <th>mm</th> <th>INCH</th> </tr> </thead> <tbody> <tr> <td>4 PLACES</td> <td>±---</td> <td>±---</td> </tr> <tr> <td>3 PLACES</td> <td>±---</td> <td>±---</td> </tr> <tr> <td>2 PLACES</td> <td>±---</td> <td>±---</td> </tr> <tr> <td>1 PLACE</td> <td>±---</td> <td>±---</td> </tr> <tr> <td>0 PLACE</td> <td>±---</td> <td>±---</td> </tr> </tbody> </table>			mm	INCH	4 PLACES	±---	±---	3 PLACES	±---	±---	2 PLACES	±---	±---	1 PLACE	±---	±---	0 PLACE	±---	±---	<p>DIMENSION STYLE MM ONLY</p>	<p>SCALE</p>	<p>DESIGN UNITS METRIC</p>	<p>FIRST ANGLE PROJECTION</p>
			mm	INCH																					
4 PLACES	±---	±---																							
3 PLACES	±---	±---																							
2 PLACES	±---	±---																							
1 PLACE	±---	±---																							
0 PLACE	±---	±---																							
<p>DRAFT WHERE APPLICABLE MUST REMAIN WITHIN DIMENSIONS</p>	<p>ANGULAR ±---°</p>	<p>MATERIAL NO.</p>	<p>TITLE</p>	<p>DOCUMENT NO.</p>	<p>SHEET NO.</p>																				

E462XXXXXXXXXX
FORM INDUSTRIAL

molex

SD-121050-003

1 OF 4

THIS DRAWING CONTAINS INFORMATION THAT IS PROPRIETARY TO MOLEX INCORPORATED AND SHOULD NOT BE USED WITHOUT WRITTEN PERMISSION

10 9 8 7 6 5 4 3 2 1

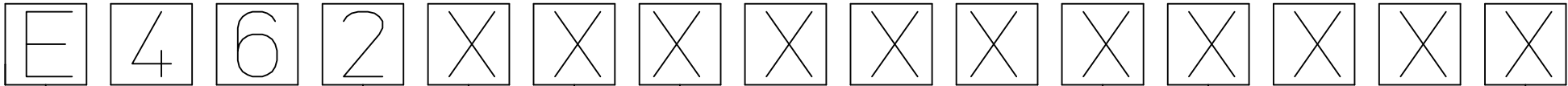

E - Packing without bags
W - Single packing
Q - Quick packing

NUMBER OF WIRES:
1=2 WIRES
2=2 WIRES + EARTH

CABLE TYPE
SEE TABLE 1

CABLE CROSS SECTION AREA
SEE TABLE 2

HEAD COLOUR:
G=GREY;
N=BLACK;
T=TRANSPARENT;
A=CSA-UL BLACK;
B=CSA-UL GREY.

CABLE LENGHT IN CM
Eg.:050=50 CM, 300=300 CM, 10K=1000 CM.

EARTH PIN LOCATION:
2=EARTH ON 12H,
6=EARTH ON 6H.

GASKET SCREWS:

- 1=NBR PROFILE GASKET+FIXING SCREWS (M3x25 mm).
- 2=NBR FLAT GASKET+SCREW (M3x25 mm).
- 3=SILICONE PROFILE GASKET+SCREW (M3x25 mm).
- 4=SILICON FLAT GASKET+SCREW (M3x25 mm).
- P=INTEGRATED GASKET+FIXING SCREW+GROMMET (M3x27 mm).
- R=INTAGRATED GASKET+SCREW+GROMMET (M3x27 mm).
- T=PROFILE GASKET+SCREW+GROMMET (M3x27 mm).

INTERNAL CIRCUIT WIREING CONFIGURATION

VOLTAGE AND LED COLOUR:

1= 12V	A= 12V	G= 12V
2= 24V	B= 24V	H= 24V
3= 48V	C= 48V	K= 48V
4= 115V	D= 115V	L= 115V
5= 230V	E= 230V	M= 230V

RED LED GREEN LED YELLOW LED

F

E

D

C

B

A

F

E

D

C

B

A

DRAWING UPDATED EC NO: IPG2013-1493 DRWING: MYSZEWSKA 2013/03/27 CHKD: JMARSZALEK 2013/03/27 APPR: MIWASIECZKO 2013/03/28	QUALITY SYMBOLS 	GENERAL TOLERANCES (UNLESS SPECIFIED)		DIMENSION STYLE MM ONLY	SCALE 1:1	DESIGN UNITS METRIC	FIRST ANGLE PROJECTION			
			mm	INCH	DRAWN BY JMARSZALEK	DATE 2012/10/31	TITLE E462XXXXXXXXXX FORM INDUSTRIAL			
		4 PLACES	± ---	± ---	CHECKED BY MSZWAJKOWSKI	DATE 2012/10/31				
		3 PLACES	± ---	± ---	APPROVED BY MIWASIECZKO	DATE 2012/11/09				
		2 PLACES	± ---	± ---	MATERIAL NO.	DOCUMENT NO.				
2 PLACES	± ---	± ---	DRAFT WHERE APPLICABLE MUST REMAIN WITHIN DIMENSIONS		SIZE A3		THIS DRAWING CONTAINS INFORMATION THAT IS PROPRIETARY TO MOLEX INCORPORATED AND SHOULD NOT BE USED WITHOUT WRITTEN PERMISSION			
1 PLACE	± ---	± ---					SHEET NO. 2 OF 4			
0 PLACE	± ---	± ---								

9 8 7 6 5 4 3 2 1

TABLE 2 - CABLES

Molex PN	mPm	Code	Wires	Cross Section	Material	Color	Diameter Ø	DIN A-B	DIN C
1210180080	I	0	3	1 mm2	PVC CEI 2022 II O.R.	Grey RAL7035	-	-	-
1210180467	A	2	2	20 AWG	PVC CSA/UL 2661	Black	5,5+/-0,2 mm	OK.	OK.
-	A	2	3	20 AWG	PVC CSA/UL 2661	Black	5,6+/-0,2 mm	OK.	OK.
1210180394	A	2	4	20 AWG	PVC CSA/UL 2661	Black	6,2+/-0,2 mm	OK.	OK.
-	A	2	5	20 AWG	PVC CSA/UL 2661	Black	7+/-0,2 mm	OK.	-
1210180297	B	2	2	20 AWG	PUR CSA/UL 20668	Black	5,5+/-0,2 mm	OK.	OK.
1210180126	B	2	3	20 AWG	PUR CSA/UL 20668	Black	5,6+/-0,2 mm	OK.	OK.
1210180367	B	2	4	20 AWG	PUR CSA/UL 20668	Black	6,2+/-0,2 mm	OK.	OK.
-	B	2	5	20 AWG	PUR CSA/UL 20668	Black	7+/-0,2 mm	OK.	-
1210180122	D	2	3	0,5 mm2	PVC T12 CEI 20-20	Grey	-	-	-
-	F	2	3	0,5 mm2	CNOMO	Grey RAL7000	5,5+/-0,2 mm	OK.	OK.
1210180047	I	2	2	0,5 mm2	PVC CEI 2022 II O.R.	Grey RAL7035	5,5+/-0,2 mm	OK.	OK.
-	I	2	3	0,5 mm2	PVC CEI 2022 II O.R.	Grey RAL7035	5,5+/-0,2 mm	OK.	OK.
1210180146	I	2	4	0,5 mm2	PVC CEI 2022 II O.R.	Grey RAL7035	6,5+/-0,2 mm	OK.	-
1210180177	I	2	5	0,5 mm2	PVC CEI 2022 II O.R.	Grey RAL7035	7+/-0,2 mm	OK.	-
1210180022	N	2	2	0,5 mm2	PVCH03	Black	5,1+ 0,2-0 mm	OK.	OK.
1210180064	N	2	3	0,5 mm2	PVCH03	Black	5,4+ 0,2-0 mm	OK.	OK.
1210180153	N	2	4	0,5 mm2	PVCH03	Black	5,75+0,2-0 mm	OK.	OK.
1210180046	P	2	2	0,5 mm2	PUR - BLEND	Black	5,5+/-0,2 mm	OK.	OK.
-	P	2	3	0,5 mm2	PUR - BLEND	Black	5,5+/-0,2 mm	OK.	OK.
1210180302	P	2	4	0,5 mm2	PUR - BLEND	Black	-	-	-
-	P	2	5	0,5 mm2	PUR - BLEND	Black	7+/-0,2 mm	OK.	OK.
1210180409	A	3	2	18 AWG	PVC CSA/UL 2661	Black	6,5+/-0,2 mm	OK.	-
1210180129	A	3	3	18 AWG	PVC CSA/UL 2661	Black	6,5+/-0,2 mm	OK.	-
1210180169	A	3	4	18 AWG	PVC CSA/UL 2661	Black	7+/-0,2 mm	OK.	-
-	A	3	5	18 AWG	PVC CSA/UL 2661	Black	7,8+/-0,2 mm	OK.	-
1210180351	B	3	2	18 AWG	PUR CSA/UL 20668	Black	6,5+/-0,2 mm	OK.	-
1210180127	B	3	3	18 AWG	PUR CSA/UL 20668	Black	6,5+/-0,2 mm	OK.	-
1210180127	B	3	4	18 AWG	PUR CSA/UL 20668	Black	7+/-0,2 mm	OK.	-
-	B	3	5	18 AWG	PUR CSA/UL 20668	Black	7,8+/-0,2 mm	OK.	-
1210180073	D	3	3	0,75 mm2	PVC T12 CEI 20-20	Grey	-	-	-
1210180145	D	3	4	0,75 mm2	PVC T12 CEI 20-20	Grey	-	-	-
1210180120	I	3	3	0,75 mm2	PVC CEI 2022 II O.R.	Grey RAL7035	-	-	-
1210180143	I	3	4	0,75 mm2	PVC CEI 2022 II O.R.	Grey RAL7035	-	-	-
1210180032	N	3	2	0,75 mm2	PVCH05	Black	6,2+ 0,2-0 mm	OK.	-
1210180069	N	3	3	0,75 mm2	PVCH05	Black	6,6+0,2-0 mm	OK.	-
-	N	3	4	0,75 mm2	PVCH05	Black	7,15+0,2-0 mm	OK.	-
1210180174	N	3	5	0,75 mm2	PVCH05	Black	8,0+0,2-0 mm	OK.	-
-	P	3	2	0,75 mm2	PUR - BLEND	Black	6,5+/-0,2 mm	OK.	-

TABLE 2 - CABLES

Molex PN	mPm	Code	Wires	Cross Section	Material	Color	Diameter Ø	DIN A-B	DIN C
1210180071	P	3	3	0,75 mm2	PUR - BLEND	Black	6,5+/-0,2 mm	OK.	-
1210180152	P	3	4	0,75 mm2	PUR - BLEND	Black	7+/-0,2 mm	OK.	-
1210180384	R	3	3	0,75 mm2	TPR HAL. FREE	Black	6,5+/-0,2 mm	OK.	-
1210180094	T	3	3	0,75 mm2	PUR CSA/UL	Yellow	-	-	-
1210180309	Y	3	3	0,75 mm2	SIL/0300	Red	6,5+/-0,2 mm	-	-
1210180081	F	4	3	1 mm2	CNOMO	Grey RAL7000	-	-	-
-	F	4	4	1 mm2	CNOMO	Grey RAL7000	7,1+0,2-0 mm	OK.	-
1210180042	I	4	2	1 mm2	PVC CEI 2022 II O.R.	Grey RAL7035	7,1+0,2-0 mm	OK.	-
1210180079	I	4	3	1 mm2	PVC CEI 2022 II O.R.	Grey RAL7035	7,1+0,2-0 mm	OK.	-
1210180036	N	4	2	1 mm2	PVCH05	Black	6,5+0,2-0 mm	OK.	-
1210180082	N	4	3	1 mm2	PVCH05	Black	6,9+0,2-0 mm	OK.	-
1210180117	R	4	3	1 mm2	TPR HAL. FREE	Black	-	-	-
1210180085	N	5	3	1,5 mm2	PVCH05	Black	8,3+0,2-0 mm	OK.	-
1210180313	I	6	2	0,35 mm2	PVC CEI 2022 II O.R.	Grey RAL7035	-	-	-
-	A	7	3	20 AWG	PVC CSA/UL 2661	Yellow	5,6+/-0,2 mm	OK.	OK.
1210180149	I	9	4	0,75 mm2	PVC CEI 2022 II O.R.	Grey RAL7035	-	-	-

TABLE 1 - CABLES TYPE

Code	Cable types	Features	Stranding
N	PVC	Application general purpose cable which has good resistance to water, but usually poor oil resistance.	0,5 mm2 = 15 x 0,20 0,75 mm2 = 21 x 0,20 1 mm2 = 28 x 0,20
I	CEI	Approved to IEC 332-2A, flame retardant and self extinguishing. Limited resistant to mineral oils.	0,5 mm2 = 28 x 0,15 0,75 mm2 = 42 x 0,15 1 mm2 = 32 x 0,20
P	PUR	Offer good resistance to oil and chemicals. Can swell when constantly immersed in water.	0,5 mm2 = 28 x 0,15 0,75 mm2 = 42 x 0,15 1 mm2 = 32 x 0,20
A	PVC CSA-UL	Approved to CSA-UL 2661, application general purpose cable which has good resistance to water, but usually poor oil resistance.	20 AWG = 32 x 0,15 18 AWG = 52 x 0,15
B	PUR CSA-UL	Approved to CSA-UL 20668, very good resistance to oil and chemicals.	20 AWG = 32 x 0,15 18 AWG = 52 x 0,15

DRAWING UPDATED EC NO: IPG2013-1493 DRWING: MYSZEWKA 2013/03/27 CHKD: JMARSZALEK 2013/03/27 APPR: MIWASIECZKO 2013/03/28	QUALITY SYMBOLS ▽=0 ◻=0	GENERAL TOLERANCES (UNLESS SPECIFIED)		DIMENSION STYLE MM ONLY		SCALE 1:1	DESIGN UNITS METRIC	FIRST ANGLE PROJECTION	
			mm	INCH	DRAWN BY JMARSZALEK	DATE 2012/10/31	TITLE E462XXXXXXXXXX FORM INDUSTRIAL		
		4 PLACES	± ---	± ---	CHECKED BY MSZWAJKOWSKI	DATE 2012/10/31			
		3 PLACES	± ---	± ---	APPROVED BY MIWASIECZKO	DATE 2012/11/09			
2 PLACES	± ---	± ---	ANGULAR ± --- °		DOCUMENT NO. SD-121050-003		SHEET NO. 3 OF 4		
1 PLACE	± ---	± ---	DRAFT WHERE APPLICABLE MUST REMAIN WITHIN DIMENSIONS		THIS DRAWING CONTAINS INFORMATION THAT IS PROPRIETARY TO MOLEX INCORPORATED AND SHOULD NOT BE USED WITHOUT WRITTEN PERMISSION				
0 PLACE	± ---	± ---							

