

AFBR-4526Z, AFBR-452BZ

Plastic Optical Fiber Duplex Connector for AFBR-5972xZ



Description

The Broadcom[®] AFBR-452xZ duplex connectors are designed for use with the Broadcom fast Ethernet transceiver AFBR- 5972xZ. The rugged design contains a latching mechanism for an increased retention force. The simple snap-together concept saves the user labor and tool cost.

The connectors are made of a rugged, flame retardant plastic, which is good for industrial and other harsh environments. The AFBR-452xZ duplex connectors are for use with plastic optical fiber (POF) only.

For termination of POF with AFBR-452xZ, use the polishing kit AFBR-4594Z.

Features

- ULTEM plastic material (UL File #E121562)
- Available in two colors: black and blue
- Suitable for 1-mm diameter duplex plastic optical fiber (POF)
- Latching mechanism for increased retention force
- Easy installation of POF links with AFBR-5972xZ

Applications

- Industrial data links for factory automation and plant control
- Intra-system links, board-to-board, rack-to-rack
- Medical instruments
- High voltage isolation

Absolute Maximum Ratings

Parameter	Min.	Max.	Unit	Note
Storage and Operating Temperature	-40	85	°C	a
Recommended Operation Temperature	-40	85	°C	a
Installation Temperature	0	70	°C	a

- a. Storage and operating temperatures refer to the ranges over which the connectors can be used when not subjected to mechanical stress. Installation temperature refers to the ranges over which connectors may be installed onto the fiber and over which connectors can be connected and disconnected from the transceiver.

Mechanical Characteristics

Parameter	Min.	Typ.	Max.	Unit	Temp. [°C]	Note
Retention Force, Connector to Transceiver, Latching Button Pressed	15	20	—	N	25	a
Retention Force, Connector to Transceiver, Latching Button NOT Pressed	—	24	—	N	25	a, b
	8	—	—	N	-40 to +85	
Tensile Force, Connector to Cable	—	90	—	N	—	b
Insertion Force, Connector to Transceiver	—	20	—	N	—	b

- a. Typical data at 25°C.
 b. **CAUTION!** The latching mechanism release button should be pressed before attempting to disconnect the fiber. If the connector is pulled out of the transceiver without pressing the lever, damage will occur.

Termination Guide for AFBR-452xZ

Step-by-Step Plastic Cable Connecting Instructions

The following step-by-step guide describes how to terminate plastic fiber optic cable. It is ideal for both field and factory installations. Connectors can be easily installed on cable ends with standard tools such as wire strippers and cutters.

Finishing the cable is accomplished with the Broadcom AFBR-4594Z Polishing Kit, consisting of a three hole polishing fixture, 600 grit abrasive paper, and 3- μ m pink lapping film. The connector can be used immediately after polishing.

The following materials are needed for plastic fiber termination:

1. Plastic optical fiber cable (Example: HFBR-EUD500Z)
2. Wire cutters or scissors
3. 16-gauge wire stripper (Example: Ideal Stripmaster type 45-092)
4. AFBR-4594Z polishing kit
5. Duplex connectors AFBR-452xZ

Step 1: Stripping the Fiber

The zip cord structure of the duplex cable permits easy separation of the channels. The channels should be separated a minimum of 100 mm (4 in) to a maximum of 150 mm (6 in.) back from the ends to permit connecting, polishing, and cable end flexibility.

After cutting the cable to the desired length, strip off approximately 7 mm (0.3 in) of the outer jacket with the 16-gauge wire strippers.

The separated duplex cable should be stripped to roughly equal lengths on each cable end.

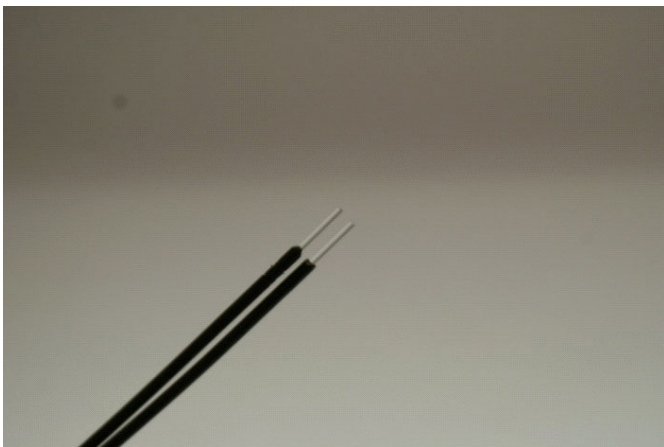

Step 2: Putting on the Connector

Place the connector on each end of the fiber, and slide the connector down until the fiber jacket stops it. The fiber should protrude no less than 1.5 mm (0.06 in.) from the end of the connector.

Manually press connectors together. The connectors are secured when top halves latch into the ferrule halves.

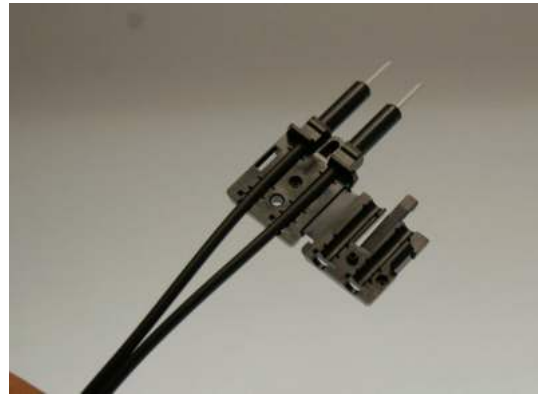

During insertion of the fiber into the connector, make sure that the orientation of the connector is correct (see next figure). Make sure that the optical channels are connected correctly (Tx1 → Rx2; Tx2 → Rx1).

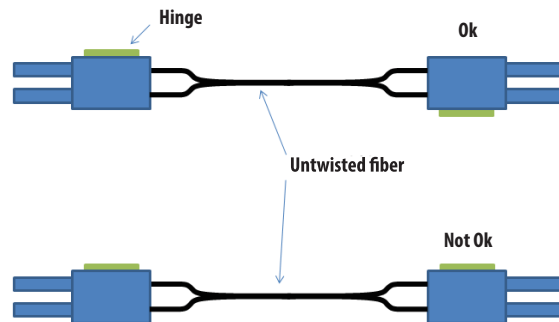

Step 3: Trimming and Polishing

Any fiber in excess of 1.5 mm (0.06 in.) protruding from the connector end should be cut off with wire cutters or scissors.

Insert the connector fully into the polishing fixture with the trimmed fiber protruding from the bottom of the fixture. This plastic polishing fixture can be used to polish one or two simplex connectors or one duplex connector.

NOTE: The four dots on the bottom of the polishing fixture are wear indicators. Replace the polishing fixture when any dot is no longer visible.

Press the polishing tool down on the 600 grit abrasive paper. Polish the fiber using a figure-eight pattern until the connector is flush with the bottom of the polishing fixture. Wipe the connector and fixture with a clean cloth or tissue.

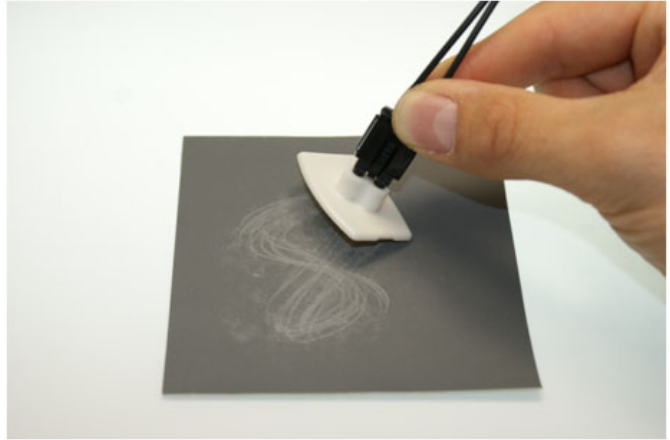

Step 4: Finishing

Place the flush connector and polishing fixture on the dull side of the 3- μ m pink lapping film, and continue to polish the fiber in the same figure-eight pattern for approximately 25 strokes. The fiber end should be flat, smooth, and clean.

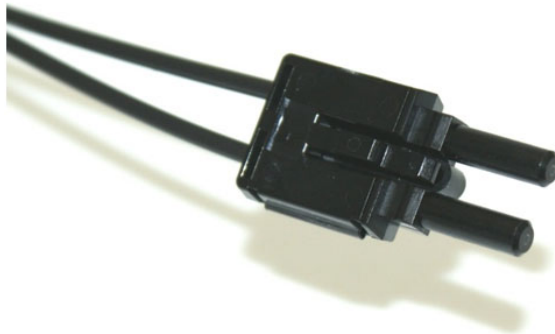

NOTE: Use of the pink lapping film fine polishing step results in up to 0.5-dB improvement in coupling performance of either a transmitter-receiver link or a bulkhead/splice over a 600 grit polish alone. This fine polish is comparable to the Broadcom factory polish. The fine polishing step can be omitted for short link lengths.

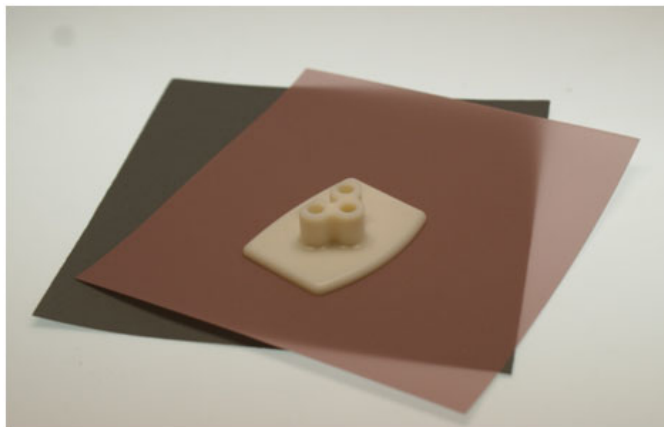
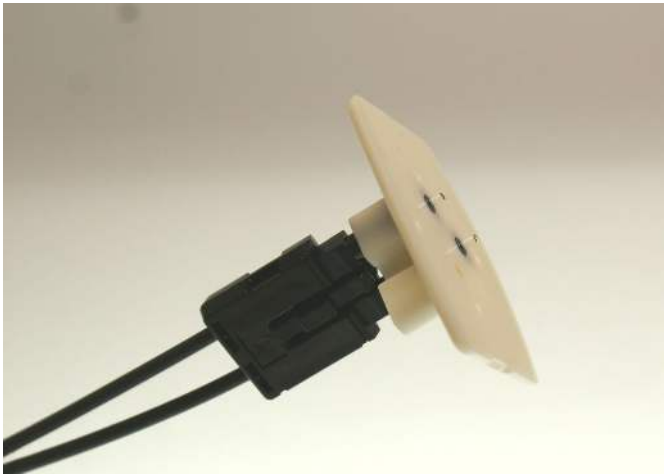

Package Dimensions

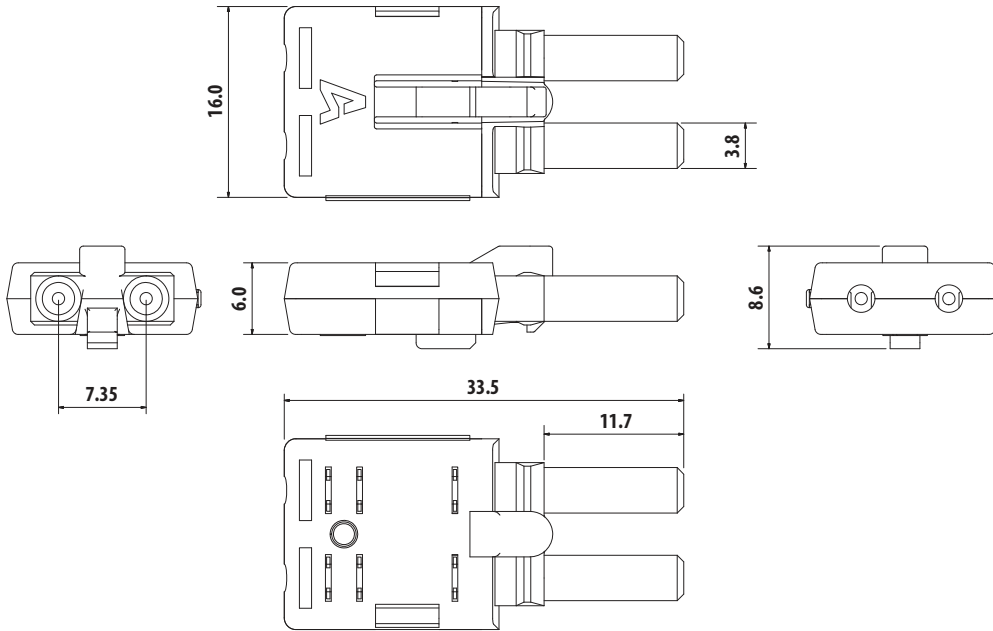

NOTE: Dimensions are in millimeters (mm).

Ordering Guide for POF Cable

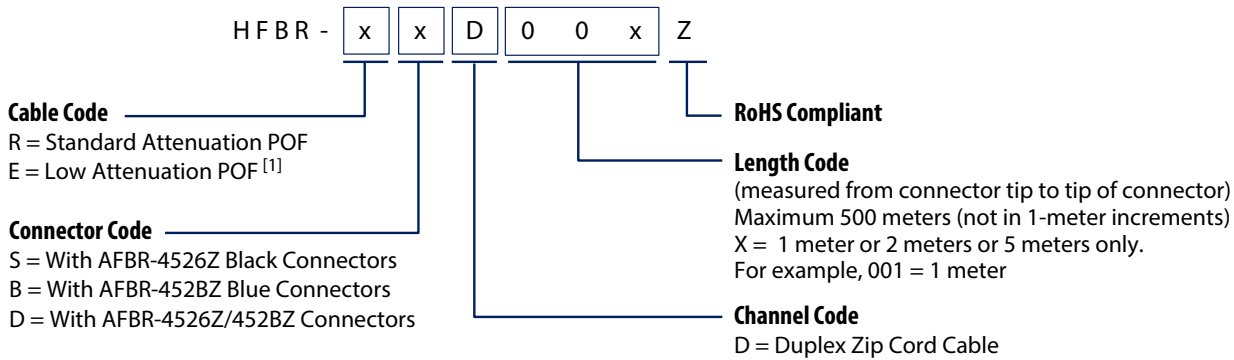

1. Standard (type = "R") and Low Attenuation (type = "E") cables comply with UL VW-1 flame retardant specification (UL file # E89328).
Note: For other cable lengths please contact a Broadcom representative.

Example: HFBR-RSD002Z is a Standard attenuation, AFBR-4526Z Duplex connectors, 2 meters cable.

Cable Length Tolerances

The plastic cable length tolerances are +10% / 0%.

Copyright © 2005–2022 Broadcom. All Rights Reserved. The term “Broadcom” refers to Broadcom Inc. and/or its subsidiaries. For more information, go to www.broadcom.com. All trademarks, trade names, service marks, and logos referenced herein belong to their respective companies.

Broadcom reserves the right to make changes without further notice to any products or data herein to improve reliability, function, or design. Information furnished by Broadcom is believed to be accurate and reliable. However, Broadcom does not assume any liability arising out of the application or use of this information, nor the application or use of any product or circuit described herein, neither does it convey any license under its patent rights nor the rights of others.