



# AC 3200 JHU

## INDEX

<b>1</b>	<b>General</b> .....	<b>3</b>
<b>2</b>	<b>Mechanics</b> .....	<b>3</b>
2.1	General.....	3
2.2	Connections.....	4
<b>3</b>	<b>Operating Data</b> .....	<b>5</b>
3.1	Operating Data - Electrical Interface - Input.....	5
3.2	Electrical Operating Data .....	5
3.3	Operating Data - Electrical Interface -Output .....	5
3.4	Electrical Features.....	6
3.5	Aerodynamic.....	6
3.6	Sound Data.....	8
<b>4</b>	<b>Environment</b> .....	<b>8</b>
4.1	General.....	8
4.2	Climatic requirements*) .....	8
<b>5</b>	<b>Safety</b> .....	<b>9</b>
5.1	Electrical Safety.....	9
5.2	Approval Tests .....	9
<b>6</b>	<b>Reliability</b> .....	<b>9</b>
6.1	General.....	9

**1 General**

Fan type	Fan
Rotational direction looking at rotor	counterclockwise
Airflow direction	Air outlet over struts
Bearing system	Ball bearing
Mounting position	any

**2 Mechanics****2.1 General**

Width	92,0 mm	
Height	92,0 mm	
Depth	72,0 mm	
Diameter	0,0 mm	
Weight	0,325 kg	
Housing material	Plastic	
Impeller material	Plastic	

## 2.2 Connections

Electrical connection	Wires	
Length of lead wire	L = 450 mm	
Tolerance	+ - 10,0 mm	
Length of tube	S = 15 mm	
Tolerance	+ - 5 mm	
Wire gauge (AWG)	22	
Insulation diameter		
Plug	see drawing	
Contact	see drawing	



	Colour	Operation
Wire 1	black	L1
Wire 2	black	L2

### 3 Operating Data

#### 3.1 Operating Data - Electrical Interface - Input

External voltage supply for input and output signals must be SELV conform.

Control input	None
---------------	------

#### 3.2 Electrical Operating Data

Features	Condition	Symbol	Values			
Voltage range	$\Delta p = 0$	U	85 V		265 V	115 V / 230 V
Nominal voltage	$\Delta p = 0$	$U_N$		115 V / 230 V		
Frequency	$\Delta p = 0$	f	50 Hz			60 Hz
Power consumption Tolerance	$\Delta p = 0$	P	12 W +/- 20 %	12 W +/- 20 %	12 W +/- 25 %	12 W +/- 22,5 %
Speed Tolerance	$\Delta p = 0$	n	6.800 1/min +/- 10 %	6.800 1/min +/- 10 %	6.800 1/min +/- 10 %	6.800 1/min +/- 10 %

#### 3.3 Operating Data - Electrical Interface -Output

External voltage supply for input and output signals must be SELV conform.

Tacho type	None
------------	------

Alarm type	None
------------	------

**3.4 Electrical Features**

Electronic function	None	
Locked rotor protection	Auto restart	
Clock signal t3/t4 at locked rotor	Typical: 0,5 s / 11 s	

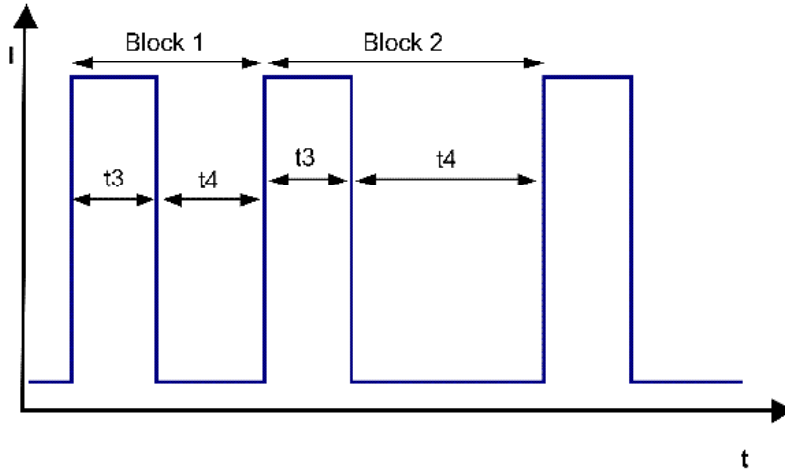

**3.5 Aerodynamic**

Measurement conditions: Measured with a double chamber intake rig acc. to DIN EN ISO 5801. Normal air density = 1,2 kg/m<sup>3</sup>; Temperature 23°C +/- 3°C; In the intake and outlet area should not be any solid obstruction within 0,5 m. The information is only valid under the specified test conditions and may be changed by the installation conditions. If there are deviations from the standard test conditions, the characteristic values must be checked under the installed conditions.

a) Operation condition: 6.800 1/min at free air flow      Frequency: 50 Hz      Nominal voltage: 115 V / 230 V

Max. free-air flow ( $\Delta p = 0 / \dot{v} = \text{max.}$ )	144,0 m <sup>3</sup> /h
Max. static pressure ( $\Delta p = \text{max.} / \dot{v} = 0$ )	260 Pa

b) Operation condition: 6.800 1/min at free air flow      Frequency: 60 Hz      Nominal voltage: 115 V / 230 V

Max. free-air flow ( $\Delta p = 0 / \dot{v} = \text{max.}$ )	144,0 m <sup>3</sup> /h
Max. static pressure ( $\Delta p = \text{max.} / \dot{v} = 0$ )	260 Pa

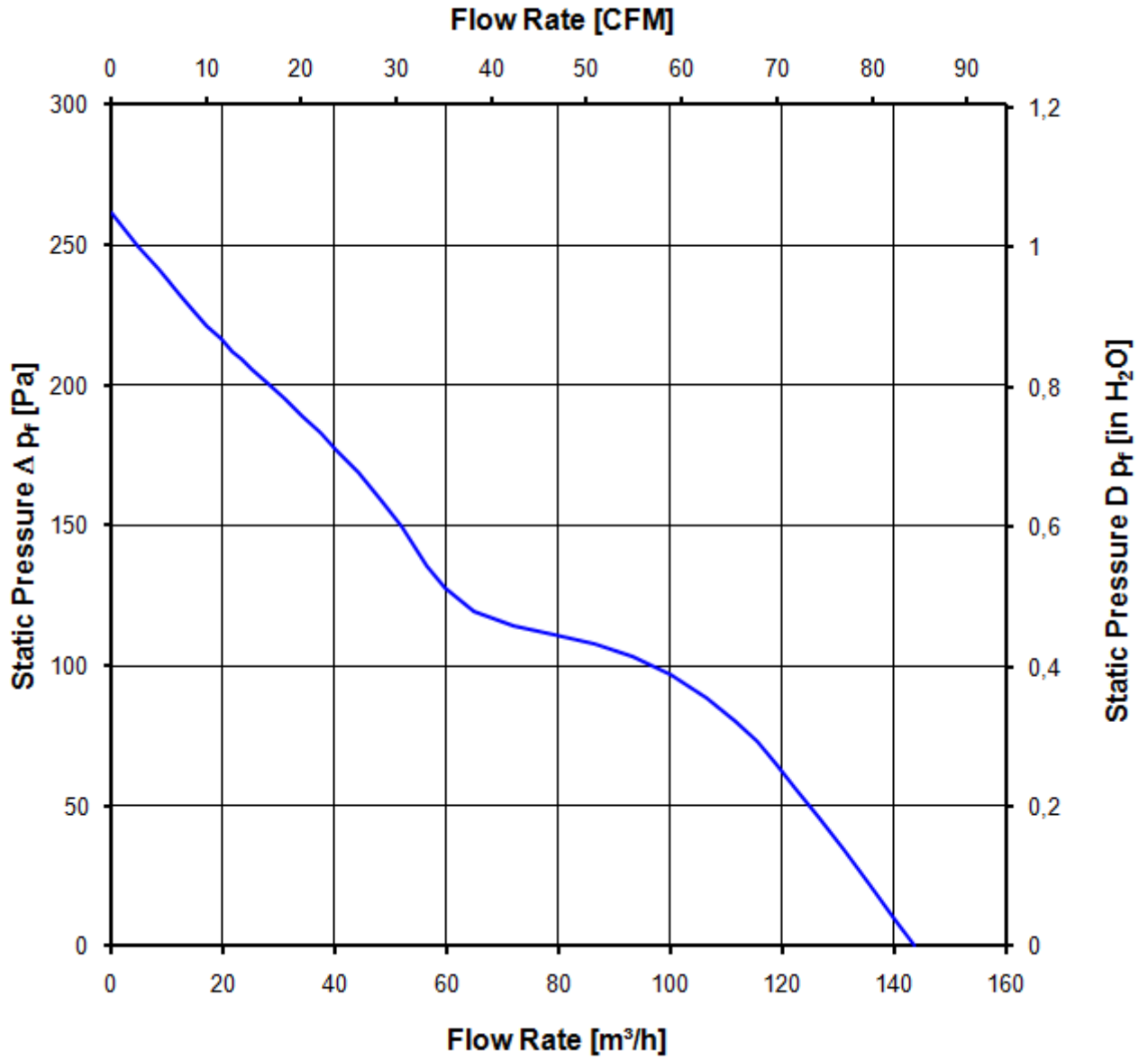

### 3.6 Sound Data

Measurement conditions: Sound pressure level: 1 Meter distance between microphone and the air intake.  
 Sound power level: Acc. to DIN 45635 part 38 (ISO 10302)  
 Measured in a semianchoic chamber with a background noise level of  $L_p(A) < 5 \text{ dB(A)}$   
 For further measurement conditions see section 3.4

a) Operation condition: 6.800 1/min at free air flow      Frequency: 50 Hz      Nominal voltage: 115 V / 230 V

Optimal operating point	92,0 m <sup>3</sup> /h @ 100 Pa	
Sound power level at the optimal operating point	6,4 bel(A)	
Sound pressure level at free air flow, measured in rubber bands	55,0 dB(A)	

b) Operation condition: 6.800 1/min at free air flow      Frequency: 60 Hz      Nominal voltage: 115 V / 230 V

Optimal operating point	92,0 m <sup>3</sup> /h @ 100 Pa	
Sound power level at the optimal operating point	6,4 bel(A)	
Sound pressure level at free air flow, measured in rubber bands	55,0 dB(A)	

## 4 Environment

### 4.1 General

Min. permitted ambient temperature TU min.	-20 °C	
Max. permitted ambient temperature TU max.	70 °C	
Min. permitted storage temperature TL min.	-40 °C	
Max. permitted storage temperature TL max.	80 °C	

### 4.2 Climatic requirements\*)

IP-protection type (certified)	IP 65 (for fan only, not for connector if applicable) **)	
Humidity requirements	humid temperature, cyclic; according to DIN EN 60068-2-38, 10 cycle and condensation water check; according to DIN EN ISO 6270-2, 14 days	
Radiation exposure	Solar radiation; according to DIN EN 60068-2-5	
Salt fog requirements	None	
Harmful gas requirements	None	

\*) Permitted application area:  
 The product is for the use in partial sheltered rooms or open, roofed areas. Direct exposure to water is allowed provided that this does not prevent the normal operation. Saline ambient conditions must be avoided.

Pollution degree 3 (according DIN EN 60664-1)  
 It occurs conductive pollution or dry non-conductive pollution which becomes conductive due to condensation.



\*\*\*) The specification of the IP protection refers to the conditions mentioned in certification of the fan. The above mentioned short description of the protection scope is not final. For detailed information of the respective protection scope and definitions, see certification as well as DIN EN 60529 (protection by housings) and ISO 20653 (for vehicles) with the letter K.

**Short description of the IP-protection type:**

Solid particle Protection: Dust tight.

Protection against deliberate contact: Protected against contact to hazardous parts with a wire.

Protection against water: Protected against water jets.

**5 Safety**

**5.1 Electrical Safety**

A verification of thermal conditions (normal and abnormal operation) as well as the protection against electric shock, ingress of solid foreign objects and water has to be done in conjunction with the appliance.

Test voltage HV type test	1500 V
Unit test voltage	VAC
Time type test HV	1 s
Insulation resistance	RI > 10 MOhm
Protection class	built-in fan

**5.2 Approval Tests**

CE	Yes
UL	Yes
VDE	Yes
CSA	Yes
CCC	Yes

According to the guidelines on the application of Directive 2006/95/EC, chapter III: Scope of the "low voltage" directive, paragraph: Are "components" included in the scope? the following has to be applied:

However, some types of electrical devices, designed and manufactured for being uses as basic components to be incorporated into other electrical equipment, are such that their safety to a very large extent depends on how they are integrated into the final product and the overall characteristics of the final product. These basic components include electronic and certain other components.

Taking into account these objectives of the "Low Voltage" Directive, such basic components, the safety of which can only, to a very large extend, be assessed taking into account, how they are incorporated and for which a risk assessment cannot be undertaken, then they are not covered as such by the Directive. In particular, they must not be CE marked unless covered by other Community legislation that requires CE marking.

**6 Reliability**

**6.1 General**

Life expectancy L10 at TU = 40 °C	70.000 h	
Life expectancy L10 at TU max.	35.000 h	

Copying of this document, and giving its status and the use or communication of the contents thereof, are forbidden without express authorisation. If necessary, please refer to the patent or the registration of a utility model or design. In the event of the grant of a patent or the registration of a utility model or design.

Subcontractors must refer to the drawing and the use or communication of the contents thereof, are forbidden without express authorisation. If necessary, please refer to the patent or the registration of a utility model or design. In the event of the grant of a patent or the registration of a utility model or design.

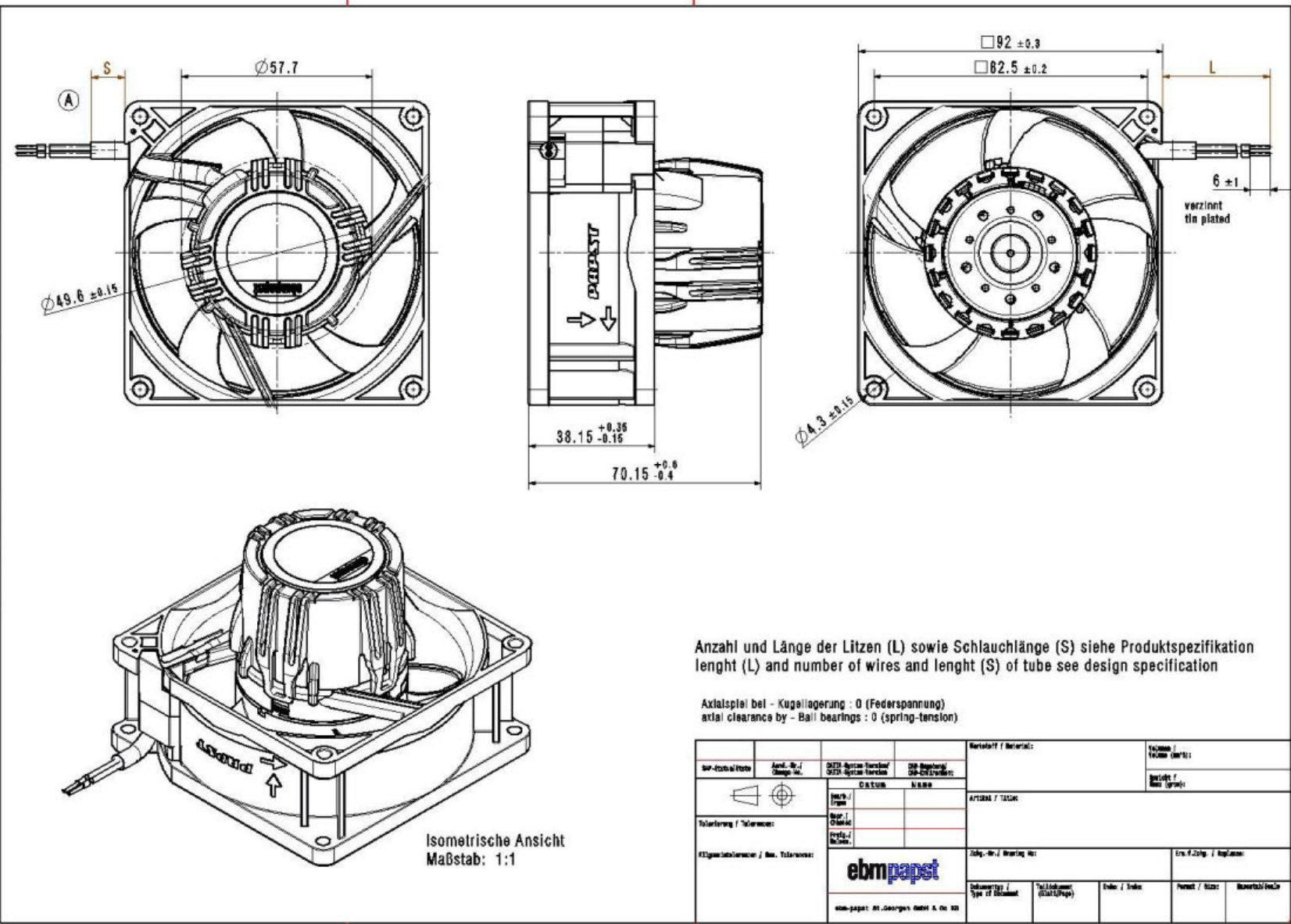

Anzahl und Länge der Litzen (L) sowie Schlauchlänge (S) siehe Produktspezifikation  
 length (L) and number of wires and length (S) of tube see design specification

Axialspiel bei - Kugellagerung : 0 (Federspannung)  
 axial clearance by - Ball bearings : 0 (spring-tension)

Isometrische Ansicht  
 Maßstab: 1:1

SW-Instanz/Instanz 	Art.-Nr. / Design No.	D220-Optocoupler D220-Optocoupler	D220-Optocoupler D220-Optocoupler	Material / Material:	Teilname / Part Name:
		Datum / Date		Artikel / Article:	Gewicht / Mass (grams):
Tolerierung / Tolerances:	Maß / Dimension:	Maß / Dimension:	Maß / Dimension:	Artikel / Article:	Gewicht / Mass (grams):
Eigenschaften / Features:			Zeichnung / Drawing No:	Ein- / Stück / Qty. / Piece:	
www.ebmpapst.com	Teilname / Part Name:	Ein- / Stück / Qty. / Piece:	Part / Size:	Material / Material:	