

Mini-Mac™
Applicator

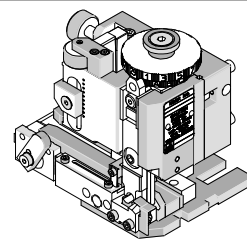

Application Tooling Specification Sheet



Order No.63832-6400

FEATURES

- Directly adapts to most automatic wire processing machines
- Applicator designed to industry standard mounting and shut height 135.80mm (5.346")
- Quick set-up time; plus, the crimp height, track and feed adjustments can be set without removing the applicator from the press
- Fine adjustment allows users to achieve target with little effort by adjusting in increments of .015mm (.0006") for conductor crimp height and .063mm (.0025") for insulation height
- Independent adjustment rings allow users to quickly adjust the conductor or insulation crimp height without affecting each other.

SCOPE

Products: Female Power Contact Crimp Terminals 8 AWG and 12 Doubles.

Terminal Series No.	Terminal Order No.		Wire Size		Insulation Diameter Maximum				Strip Length Maximum	
			AWG	mm ²	mm		In.		mm	In.
44262	44262-4304	44262-4334	8 and 12(2)	8.50 and 3.30(2)	N/A	N/A	N/A	N/A	6.35	.250
	44262-4404	44262-4434								
	44262-4504	44262-4534								
	44262-4604	44262-4634								
173693	173693-4634		8 and 12(2)	8.50 and 3.30(2)	N/A	N/A	N/A	N/A	6.35	.250

DEFINITION OF TERMS

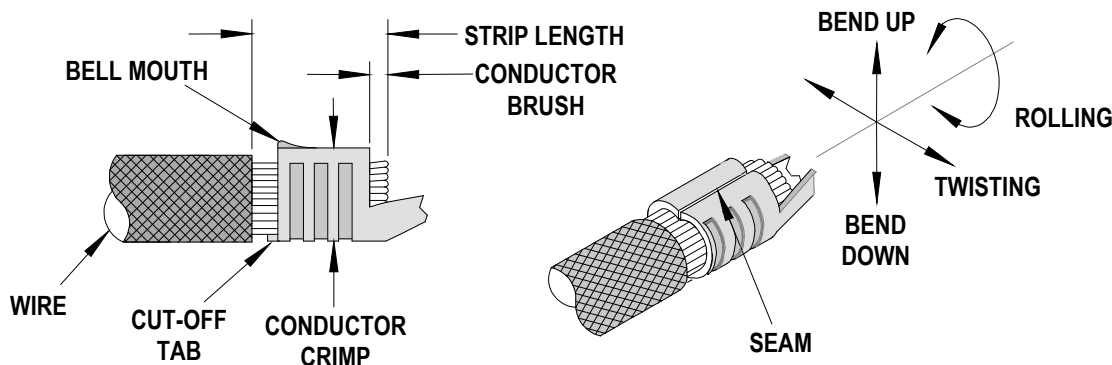

The above terminal drawing is a generic terminal representation. It is not an image of any terminal listed in the scope.

CRIMP SPECIFICATION

Terminal Series No.	Bell Mouth		Cut-Off Tab Maximum		Conductor Brush	
	mm	In.	mm	In.	mm	In.
44262	0.25-1.25	.010-.049	0.50	.020	0.64-1.90	.025-.075
173693						

Terminal Series No.	Bend Up	Bend Down	Twist	Roll	Punch Width (Ref)				Seam
	Degree		Degree		Conductor		Insulation		
					mm	In	mm	In	
44262	3	3	3	3	5.70	.224	N/A	N/A	Seam shall not be open, and no wire allowed out of the crimping area.
173693									

After crimping, the crimp profiles should measure the following:

Terminal Series No.	Wire Size		Conductor				Pull Force Minimum	
			Crimp Height		Crimp Width (Ref.)			
	AWG	mm ²	mm	In.	mm	In.	N	Lb.
44262	8	8.50	3.55-3.65	.140-.144	5.80	.228	400.34	90.0
	12 (2)	3.31 (2)	3.30-3.40	.130-.134	5.80	.228	311.38	70.0
173693	8	8.50	3.55-3.65	.140-.144	5.80	.228	400.34	90.0
	12 (2)	3.31 (2)	3.30-3.40	.130-.134	5.80	.228	311.38	70.0

* This applicator was qualified to the above specifications with UL 1015 and UL 1028 wire.

Tool Qualification Notes:

1. The above specifications are guidelines to an optimum crimp.

PARTS LIST

Mini-Mac™ Applicator 63832-6400				
Item	Order No	Engineering No.	Description	Quantity
Perishable Tooling				
	63832-6470	63832-6470	Tool Kit (All "Y" Items)	REF
1	63465-0055	63465-0055	Conductor Punch	1 Y
2	63455-0050	63455-0050	Conductor Anvil	1 Y
3	63443-0095	63443-0095	Front Cut-Off Plunger	1 Y
4	63890-0487	63890-0487	Front Plunger Retainer	1 Y
Other Components				
5	63821-0012	63821-0012	Feed Guide	1
6	11-18-4848	60800A123	Spring Retainer	1
7	11-18-4849	60800A124	Wire Hold Down Spring	1
8	63443-0024	63443-0024	Key	1
9	63443-1720	63443-1720	Height Spacer (19.00mm)	1
10	63443-2216	63443-2216	Course Spacer (16.00mm)	1
11	63443-2302	63443-2302	Fine Spacer (3.10mm)	1
12	63443-6130	63443-6130	Rear Cover	1
13	63466-0509	63466-0509	Striker-Flat Bottom	1
14	63700-0539	63700-0539	Compression Spring	1
15	63821-0015	63821-0015	Wire Stop	1
16	63890-0866	63890-0866	Bushing-Punch (Conductor)	1
Frame				
17	63801-3201	63801-3201	Top	1
18	63801-3281	63801-3281	Base	1
19	63801-4650	63801-4650	Track	1
Hardware				
20	N/A	N/A	M3 by 6 Long FHCS	1**
21	N/A	N/A	M3 by 6 Long SHCS	2**
22	N/A	N/A	M4 by 12 Long BHCS	2**
23	N/A	N/A	M4 by 50 Long SHCS	2**
24	N/A	N/A	M5 by 12 Long SHCS	1**
25	N/A	N/A	M8 by 30 Long BHCS	1**
26	N/A	N/A	2mm by 5 Long Roll Pin	1**
** Available from an industrial supply company such as MSC (1-800-645-7270).				

Assembly Drawing

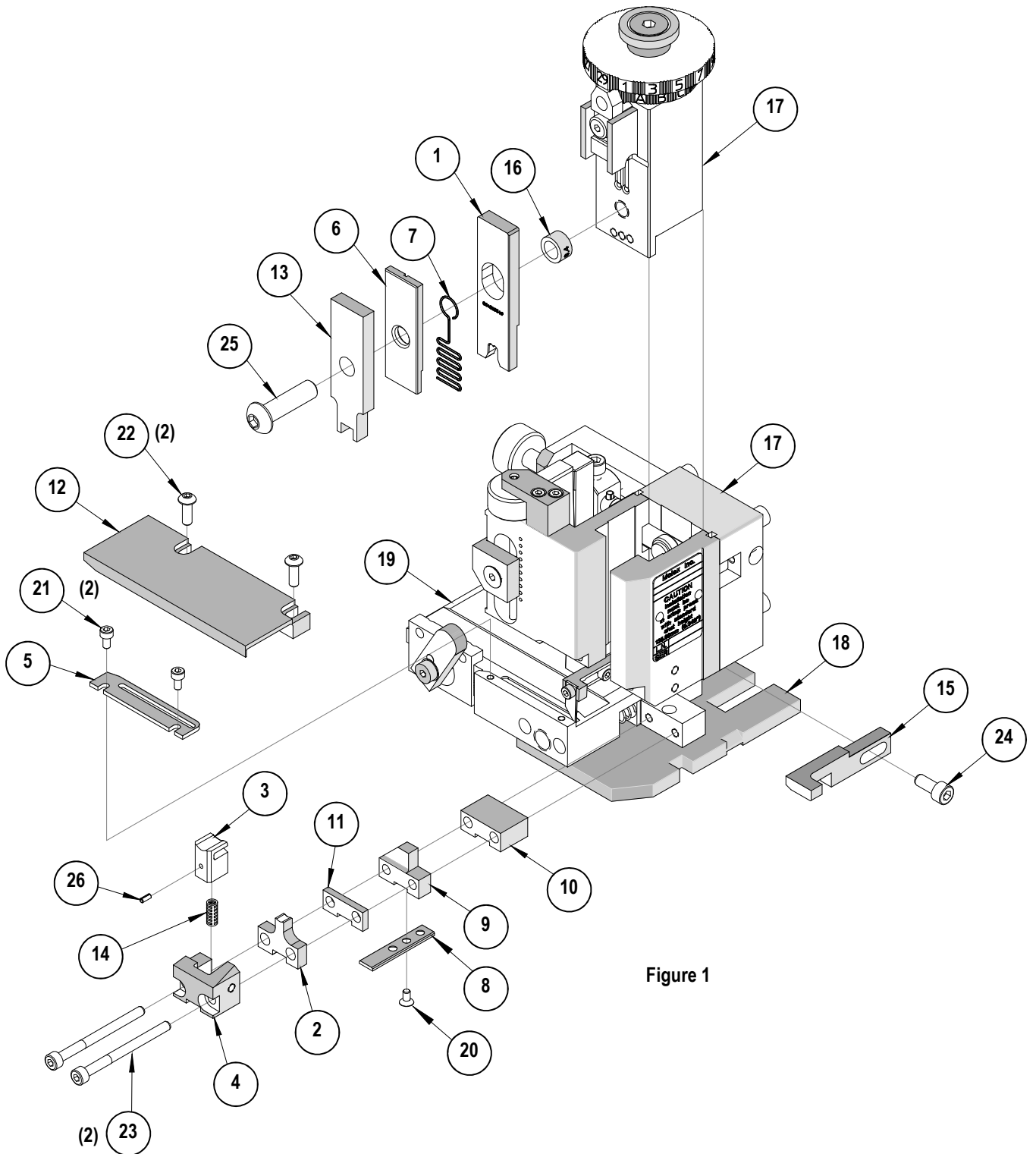

Figure 1

NOTES

1. Molex recommends an extra perishable tooling kit be maintained at your facility.
2. Verify tooling alignment by manually cycling the press with applicator before crimping under power. Check that all screws are tight.
3. Slugs, terminals, dirt and oil should be kept clear of work area.
4. Wear safety glasses at all times.
5. For recommended maintenance, refer to the Mini-Mac™ Applicator Manual (Document No. 63880-0000).

CAUTION: This applicator should only be used in a press with a shut height of 135.80 mm (5.346"). Tooling damage could result at a lower setting.

CAUTION: To prevent injury, never operate this applicator without the guards supplied with the press or wire-processing machine in place. Reference the press or wire processing manufacturer's instruction manual.

CAUTION: Molex crimp specifications are valid only when used with Molex terminals, applicators and tooling.

Application Tooling Support

Phone: +1-402-458-TOOL (8665)

E-Mail: applicationtooling@molex.com

Website: www.molex.com/applicationtooling