

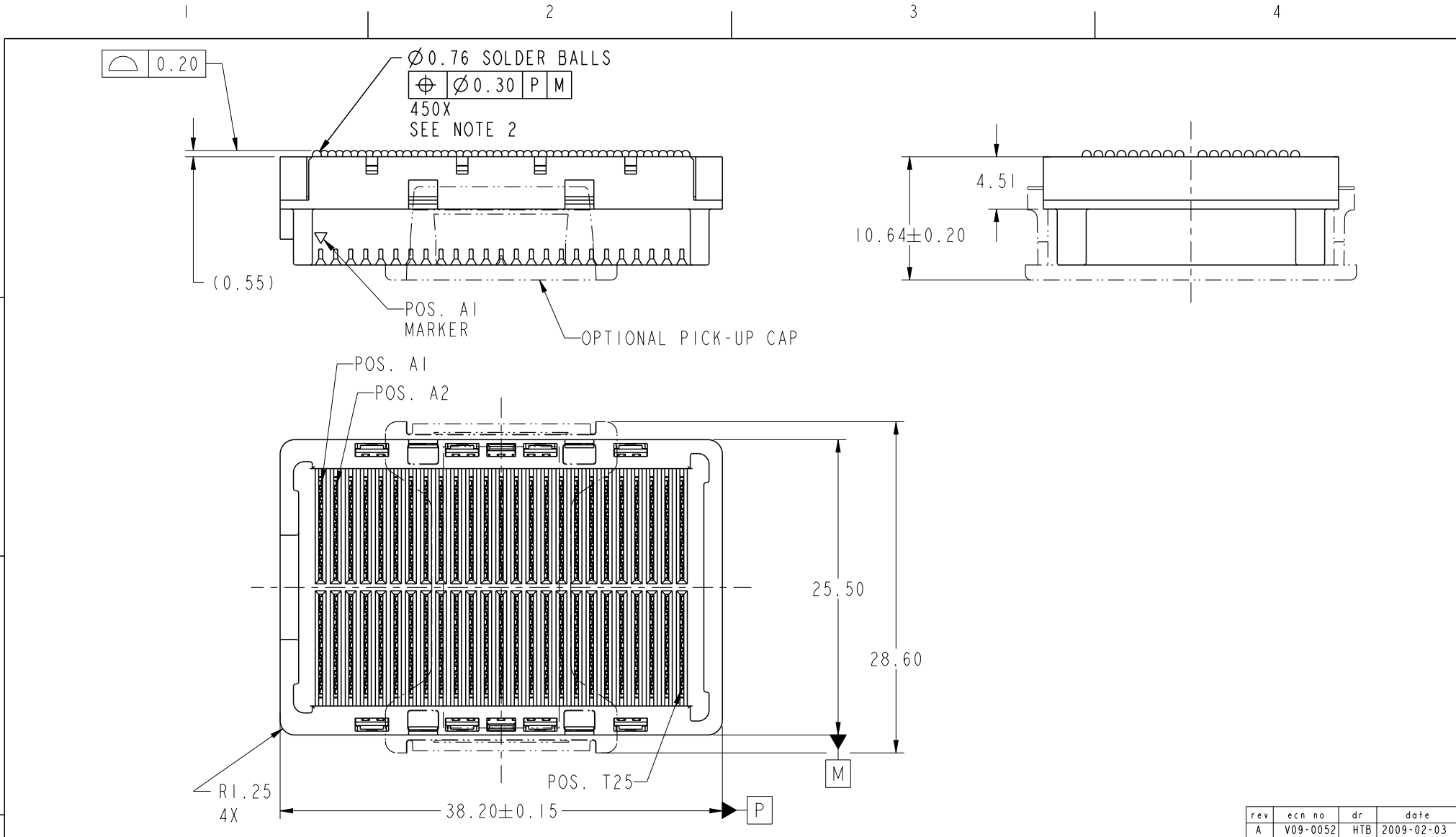

Copyright FCI.



rev	ecn no	dr	date
A	V09-0052	HTB	2009-02-03

spec ref	*	dr	Louis Ng	2010/11/01	projection	mm	size	A4	scale	11:10
tolerance std	ASME Y14.5	eng	Nickor Zuo	2011/05/31			ecn no	ELX-DG-003943-1		
		chr	Alex Cao	2011/06/24				rel level	Released	
surface	✓	appr	Pei-Ming Zheng	2011/06/27	product family	GIG-Array				
					title	5mm RECEPTACLE ASSY.		dwg no	10097161	
					cat. no.	Product - Customer Drw		rev	B	
								sheet	1 of 5	

ProE File - REV C - 2009-06-09

A

B

C

D

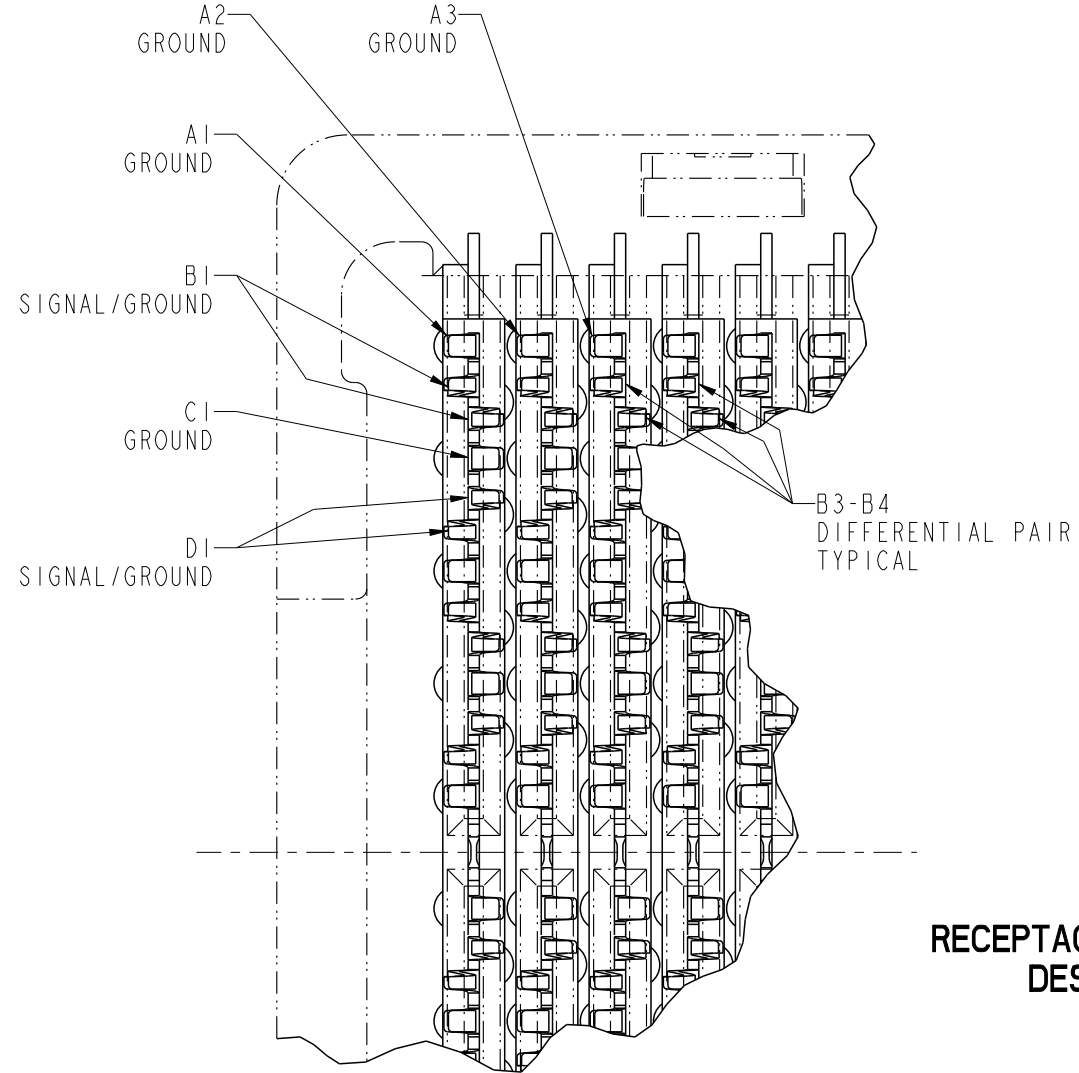

RECEPTACLE INTERFACE DESCRIPTION



Copyright FCI.

spec ref *		dr Louis Ng		2010/11/01	projection 	mm 	size A4	scale 37:5
tolerance std ASME Y14.5		eng Nickor Zuo		2011/05/31			ecn no ELX-DG-003943-1	
-		chr Alex Cao		2011/06/24			rel level Released	
surface		appr Pei-Ming Zheng		2011/06/27	product family GIG-Array		rev	
-		linear	0.X ±0.30		title 5mm RECEPTACLE ASSY.		dwg no 10097161	B
			0.XX ±0.10		200 SIG. POS. WITH NITROGEN BGA			
			0.XXX ±0.05		cat. no. *			
		angular	0° ±2°	www.fci.com		Product - Customer Drw		sheet 3 of 5

PreE File - REV C - 2009-06-09

FLAT AREA
FOR OPTIONAL
PICK-UP CAP
SCALE 2:1

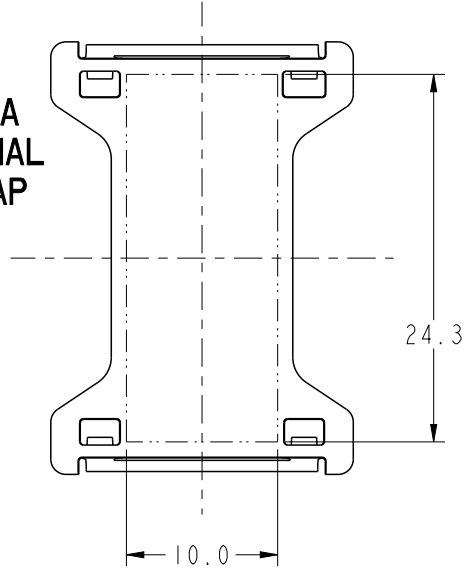

DIM "A" REF.
MATED HEIGHT
AFTER REFLOW
SEE NOTE 3.

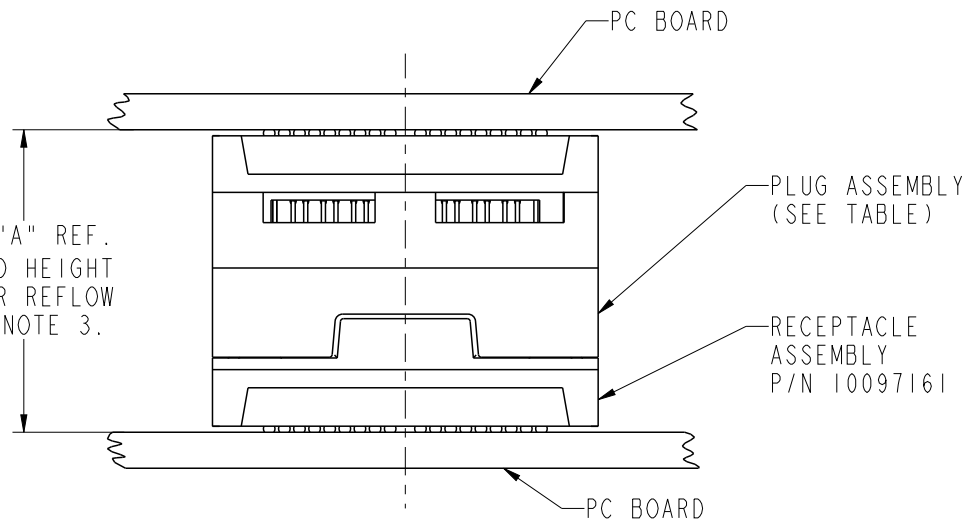

END VIEW OF MATED CONNECTORS
SCALE 2:1

DIM. "A"	PLUG ASSEMBLY P/N
15	55737
17	10026802
18	10060910
20	55738
25	55739
30	10054783



Copyright FCI.

spec ref	*	dr	Louis Ng	2010/11/01	projection 	mm 	size	A4	scale	1:10				
tolerance std	TOLERANCES UNLESS OTHERWISE SPECIFIED	eng	Nickor Zuo	2011/05/31			ecn no	ELX-DG-003943-1						
ASME Y14.5		chr	Alex Cao	2011/06/24				rel level	Released					
-		appr	Pei-Ming Zheng	2011/06/27			product family		GIG-Array					
surface	linear	0.X	±0.30		title	5mm RECEPTACLE ASSY. 200 SIG. POS. WITH NITROGEN BGA	dwg no	10097161	rev	B				
		0.XX	±0.10							www.fci.com	cat. no.	*	Product - Customer Drw	sheet 4 of 5
		0.XXX	±0.05											
	angular	0°	±2°											

PrdE File - REV C - 2009-06-09

PRODUCT NUMBER	SOLDER BALL COMPOSITION	CONTACT PLATING PERFORMANCE LEVEL
10097161-001	STANDARD (EUTECTIC)	PERFORMANCE-BASED PLATING, QUALIFIED TO MEET THE REQUIREMENTS OF FCI PRODUCT SPECIFICATION GS-12-192, INCLUDING TELCORDIA CENTRAL OFFICE
10097161-001LF	LEADFREE	

NOTES:

- ① MATERIAL:
HOUSING: LCP
CONTACT: COPPER ALLOY
PLATING (CONTACT): Au OVER Ni.
UL RATING: 94 V-0
SOLDBALL: (SEE TABLE) EUTECTIC SnPb OR LEAD FREE 95.5 Sn/4Ag/0.5Cu.
- ② SOLDER BALLS WILL NOT BE PERFECT SPHERICAL SHAPE DUE TO REFLOW ATTACHMENT.
- ③ MATED HEIGHT EFFECTED BY CUSTOMERS' PCB PAD SIZE, PLATING, SOLDER REFLOW PROFILE & SOLDER PASTE.
- ④ CONTACTS IN ROWS A,C,E,G,J,K,M,P,R AND T ARE SINGLE BEAM CONTACTS, TYPICALLY USED AS GROUND PINS. (NOTE: CONTACTS IN ROWS J & K ARE TIED TOGETHER [COMMONED])
- ⑤ CONTACTS IN ROWS B,D,F,H,L,N,Q AND S ARE DUAL BEAM CONTACTS, TYPICALLY USED AS SIGNAL PINS.
- ⑥ SPECIFIED POSITIONAL TOLERANCE DEFINES PAD TO PAD LOCATION WITHIN LAND PATTERN. POSITIONAL TOLERANCE OF LAND PATTERN TO FUDICIAL MARKS OR PCB DATUMS SHALL BE DEFINED BY CUSTOMER. FOR RECOMMENDED PRODUCT APPLICATION AND PCB DESIGN DETAILS, SEE DOC. NO. GS-20-016.
- ⑦ FOR PROPER APPLICATION FOLLOW FCI APPLICATION SPECIFICATION GS-20-033. LEAD FREE SOLDER BALLS WILL NOT SOLDER PROPERLY IN A LEADED SOLDER PROCESS DUE TO A HIGHER REFLOW TEMPERATURE. LEADFREE PRODUCT IS THEREFORE NOT BACKWARDS COMPATIBLE WITH LEADED OR SOME SOLDERING APPLICATIONS. REFERENCE FCI APPLICATION SPECIFICATION.
- ⑧ THIS PRODUCT MEETS THE EUROPEAN UNION DIRECTIVES AND OTHER COUNTRY REGULATIONS AS DESCRIBED IN GS-22-008. PRODUCT MEETING THIS DIRECTIVE IS IDENTIFIED IN THE CODE NUMBER MARKED ON EACH PART BY HAVING AN "X" IN THE SEVENTH CHARACTER POSITION.



Copyright FCI.

spec ref	*	dr	Louis Ng	2010/11/01	projection 	mm 	size	A4	scale	1:10				
tolerance std	TOLERANCES UNLESS OTHERWISE SPECIFIED	eng	Nickor Zuo	2011/05/31			ecn no	ELX-DG-003943-1						
ASME Y14.5		chr	Alex Cao	2011/06/24				rel level	Released					
-		appr	Pei-Ming Zheng	2011/06/27	product family	GIG-Array								
surface	✓	linear	0.X	±0.30	FCI	title	5mm RECEPTACLE ASSY.	dwg no	10097161	rev				
-			0.XX	±0.10							www.fci.com	cat. no.	*	Product - Customer Drw
-			0.XXX	±0.05										
-	angular	0°	±2°											