

SP1ML 868 MHz wireless sensor board powered by a coin cell battery

Data brief

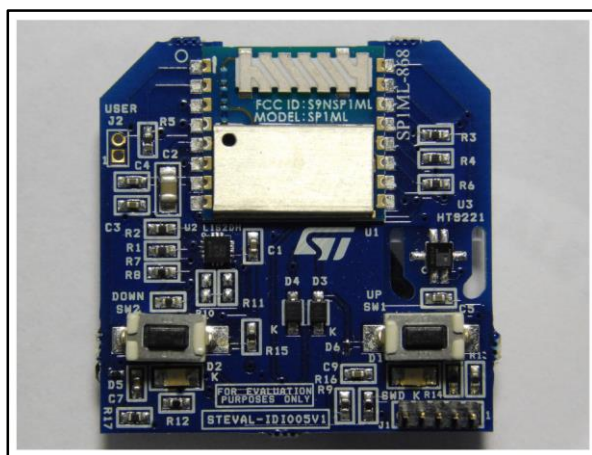

Description

The STEVAL-IDI005V1 is an SP1ML-based wireless sensor board powered by a CR2032 coin-cell battery. It can communicate with the STEVAL-SP1ML868 using the P2P AT command set. The board can be programmed through an external 5-pin SWD connector.

The board is designed to provide several sample, sub-GHz, Smart Home and Smart Things applications, such as heat allocator, smart remote control and wireless sensor node with 868 MHz sub-GHz connectivity.

Features

- Wireless sensor board powered by coin cell battery, CR2032
- 868 MHz sub-GHz connectivity, based on the SP1ML-868 certified module
- Sensors on board:
 - LIS2DH MEMS accelerometer
 - HTS221 humidity and temperature sensor
- ESD protection
- 2 LEDs and 2 buttons
- SWD connector for debug and reprogramming
- Sample firmware for P2P communication with the STEVAL-SP1ML868 using AT commands, to display various sensor data (motion, humidity, temperature) and board status on serial utilities like HyperTerminal
- RoHS compliant

1 Schematic diagram

Figure 1: STEVAL-IDI005V1 circuit schematic (1 of 3)

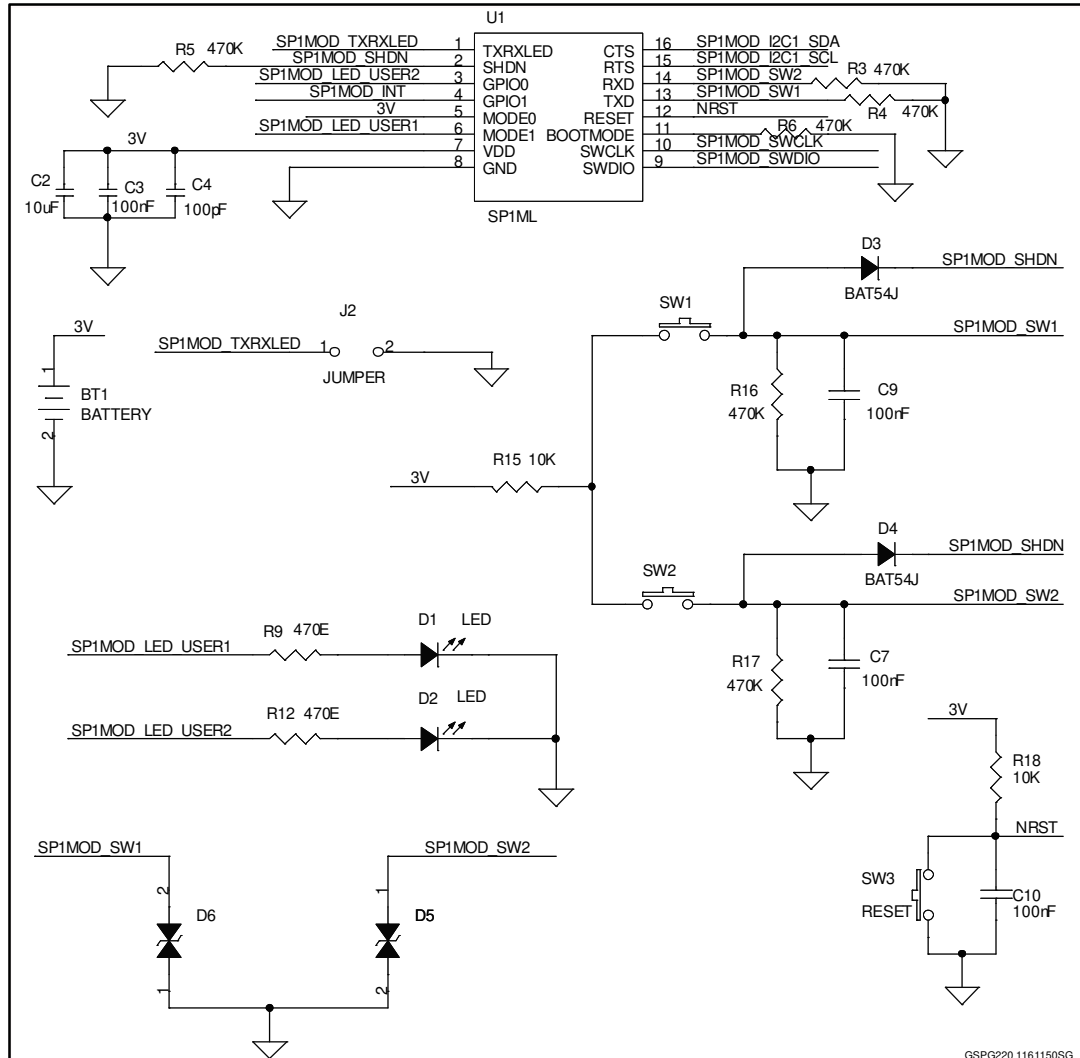

GSPG220 1161150SG

Figure 2: STEVAL-IDI005V1 circuit schematic (2 of 3)

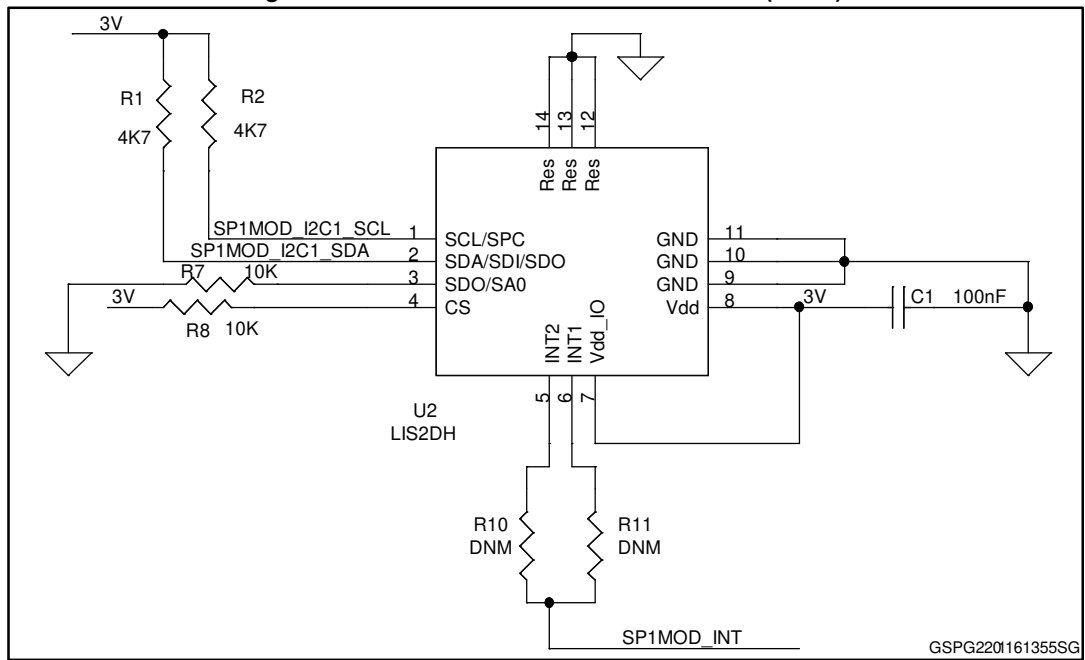
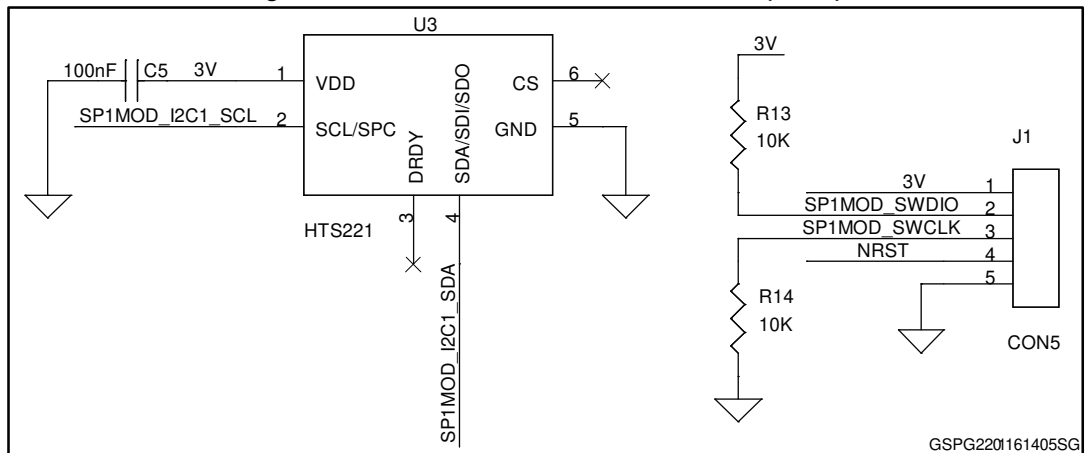

Figure 3: STEVAL-IDI005V1 circuit schematic (3 of 3)



2 Revision history

Table 1: Document revision history

Date	Version	Changes
26-Jan-2016	1	Initial release.

IMPORTANT NOTICE – PLEASE READ CAREFULLY

STMicroelectronics NV and its subsidiaries (“ST”) reserve the right to make changes, corrections, enhancements, modifications, and improvements to ST products and/or to this document at any time without notice. Purchasers should obtain the latest relevant information on ST products before placing orders. ST products are sold pursuant to ST’s terms and conditions of sale in place at the time of order acknowledgement.

Purchasers are solely responsible for the choice, selection, and use of ST products and ST assumes no liability for application assistance or the design of Purchasers’ products.

No license, express or implied, to any intellectual property right is granted by ST herein.

Resale of ST products with provisions different from the information set forth herein shall void any warranty granted by ST for such product.

ST and the ST logo are trademarks of ST. All other product or service names are the property of their respective owners.

Information in this document supersedes and replaces information previously supplied in any prior versions of this document.

© 2016 STMicroelectronics – All rights reserved