

Adjustable, 500mA LDO Regulator with Enable

General Description

The RT9179A is a high performance linear voltage regulator with enable high function and adjustable output with a 1.175V reference voltage. It operates from an input of 3V to 5.5V and provides output current up to 500mA with two external resistors to set the output voltage ranges from 1.175V to 4.5V.

The RT9179A has superior regulation over variations in line and load. Also it provides fast response to step changes in load. Other features include over-current and over-temperature protection. The device has enable pin to reduce power consumption in shutdown mode.

The device is available in SOP-8 package.

Ordering Information

RT9179A □ □

- Package Type
S : SOP-8
- Lead Plating System
P : Pb Free
G : Green (Halogen Free and Pb Free)

Note :

Richtek products are :

- ▶ RoHS compliant and compatible with the current requirements of IPC/JEDEC J-STD-020.
- ▶ Suitable for use in SnPb or Pb-free soldering processes.

Typical Application Circuit

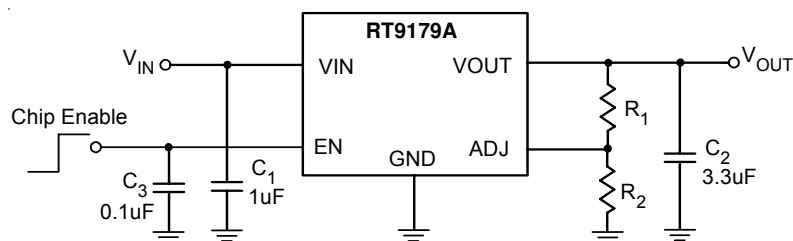

$$V_{OUT} = 1.175 \times \left(1 + \frac{R_1}{R_2} \right) \text{ Volts}$$

Note: R2 around 200kΩ is recommended.
Refer to the "Application Information" for C_{OUT} selection.

Features

- 400mV Dropout @ 500mA
- 150µA Low Quiescent Current
- Excellent Line and Load Regulation
- <1µA Standby Current in Shutdown Mode
- Guaranteed 500mA Output Current
- Adjustable Output Voltage Ranges from 1.175V to 4.5V
- Over-Temperature/Over-Current Protection
- RoHS Compliant and 100% Lead (Pb)-Free

Applications

- Battery-Powered Equipments
- Graphic Card
- Peripheral Cards
- PCMCIA Card

Pin Configurations

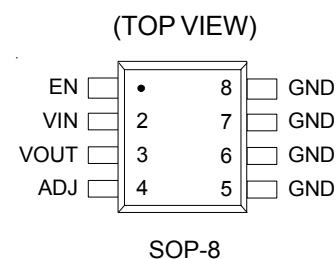

Functional Pin Description

Pin No.	Pin Name	Pin Function
2	VIN	Power Input Voltage
5, 6, 7, 8	GND	Ground
1	EN	Chip Enable (Active High)
4	ADJ	Adjust Output Voltage. The output voltage is set by the external feedback resistors connecting to ADJ pin and is calculated as : $V_{OUT} = 1.175 \times (1 + \frac{R_1}{R_2})$ Volts
3	VOUT	Output Voltage

Function Block Diagram

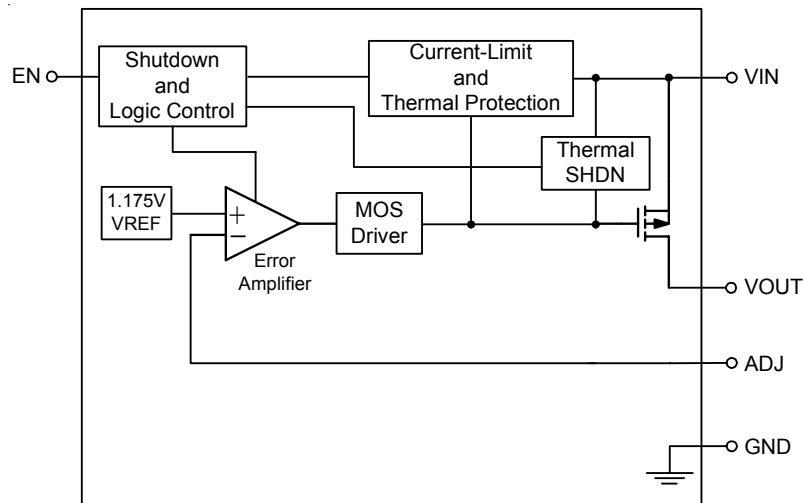

Absolute Maximum Ratings (Note 1)

- Supply Input Voltage ----- 6V
- Power Dissipation, P_D @ $T_A = 25^\circ\text{C}$, $T_J = 125^\circ\text{C}$
 SOP-8 ----- 1.67W
- Package Thermal Resistance (Note 2)
 SOP-8, θ_{JA} ----- 60°C/W
- Lead Temperature (Soldering, 10 sec.) ----- 260°C
- Junction Temperature ----- 150°C
- Storage Temperature Range ----- -65°C to 150°C
- ESD Susceptibility (Note 3)
 HBM (Human Body Mode) ----- 2kV
 MM (Machine Mode) ----- 200V

Recommended Operating Conditions (Note 4)

- Supply Input Voltage ----- 3V to 5.5V
- Enable Input Voltage ----- 0V to 5.5V
- Junction Temperature Range ----- -40°C to 125°C

Electrical Characteristics

($V_{IN} = V_{OUT} + 0.7\text{V}$, $I_{OUT} = 10\mu\text{A}$, $C_{IN} = 1\mu\text{F}$, $C_{OUT} = 3.3\mu\text{F}$ (Ceramic), $T_A = 25^\circ\text{C}$ unless otherwise specified)

Parameter	Symbol	Test Conditions	Min	Typ	Max	Unit	
Reference Voltage Tolerance	V_{REF}		1.163	1.175	1.187	V	
Adjust Pin Current	I_{ADJ}		--	--	10	nA	
Output Voltage Range	V_{OUT}		1.175	--	4.5	V	
Quiescent Current (Note 5)	I_Q	Enabled, $I_{OUT} = 0\text{mA}$	--	150	--	μA	
Standby Current (Note 6)	I_{STBY}	$V_{IN} = 5.5\text{V}$, Shutdown	--	--	1	μA	
Current Limit	I_{LIM}		700	--	--	mA	
Dropout Voltage (Note 7)	V_{DROP}	$I_{OUT} = 10\text{mA}$	--	10	--	mV	
		$I_{OUT} = 500\text{mA}$	--	400	--		
Line Regulation	ΔV_{LINE}	$V_{OUT} + 0.7\text{V} < V_{IN} < 5.5\text{V}$ & $3.3\text{V} < V_{IN} < 5.5\text{V}$	--	0.001	--	%/V	
Thermal Shutdown Temperature	T_{SD}		--	170	--	°C	
Thermal Shutdown Hysteresis	ΔT_{SD}		--	40	--	°C	
EN Threshold	Logic-Low Voltage	V_{IL}	$V_{IN} = 3.3\text{V}$, Shutdown	--	--	0.4	V
	Logic-High Voltage	V_{IH}	$V_{IN} = 3.3\text{V}$, Enable	2.0	--	--	
EN Current	I_{EN}	$V_{IN} = V_{CE} = 5.5\text{V}$	--	--	10	nA	

- Note 1.** Stresses listed as the above “Absolute Maximum Ratings” may cause permanent damage to the device. These are for stress ratings. Functional operation of the device at these or any other conditions beyond those indicated in the operational sections of the specifications is not implied. Exposure to absolute maximum rating conditions for extended periods may remain possibility to affect device reliability.
- Note 2.** θ_{JA} is measured in the natural convection at $T_A = 25^\circ\text{C}$ on the demo board, which has connected footprints as wide heat sink. Please see the thermal considerations on application information.
- Note 3.** Devices are ESD sensitive. Handling precaution recommended
- Note 4.** The device is not guaranteed to function outside its operating conditions.
- Note 5.** Quiescent, or ground current, is the difference between input and output currents. It is defined by $I_Q = I_{IN} - I_{OUT}$ under no load condition ($I_{OUT} = 0\text{mA}$). The total current drawn from the supply is the sum of the load current plus the ground pin current.
- Note 6.** Standby current is the input current drawn by a regulator when the output voltage is disabled by a shutdown signal ($V_{EN} \leq 0.4\text{V}$). It is measured with $V_{IN} = 5.5\text{V}$.
- Note 7.** The dropout voltage is defined as $V_{IN} - V_{OUT}$, which is measured when V_{OUT} is $V_{OUT(NORMAL)} - 100\text{mV}$.

Typical Operating Characteristics

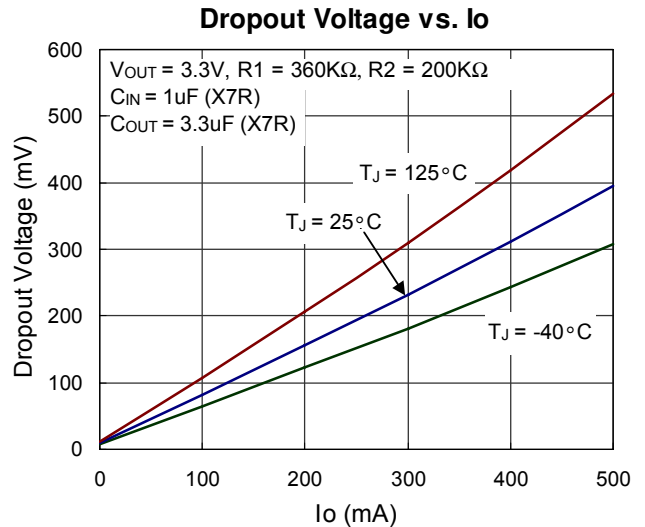
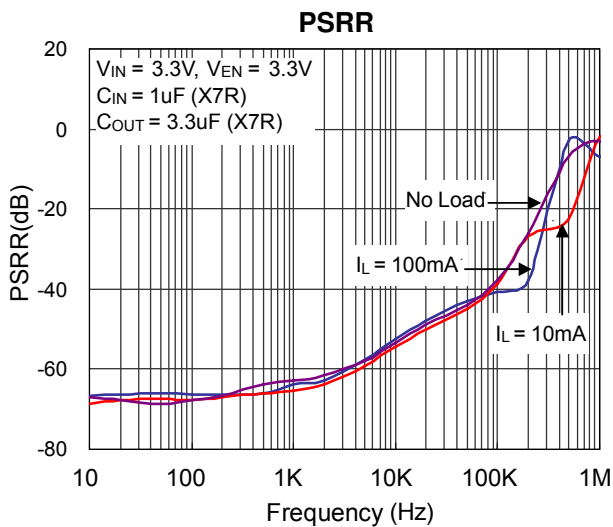
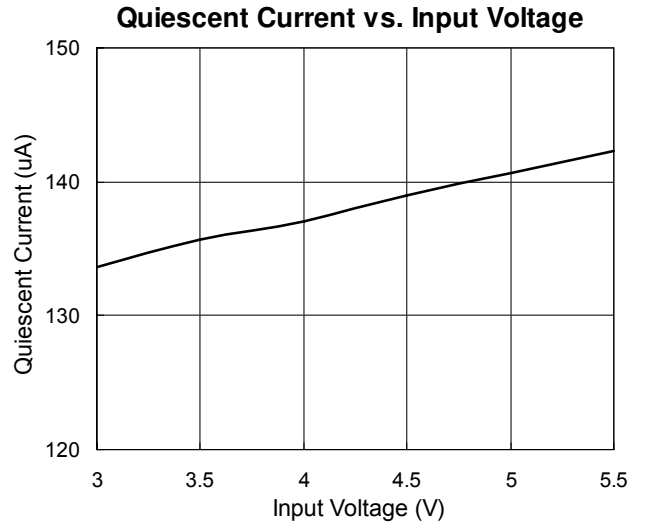
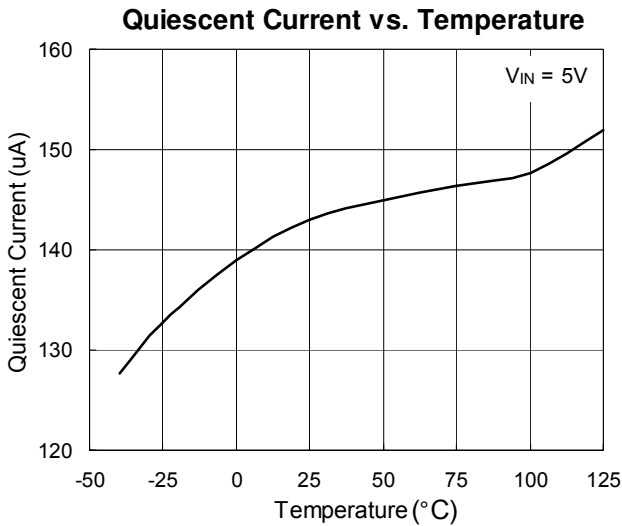
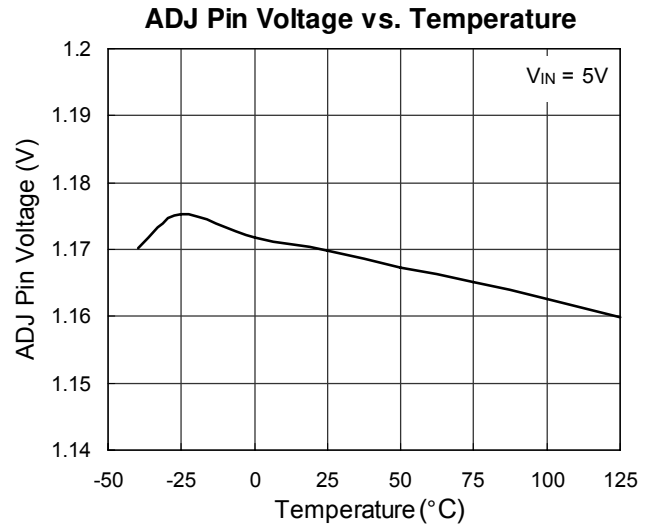
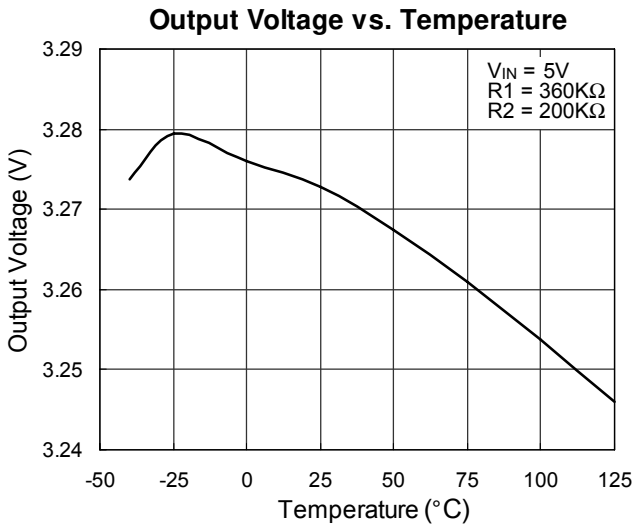

Current Limit vs. Temperature

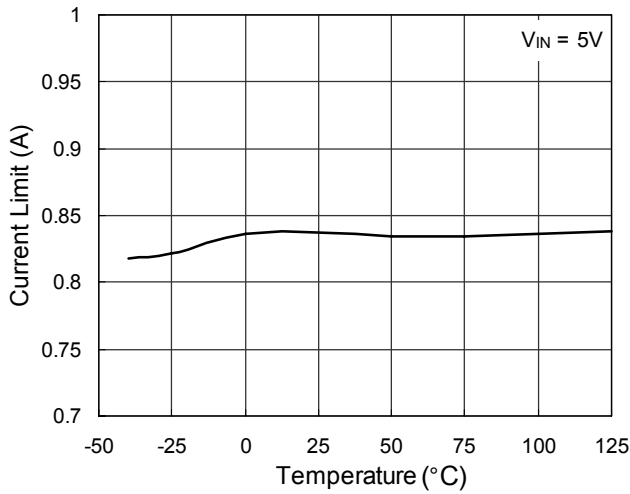

Output Short-Circuit Protection

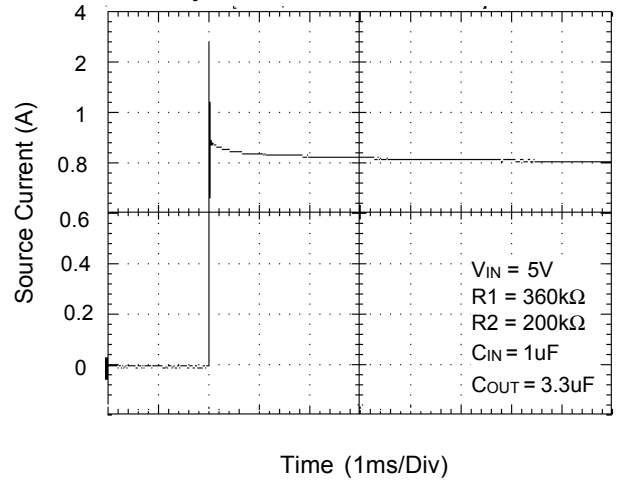

Line Transient Response

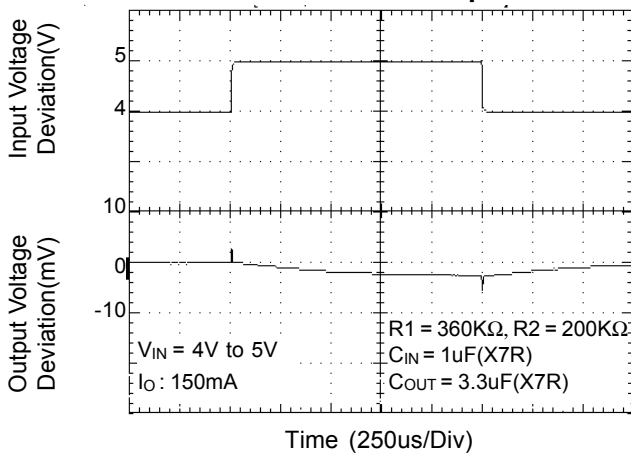

Load Transient Response

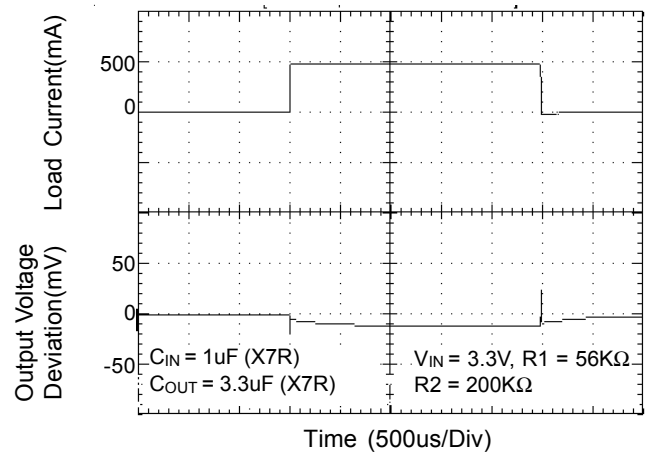

Enable Threshold Voltage vs. Temperature

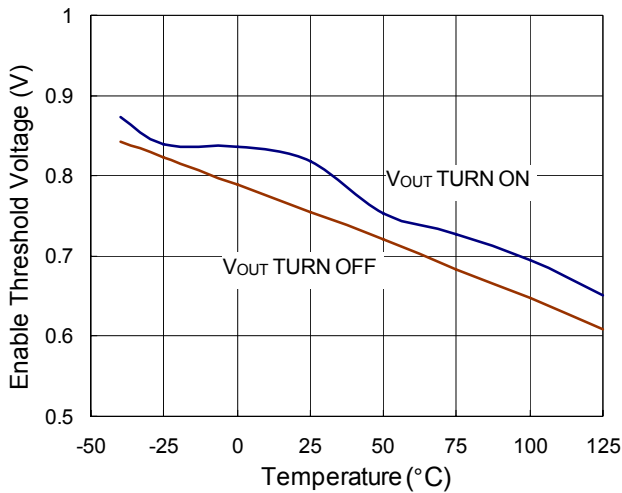

Enable Response

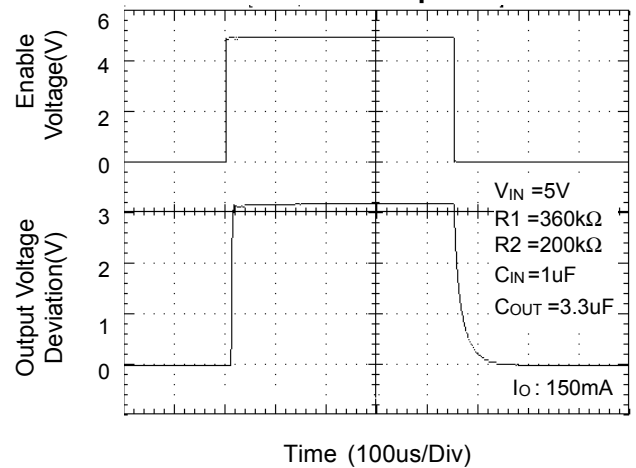

Application Information

Like any low-dropout regulator, the RT9179A requires input and output decoupling capacitors. These capacitors must be correctly selected for good performance (see Capacitor Characteristics Section). Please note that linear regulators with a low dropout voltage have high internal loop gains which require care in guarding against oscillation caused by insufficient decoupling capacitance.

Input Capacitor

An input capacitance of $\cong 1\mu\text{F}$ is required between the device input pin and ground directly (the amount of the capacitance may be increased without limit).

There are no requirements for the ESR on the input capacitor, but tolerance and temperature coefficient must be considered when selecting the capacitor to ensure the capacitance will be $\cong 1\mu\text{F}$ over the entire operating temperature range.

Output Capacitor

The RT9179A is designed specifically to work with very small ceramic output capacitors. The recommended minimum capacitance is $3.3\mu\text{F}$ ceramic or tantalum capacitor between LDO output and GND for stability. But for output voltage lower than 1.35V, to use a minimum of $3.3\mu\text{F}$ tantalum or electrolyte capacitor. Higher capacitance values help to improve transient. The output capacitor's ESR is critical because it forms a zero to provide phase lead which is required for loop stability.

No Load Stability

The device will remain stable and in regulation with no external load. This is specially important in CMOS RAM keep-alive applications

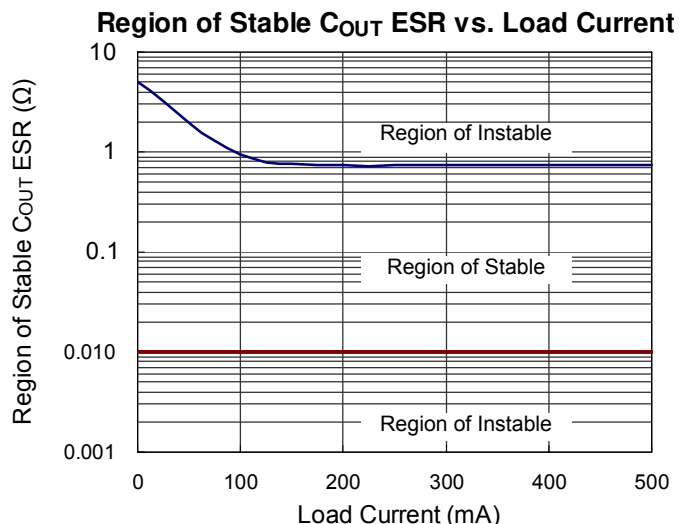

Input-Output (Dropout) Voltage

A regulator's minimum input-to-output voltage differential (dropout voltage) determines the lowest usable supply voltage. In battery-powered systems, this determines the useful end-of-life battery voltage. Because the device uses a PMOS, its dropout voltage is a function of drain-to-source on-resistance, $R_{\text{DS(ON)}}$, multiplied by the load current :

$$V_{\text{DROPOUT}} = V_{\text{IN}} - V_{\text{OUT}} = R_{\text{DS(ON)}} \times I_{\text{OUT}}$$

Current Limit

The RT9179A monitors and controls the PMOS' gate voltage, minimum limiting the output current to 700mA. The output can be shorted to ground for an indefinite period of time without damaging the part.

Short-Circuit Protection

The device is short circuit protected and in the event of a peak over-current condition, the short-circuit control loop will rapidly drive the output PMOS pass element off. Once the power pass element shuts down, the control loop will rapidly cycle the output on and off until the average power dissipation causes the thermal shutdown circuit to respond to servo the on/off cycling to a lower frequency. Please refer to the section on thermal information for power dissipation calculations.

Capacitor Characteristics

It is important to note that capacitance tolerance and variation with temperature must be taken into consideration when selecting a capacitor so that the minimum required amount of capacitance is provided over the full operating temperature range. In general, a good tantalum capacitor will show very little capacitance variation with temperature, but a ceramic may not be as good (depending on dielectric type).

Aluminum electrolytics also typically have large temperature variation of capacitance value.

Equally important to consider is a capacitor's ESR change with temperature: this is not an issue with ceramics, as their ESR is extremely low. However, it is very important in Tantalum and aluminum electrolytic capacitors. Both show increasing ESR at colder temperatures, but the increase in aluminum electrolytic capacitors is so severe they may not be feasible for some applications.

Ceramic :

For values of capacitance in the 10 μ F to 100 μ F range, ceramics are usually larger and more costly than tantalums but give superior AC performance for by-passing high frequency noise because of very low ESR (typically less than 10m Ω). However, some dielectric types do not have good capacitance characteristics as a function of voltage and temperature.

Z5U and Y5V dielectric ceramics have capacitance that drops severely with applied voltage. A typical Z5U or Y5V capacitor can lose 60% of its rated capacitance with half of the rated voltage applied to it. The Z5U and Y5V also exhibit a severe temperature effect, losing more than 50% of nominal capacitance at high and low limits of the temperature range.

X7R and X5R dielectric ceramic capacitors are strongly recommended if ceramics are used, as they typically maintain a capacitance range within $\pm 20\%$ of nominal over full operating ratings of temperature and voltage. Of course, they are typically larger and more costly than Z5U/Y5U types for a given voltage and capacitance.

Tantalum :

Solid tantalum capacitors are recommended for use on the output because their typical ESR is very close to the ideal value required for loop compensation. They also work well as input capacitors if selected to meet the ESR requirements previously listed.

Tantalums also have good temperature stability: a good quality tantalum will typically show a capacitance value that varies less than 10 to 15% across the full temperature range of 125°C to -40°C. ESR will vary only about 2X going from the high to low temperature limits.

The increasing ESR at lower temperatures can cause oscillations when marginal quality capacitors are used (if the ESR of the capacitor is near the upper limit of the stability range at room temperature).

Aluminum :

This capacitor type offers the most capacitance for the money. The disadvantages are that they are larger in physical size, not widely available in surface mount, and have poor AC performance (especially at higher frequencies) due to higher ESR and ESL.

Compared by size, the ESR of an aluminum electrolytic is higher than either Tantalum or ceramic, and it also varies greatly with temperature. A typical aluminum electrolytic can exhibit an ESR increase of as much as 50X when going from 25°C down to -40°C.

It should also be noted that many aluminum electrolytics only specify impedance at a frequency of 120Hz, which indicates they have poor high frequency performance. Only aluminum electrolytics that have an impedance specified at a higher frequency (between 20kHz and 100kHz) should be used for the device. Derating must be applied to the manufacturer's ESR specification, since it is typically only valid at room temperature.

Any applications using aluminum electrolytics should be thoroughly tested at the lowest ambient operating temperature where ESR is maximum.

Thermal Considerations

The RT9179A can deliver a current of up to 500mA over the full operating junction temperature range. However, the maximum output current must be derated at higher ambient temperature to ensure the junction temperature does not exceed 125°C. With all possible conditions, the junction temperature must be within the range specified under operating conditions. Power dissipation can be calculated based on the output current and the voltage drop across regulator.

$$P_D = (V_{IN} - V_{OUT}) I_{OUT} + V_{IN} I_{GND}$$

The final operating junction temperature for any set of conditions can be estimated by the following thermal equation :

$$P_{D(MAX)} = (T_{J(MAX)} - T_A) / \theta_{JA}$$

Where $T_{J(MAX)}$ is the maximum junction temperature of the die (125°C) and T_A is the maximum ambient temperature. The junction to ambient thermal resistance (θ_{JA} is layout dependent) for SOP-8 package is 60°C/W at recommended minimum footprint. Visit our website in which “Recommended Footprints for Soldering Surface Mount Packages” for detail. More power can be dissipated if the maximum ambient temperature of the application is lower. Approaches for enhancing thermal performance is improving the power dissipation capability of the PCB design like cooper area increases.

Thermal protection limits power dissipation in RT9179A. When the operation junction temperature exceeds 170°C, starts the thermal shutdown function and turns the pass element off. The pass element turns on again after the junction temperature reduced about 40°C.

PCB Layout

Good board layout practices must be used or instability can be induced because of ground loops and voltage drops. The input and output capacitors **MUST** be directly connected to the input, output, and ground pins of the device using traces which have no other currents flowing through them.

The best way to do this is to layout C_{IN} and C_{OUT} near the device with short traces to the V_{IN} , V_{OUT} , and ground pins. The regulator ground pin should be connected to the external circuit ground so that the regulator and its capacitors have a “single point ground” .

It should be noted that stability problems have been seen in applications where “vias” to an internal ground plane were used at the ground points of the device and the input and output capacitors. This was caused by varying ground potentials at these nodes resulting from current flowing through the ground plane.

Using a single point ground technique for the regulator and it's capacitors fixed the problem. Since high current flows through the traces going into V_{IN} and coming from V_{OUT} , Kelvin connect the capacitor leads to these pins so there is no voltage drop in series with the input and output capacitors.

Optimum performance can only be achieved when the device is mounted on a PC board according to the diagram below:

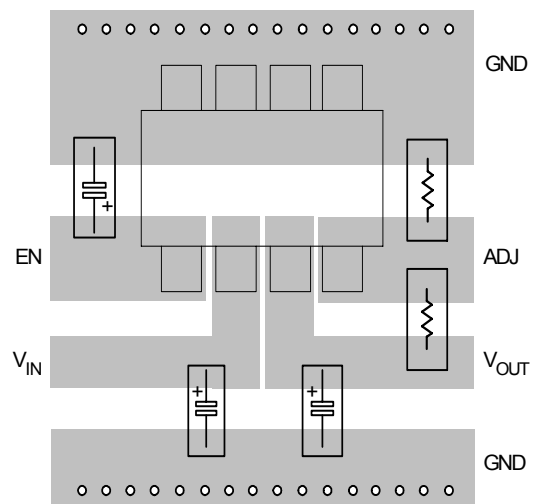

SOP-8 Board Layout

The RT9179ACS regulator is packaged in SOP-8 package. This package is unable to efficiently dissipate the heat generated when the regulator is operating at high power levels. In order to control die-operating temperatures, the PCB layout should allow for maximum possible copper area at the GND pins of the RT9179ACS. The multiple GND pins on the SOP-8 package are internally connected, but lowest thermal resistance will result if these pins are tightly connected on the PCB. This will also aid heat dissipation at high power levels. If the large copper around the IC is unavailable, a buried layer may be used as a heat sink. Use vias to conduct the heat into the buried or backside of PCB layer.

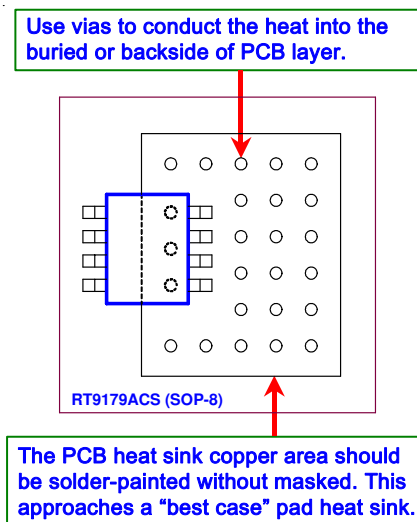

To prevent this maximum junction temperature from being exceeded, the appropriate power plane heat sink *MUST* be used. Higher continuous currents or ambient temperature require additional heatsinking.

Outline Dimension

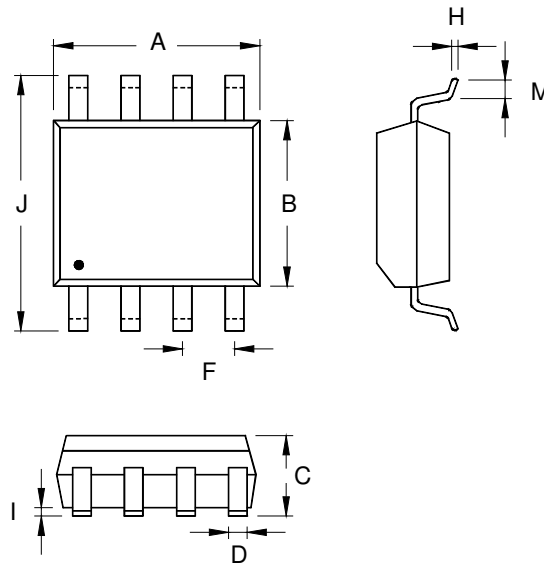

Symbol	Dimensions In Millimeters		Dimensions In Inches	
	Min	Max	Min	Max
A	4.801	5.004	0.189	0.197
B	3.810	3.988	0.150	0.157
C	1.346	1.753	0.053	0.069
D	0.330	0.508	0.013	0.020
F	1.194	1.346	0.047	0.053
H	0.170	0.254	0.007	0.010
I	0.050	0.254	0.002	0.010
J	5.791	6.200	0.228	0.244
M	0.400	1.270	0.016	0.050

8-Lead SOP Plastic Package

Richtek Technology Corporation

Headquarter
 5F, No. 20, Taiyuen Street, Chupei City
 Hsinchu, Taiwan, R.O.C.
 Tel: (8863)5526789 Fax: (8863)5526611

Richtek Technology Corporation

Taipei Office (Marketing)
 5F, No. 95, Minchiuan Road, Hsintien City
 Taipei County, Taiwan, R.O.C.
 Tel: (8862)86672399 Fax: (8862)86672377
 Email: marketing@richtek.com

Information that is provided by Richtek Technology Corporation is believed to be accurate and reliable. Richtek reserves the right to make any change in circuit design, specification or other related things if necessary without notice at any time. No third party intellectual property infringement of the applications should be guaranteed by users when integrating Richtek products into any application. No legal responsibility for any said applications is assumed by Richtek.