

LOC	DIST	REVISIONS			
P	LTR	DESCRIPTION	DATE	DWN	APVD
FI	25				
	C	REDWN & ADD: -5; NPR C96-153 & FC 0N20-0013-96	10JUL96	GG	NJ

1. WIDTH - 3/4 INCH
2. THICKNESS - .007 INCH
3. VOLTAGE RATING - 600 VRMS
4. TEMPERATURE RATING - 80°C
5. SHIPPING WEIGHT 84.2 GRAMS / 3 oz.
6. PVC FLAME RETARDED BLACK.

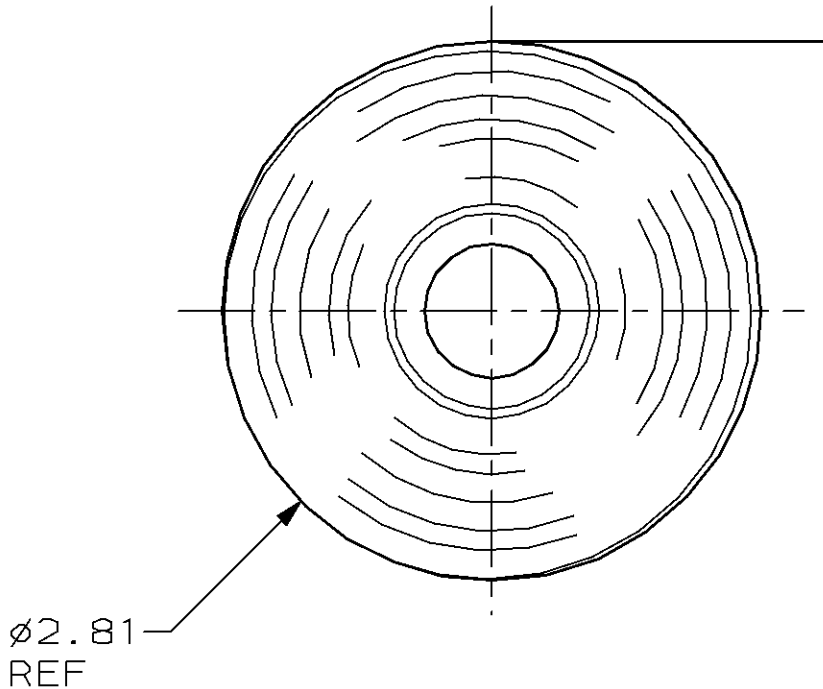

20 FT.	BULK PACKED INDIVIDUAL ROLLS	604271-5
66 FT.	10 ROLLS PER SLEEVE INDIVIDUALLY WRAPPED	604271-2
LENGTH	DESCRIPTION	PART NO.

RELEASED FOR PUBLICATION

THIS DRAWING IS UNPUBLISHED.

BY AMP INCORPORATED. ALL RIGHTS RESERVED.

DIMENSIONS: INCHES	
TOLERANCES UNLESS OTHERWISE SPECIFIED:	
0 PLC	±-
1 PLC	±-
2 PLC	±-
3 PLC	±-
4 PLC	±-
ANGLES	±-

DWN	G. GARRETT	10JUL96
CHK	N. JONES	15JUL96
APVD	E. HRYN	19JUL96
PRODUCT SPEC	-	
APPLICATION SPEC	-	
WEIGHT	-	
CUSTOMER DRAWING		

MATERIAL	△ 6		FINISH	-
AMP		AMP Incorporated Harrisburg, PA 17105-3608		
NAME TAPE, PVC ELECTRICAL BLACK				
SIZE	CAGE CODE	DRAWING NO		
A4	00779	C-604271		
SCALE	1:1	SHEET	1 OF 1	REV C