

NOTES:

1. MATERIALS AND FINISHES:  
 BODY & INNER BODY - BRASS, WHITE BRONZE PLATING  
 CONTACT - BeCu, GOLD PLATING  
 INSULATOR & INSULATOR DISC - PTFE, NATURAL  
 FERRULE - COPPER, WHITE BRONZE PLATING  
 HEAT SHRINK TUBE - CROSSLINKED POLYOLEFIN, BLACK
2. ELECTRICAL:  
 A. IMPEDANCE: 50 OHM  
 B. FREQUENCY RANGE: DC - 6 GHz  
 C. DIELECTRIC WITHSTANDING VOLTAGE: 1000 VRMS, MIN.
3. MECHANICAL:  
 A. DURABILITY: 500 CYCLES MIN.  
 B. TEMPERATURE RANGE: -55°C TO +85°C
4. PACKAGING:  
 A. QUANTITY: SINGLE PACK  
 B. MARKING: BAG TO BE MARKED  
 "AMPHENOL RF, 82-6644, AND DATE CODE"
5. RECOMMENDED CABLE ASSEMBLY INSTRUCTIONS:  
 A. TRIM CABLE AS SHOWN.  
 B. SLIDE HEAT SHRINK TUBE, FERRULE AND INSULATOR DISC ONTO CABLE.  
 C. SOLDER CABLE CENTER CONDUCTOR TO CONTACT.  
 D. INSERT CABLE WITH FOIL ENTERING CONNECTOR AND BRAID OVER KNURL.  
 E. CRIMP FERRULE OVER BRAID WITH .429" HEX DIE  
 F. APPLY HEAT SHRINK TUBE OVER FERRULE.

6 SHOWS CABLE ENTRY DIMENSIONS.

THIRD ANGLE PROJ.

REVISIONS

REV	DESCRIPTION	DATE	ECO	APPR
A	RELEASE TO MFG.	16-Jun-17	04004	BMG

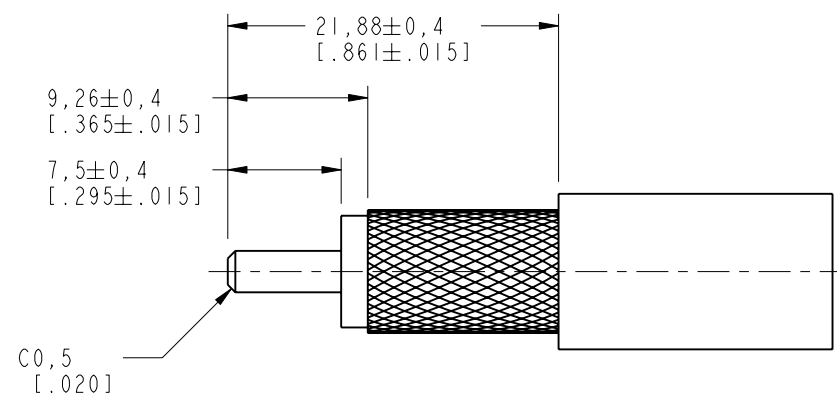

RECOMMENDED CABLE STRIPPING

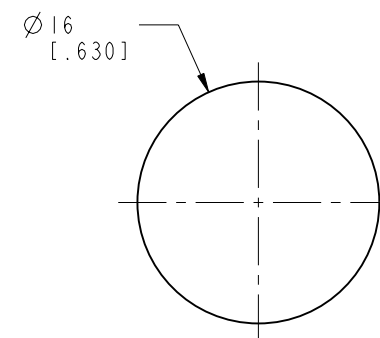

MIN PASS THRU DIAMETER

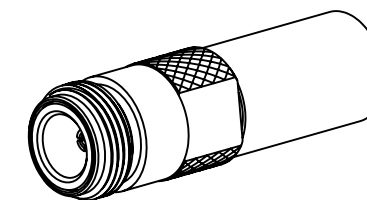

SCALE 1.000

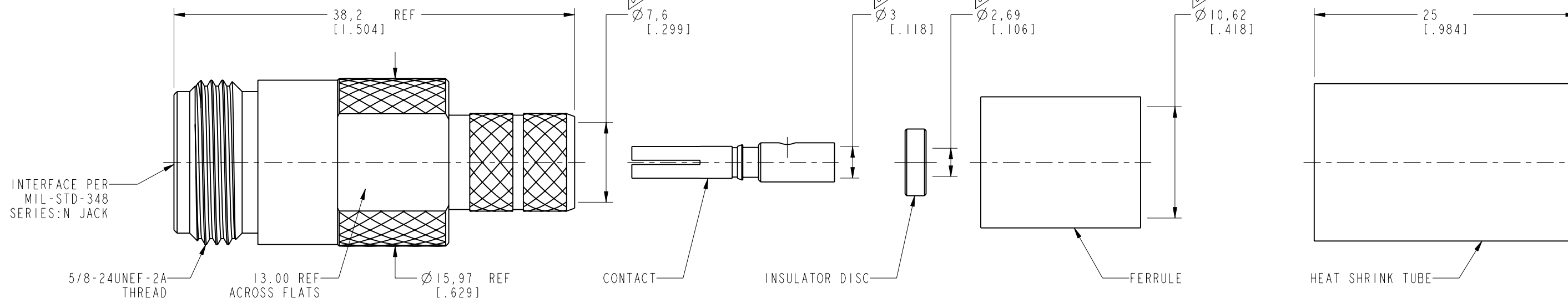

**CUSTOMER OUTLINE DRAWING**

ALL OTHER SHEETS ARE FOR INTERNAL USE ONLY

UNLESS OTHERWISE SPECIFIED, DIMENSIONS ARE IN METRIC AND TOLERANCES ARE: <0.5mm ±0.05mm    0.5 - 6mm ±0.1mm    6 - 30mm ±0.2mm    30 - 120mm ±0.3mm    ANGLES ±1°	MATERIAL	DRAWN	DATE	TITLE N STR JACK FOR LMR-400 CABLE		Amphenol RF www.amphenolrf.com	
	SEE NOTES	STAR	16-Jun-17				
NOTICE - These drawings, specifications, or other data (1) are, and remain the property of Amphenol corp. (2) must be returned upon request; and (3) are confidential and not to be disclosed to any person other than those to whom they are given by Amphenol Corp. the furnishing of these drawings, specifications, or other data by Amphenol Corp., or to any other person to anyone for any purpose is not to be regarded by implication or otherwise in any manner licensing, granting rights to permitting such holder or any other person to manufacture, use or sell any product, process or design, patented or otherwise, that may in any way be related to or disclosed by said drawings, specifications, or other data.	REFERENCE	ENGINEER	DATE	SCALE: 2.5:1.0    SHEET 2 OF 2		DRAWING NO. 82-6644 ITEM NO. 82-6644	
	EAR # 7407	SUNDE	16-Jun-17				
	CONFIGURATION LEVEL: In Work	APPROVED	DATE	REV	DWG SIZE    REV B    A		PART NO. 82-6644
FINISH	S. HSIEH	16-Jun-17	A				