

## Automotive-grade N-channel 60 V, 21 mΩ typ., 32 A STripFET™ F6 Power MOSFET in a PowerFLAT™ 5x6 package

Datasheet - production data

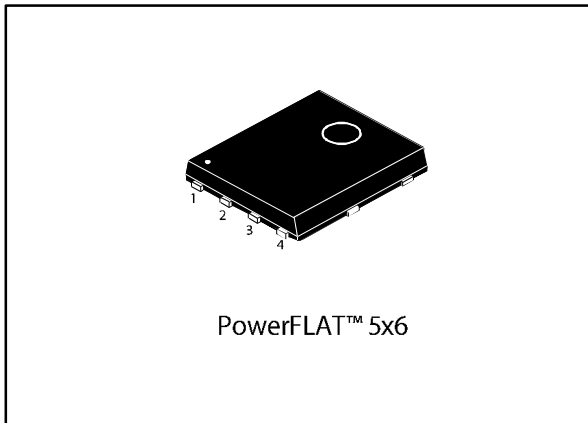
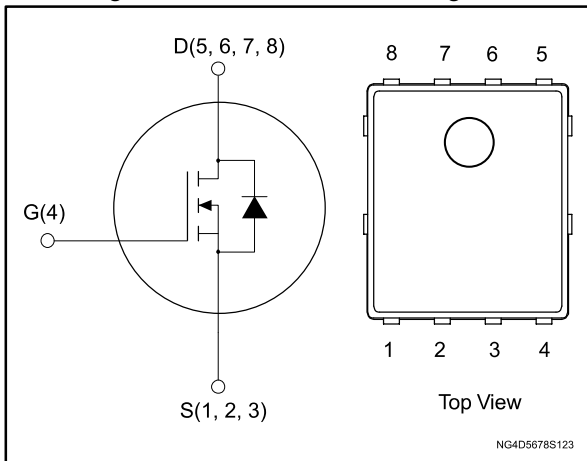

Figure 1: Internal schematic diagram



### Features

Order code	V <sub>DS</sub>	R <sub>DS(on)</sub> max.	I <sub>D</sub>	P <sub>TOT</sub>
STL8N6LF6AG	60 V	27 mΩ	32 A	55 W

- Designed for automotive applications and AEC-Q101 qualified
- Very low on-resistance
- Very low gate charge
- High avalanche ruggedness
- Low gate drive power loss
- Wettable flank package

### Applications

- Switching applications

### Description

This device is an N-channel Power MOSFET developed using the STripFET™ F6 technology with a new trench gate structure. The resulting Power MOSFET exhibits very low R<sub>DS(on)</sub> in all packages.

Table 1: Device summary

Order code	Marking	Package	Packing
STL8N6LF6AG	8N6LF6	PowerFLAT™ 5x6	Tape and reel

---

## Contents

<b>1</b>	<b>Electrical ratings .....</b>	<b>3</b>
<b>2</b>	<b>Electrical characteristics .....</b>	<b>4</b>
	2.1 Electrical characteristics (curves) .....	5
<b>3</b>	<b>Test circuits .....</b>	<b>7</b>
<b>4</b>	<b>Package information .....</b>	<b>8</b>
	4.1 PowerFLAT™ 5x6 WF type R package information .....	8
	4.2 PowerFLAT™ 5x6 WF packing information .....	11
<b>5</b>	<b>Revision history .....</b>	<b>13</b>

# 1 Electrical ratings

**Table 2: Absolute maximum ratings**

Symbol	Parameter	Value	Unit
$V_{DS}$	Drain-source voltage	60	V
$V_{GS}$	Gate-source voltage	±20	V
$I_D$	Drain current (continuous) at $T_{case} = 25\text{ °C}$	32	A
	Drain current (continuous) at $T_{case} = 100\text{ °C}$	23	
$I_D^{(1)}$	Drain current (continuous) at $T_{pcb} = 25\text{ °C}$	9.6	A
	Drain current (continuous) at $T_{pcb} = 100\text{ °C}$	6.8	
$I_{DM}^{(1)(2)}$	Drain current (pulsed)	38	A
$I_{DM}^{(2)}$	Drain current (pulsed)	128	A
$P_{TOT}$	Total dissipation at $T_{case} = 25\text{ °C}$	55	W
$P_{TOT}$	Total dissipation at $T_{pcb} = 25\text{ °C}$	4.8	
$T_{stg}$	Storage temperature	-55 to 175	°C
$T_j$	Operating junction temperature		

**Notes:**

(1) When mounted on a 1-inch<sup>2</sup> FR-4, 2 Oz copper board,  $t < 10\text{ s}$ .

(2) Pulse width is limited by safe operating area.

**Table 3: Thermal data**

Symbol	Parameter	Value	Unit
$R_{thj-case}$	Thermal resistance junction-case	2.7	°C/W
$R_{thj-pcb}^{(1)}$	Thermal resistance junction-pcb	31.3	

**Notes:**

(1) When mounted on a 1-inch<sup>2</sup> FR-4, 2 Oz copper board,  $t < 10\text{ s}$ .

**Table 4: Avalanche characteristics**

Symbol	Parameter	Value	Unit
$I_{AV}$	Avalanche current, not repetitive	32	A
$E_{AS}^{(1)}$	Single pulse avalanche energy	120	mJ

**Notes:**

(1) starting  $T_j = 25\text{ °C}$ ,  $I_D = I_{AV}$ ,  $V_{DD} = 43.5\text{ V}$ .

## 2 Electrical characteristics

( $T_{\text{case}} = 25\text{ °C}$  unless otherwise specified)

**Table 5: Static**

Symbol	Parameter	Test conditions	Min.	Typ.	Max.	Unit
$V_{(BR)DSS}$	Drain-source breakdown voltage	$V_{GS} = 0\text{ V}$ , $I_D = 250\text{ }\mu\text{A}$	60			V
$I_{DSS}$	Zero gate voltage drain current	$V_{GS} = 0\text{ V}$ , $V_{DS} = 60\text{ V}$			1	$\mu\text{A}$
$I_{GSS}$	Gate-body leakage current	$V_{DS} = 0\text{ V}$ , $V_{GS} = \pm 20\text{ V}$			$\pm 100$	nA
$V_{GS(th)}$	Gate threshold voltage	$V_{DS} = V_{GS}$ , $I_D = 250\text{ }\mu\text{A}$	1		2.5	V
$R_{DS(on)}$	Static drain-source on-resistance	$V_{GS} = 10\text{ V}$ , $I_D = 9.6\text{ A}$		21	27	m $\Omega$
		$V_{GS} = 4.5\text{ V}$ , $I_D = 9.6\text{ A}$		25	31	

**Table 6: Dynamic**

Symbol	Parameter	Test conditions	Min.	Typ.	Max.	Unit
$C_{iss}$	Input capacitance	$V_{DS} = 25\text{ V}$ , $f = 1\text{ MHz}$ , $V_{GS} = 0\text{ V}$	-	1340	-	pF
$C_{oss}$	Output capacitance		-	90	-	
$C_{riss}$	Reverse transfer capacitance		-	60	-	
$Q_g$	Total gate charge	$V_{DD} = 30\text{ V}$ , $I_D = 9.6\text{ A}$ , $V_{GS} = 10\text{ V}$ (see <a href="#">Figure 14</a> : "Test circuit for gate charge behavior")	-	27	-	nC
$Q_{gs}$	Gate-source charge		-	4.6	-	
$Q_{gd}$	Gate-drain charge		-	4.3	-	

**Table 7: Switching times**

Symbol	Parameter	Test conditions	Min.	Typ.	Max.	Unit
$t_{d(on)}$	Turn-on delay time	$V_{DD} = 30\text{ V}$ , $I_D = 12.5\text{ A}$ $R_G = 4.7\text{ }\Omega$ , $V_{GS} = 10\text{ V}$ (see <a href="#">Figure 13</a> : "Test circuit for resistive load switching times" and <a href="#">Figure 18</a> : "Switching time waveform")	-	9.6	-	ns
$t_r$	Rise time		-	20	-	
$t_{d(off)}$	Turn-off delay time		-	56	-	
$t_f$	Fall time		-	7	-	

**Table 8: Source-drain diode**

Symbol	Parameter	Test conditions	Min.	Typ.	Max.	Unit
$I_{SD}$	Source-drain current		-		9.6	A
$I_{SDM}^{(1)}$	Source-drain current (pulsed)		-		38	A
$V_{SD}^{(2)}$	Forward on voltage	$V_{GS} = 0\text{ V}$ , $I_{SD} = 9.6\text{ A}$	-		1.3	V
$t_{rr}$	Reverse recovery time	$I_{SD} = 25\text{ A}$ , $di/dt = 100\text{ A}/\mu\text{s}$ , $V_{DD} = 48\text{ V}$ (see <a href="#">Figure 15</a> : "Test circuit for inductive load switching and diode recovery times")	-	22.5		ns
$Q_{rr}$	Reverse recovery charge		-	22.2		nC
$I_{RRM}$	Reverse recovery current		-	2.0		A

**Notes:**

(1) Pulse width is limited by safe operating area.

(2) Pulse test: pulse duration = 300  $\mu\text{s}$ , duty cycle 1.5%.

## 2.1 Electrical characteristics (curves)

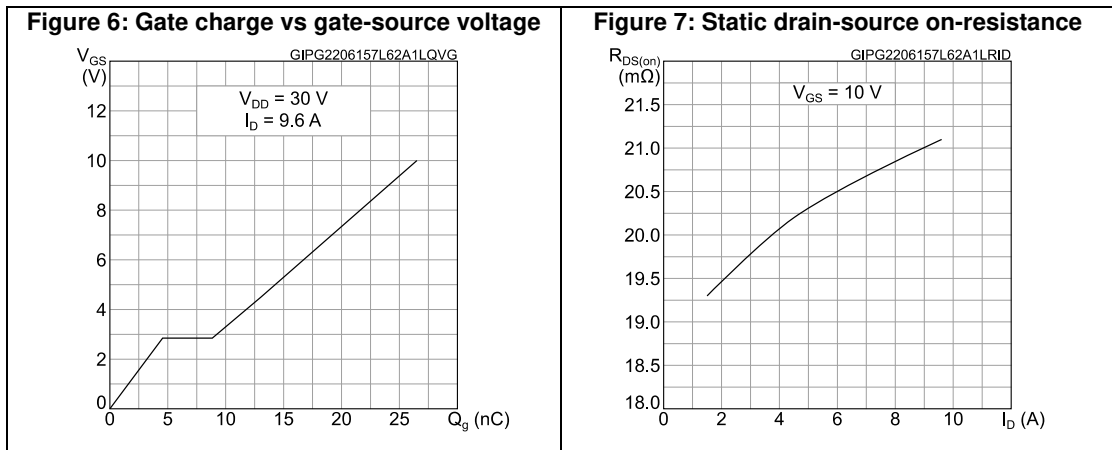
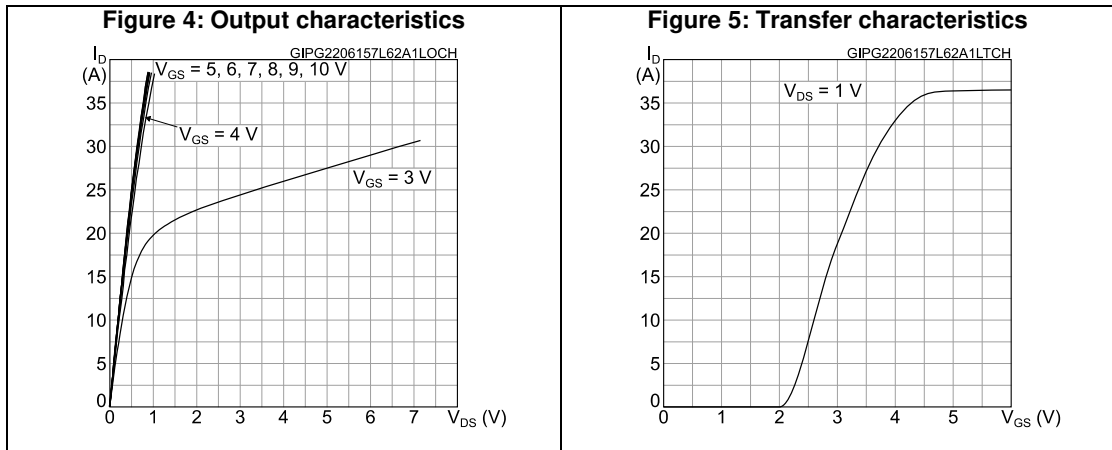
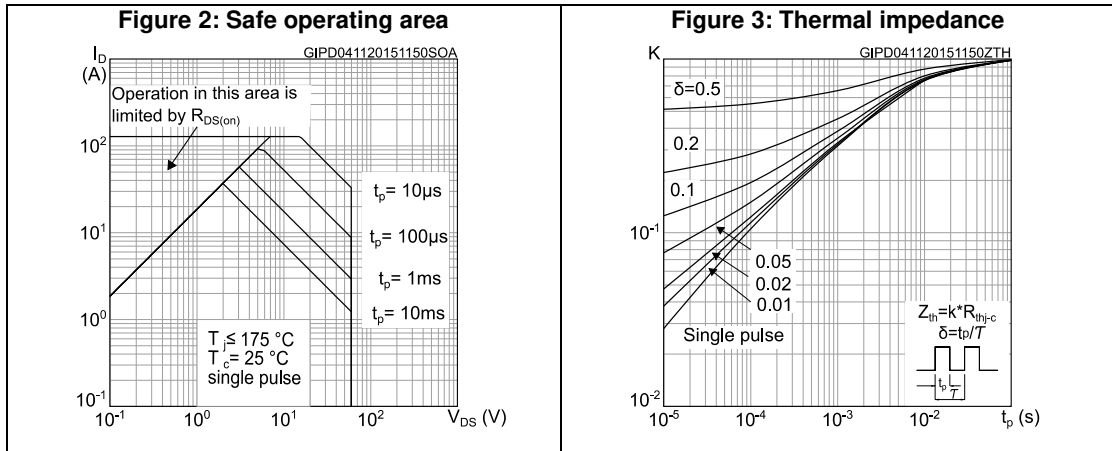

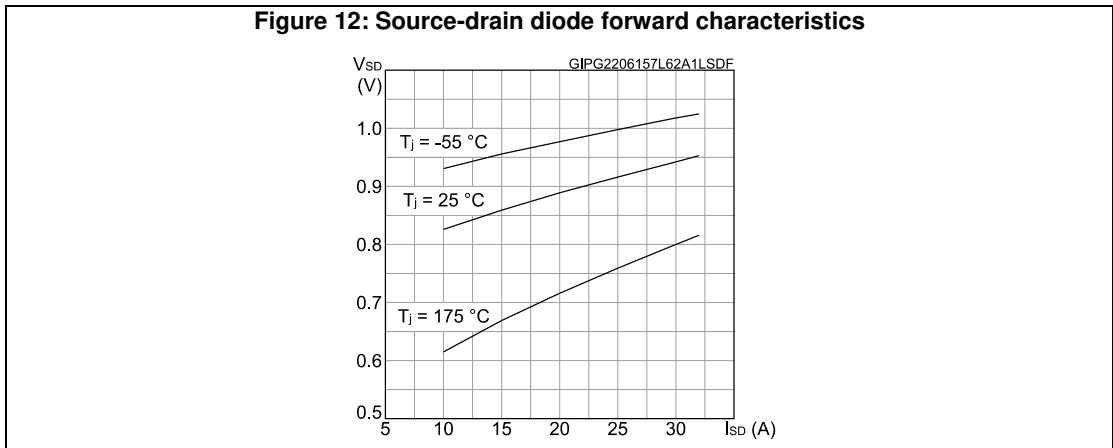
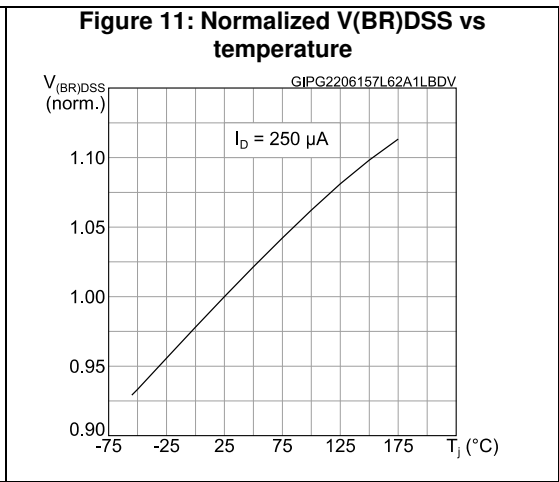
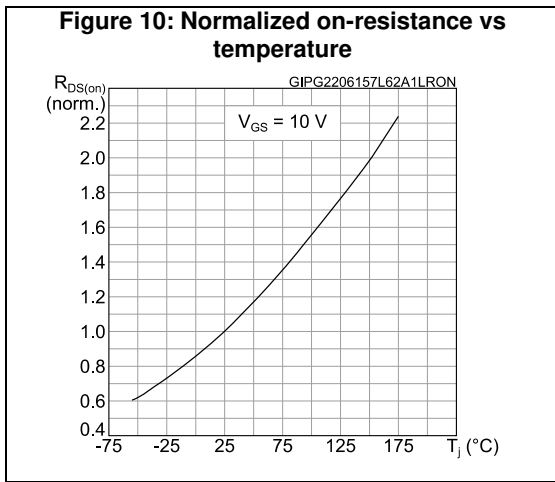
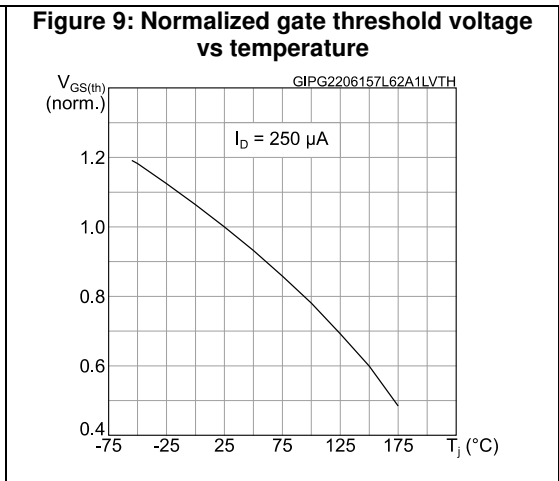
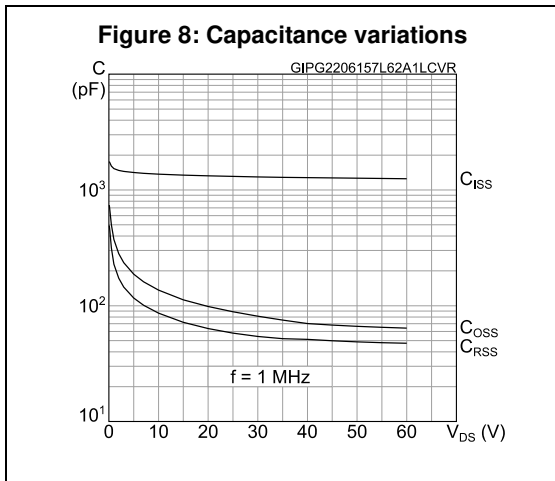

### 3 Test circuits

**Figure 13: Test circuit for resistive load switching times**

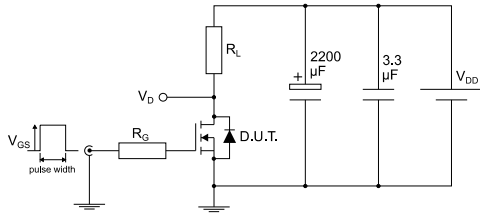

AM01468v1

**Figure 14: Test circuit for gate charge behavior**

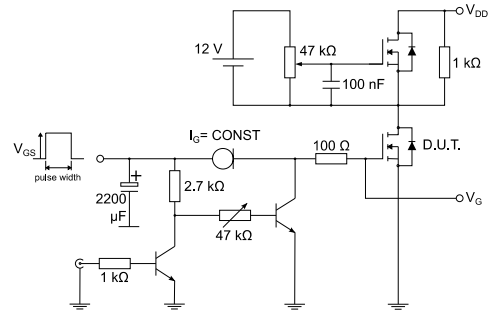

AM01469v1

**Figure 15: Test circuit for inductive load switching and diode recovery times**

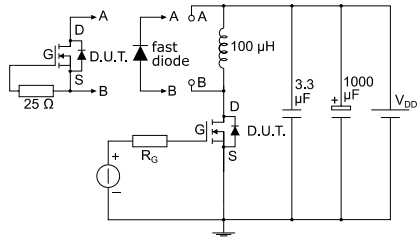

AM01470v1

**Figure 16: Unclamped inductive load test circuit**

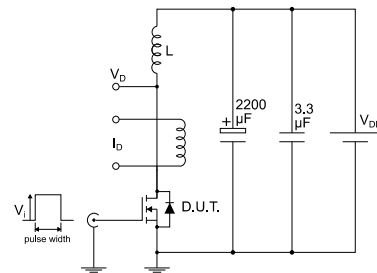

AM01471v1

**Figure 17: Unclamped inductive waveform**

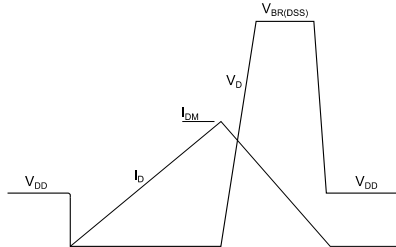

AM01472v1

**Figure 18: Switching time waveform**

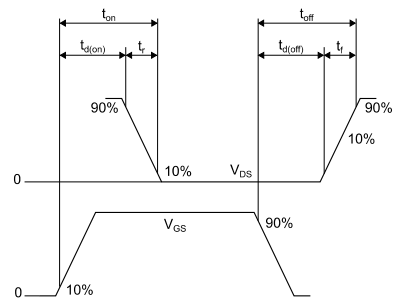

AM01473v1

## 4 Package information

In order to meet environmental requirements, ST offers these devices in different grades of ECOPACK® packages, depending on their level of environmental compliance. ECOPACK® specifications, grade definitions and product status are available at: [www.st.com](http://www.st.com). ECOPACK® is an ST trademark.

### 4.1 PowerFLAT™ 5x6 WF type R package information

Figure 19: PowerFLAT™ 5x6 WF type R package outline

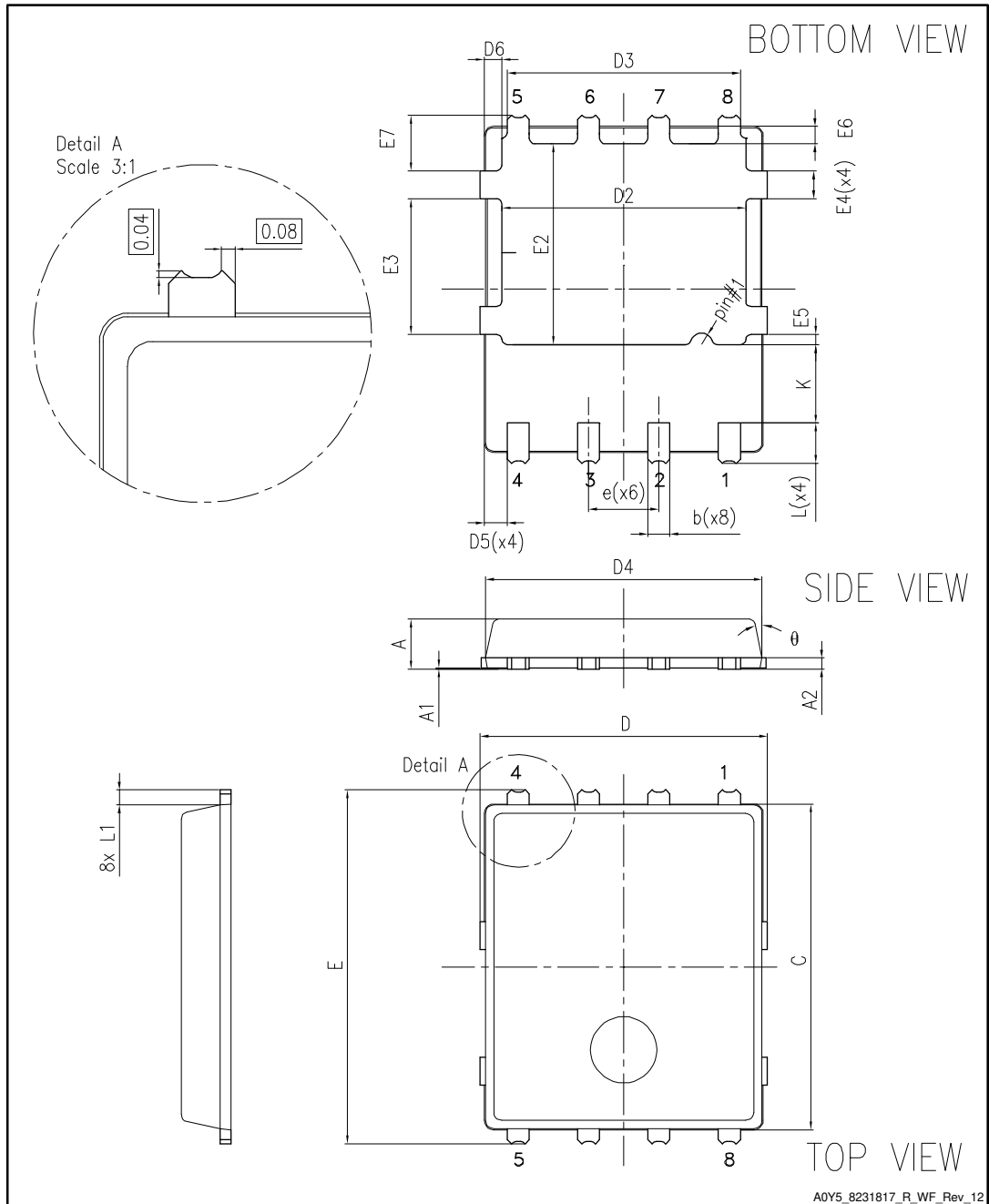



Table 9: PowerFLAT™ 5x6 WF type R mechanical data

Dim.	mm		
	Min.	Typ.	Max.
A	0.80		1.00
A1	0.02		0.05
A2		0.25	
b	0.30		0.50
C	5.80	6.00	6.20
D	5.00	5.20	5.40
D2	4.15		4.45
D3	4.05	4.20	4.35
D4	4.80	5.0	5.20
D5	0.25	0.4	0.55
D6	0.15	0.3	0.45
e		1.27	
E	6.20	6.40	6.60
E2	3.50		3.70
E3	2.35		2.55
E4	0.40		0.60
E5	0.08		0.28
E6	0.175	0.325	0.450
E7	0.85	1.00	1.15
K	1.275		1.575
L	0.725	0.825	0.925
L1	0.175	0.275	0.375
Θ	0°		12°

Figure 20: PowerFLAT™ 5x6 recommended footprint (dimensions are in mm)

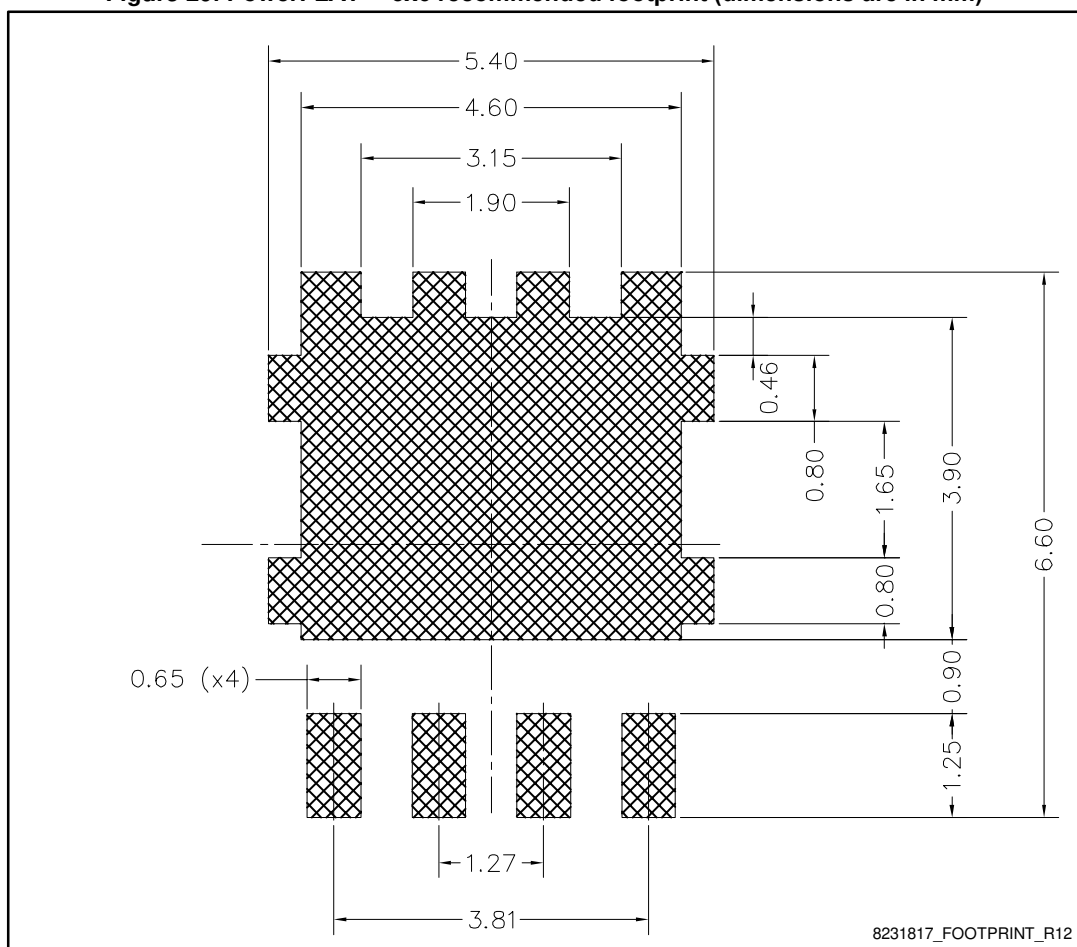
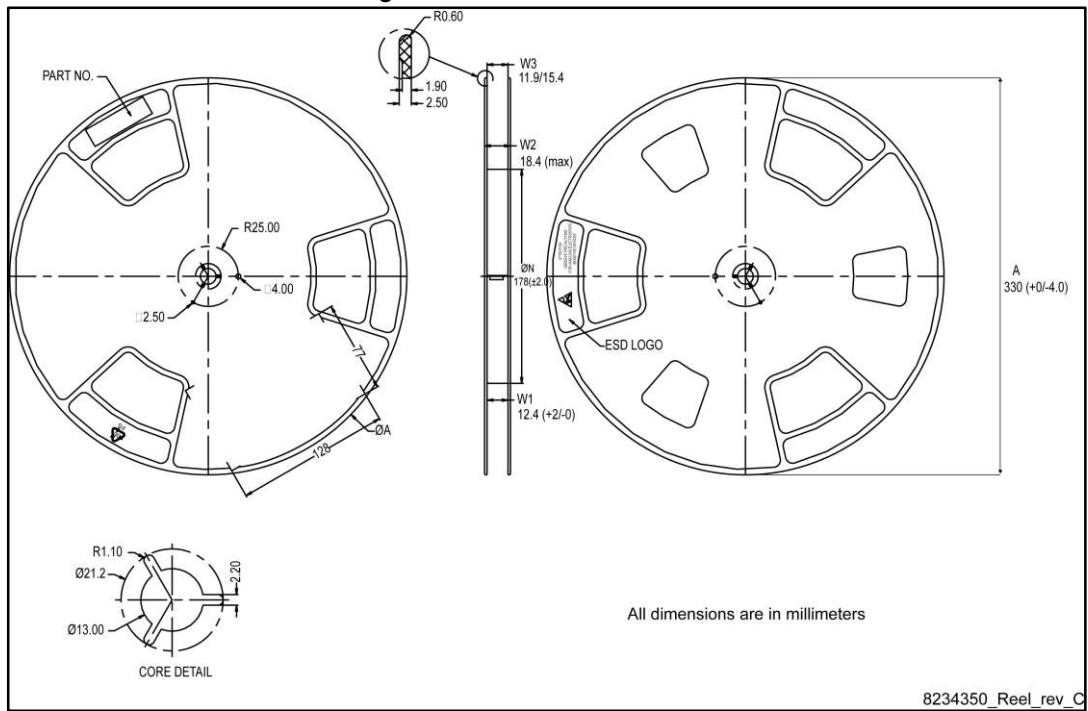



Figure 23: PowerFLAT™ 5x6 reel



## 5 Revision history

Table 10: Document revision history

Date	Revision	Changes
06-Jul-2015	1	First release.
07-Jan-2016	2	Updated title and features in cover page. Updated <i>Section 1: "Electrical ratings"</i> , <i>Section 2: "Electrical characteristics"</i> and <i>Section 4.1: "PowerFLAT™ 5x6 WF type R package information"</i> .

**IMPORTANT NOTICE – PLEASE READ CAREFULLY**

STMicroelectronics NV and its subsidiaries ("ST") reserve the right to make changes, corrections, enhancements, modifications, and improvements to ST products and/or to this document at any time without notice. Purchasers should obtain the latest relevant information on ST products before placing orders. ST products are sold pursuant to ST's terms and conditions of sale in place at the time of order acknowledgement.

Purchasers are solely responsible for the choice, selection, and use of ST products and ST assumes no liability for application assistance or the design of Purchasers' products.

No license, express or implied, to any intellectual property right is granted by ST herein.

Resale of ST products with provisions different from the information set forth herein shall void any warranty granted by ST for such product.

ST and the ST logo are trademarks of ST. All other product or service names are the property of their respective owners.

Information in this document supersedes and replaces information previously supplied in any prior versions of this document.

© 2016 STMicroelectronics – All rights reserved