

FAN8408D

2 Phase Half Wave BLDC Motor Driver

Features

- A wide range of operation voltage: 4V to 15V
- Built-in motor lock detector.
- Automatic restart function
- Hall output for a motor speed detection
- Built-in thermal shut down circuits
- Built-in reverse current protection diode
- Compact package: 8-SOP-225

Description

The FAN8408D is a monolithic integrated circuit, and suitable for DC cooling fan motors.

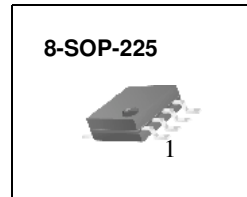

Typical Applications

- DC cooling fan motor

Ordering Information

Device	Package	Operating Temp.
FAN8408D	8-SOP-225	-25°C ~ 85°C
FAN8408DTF	8-SOP-225	-25°C ~ 85°C

Block Diagram

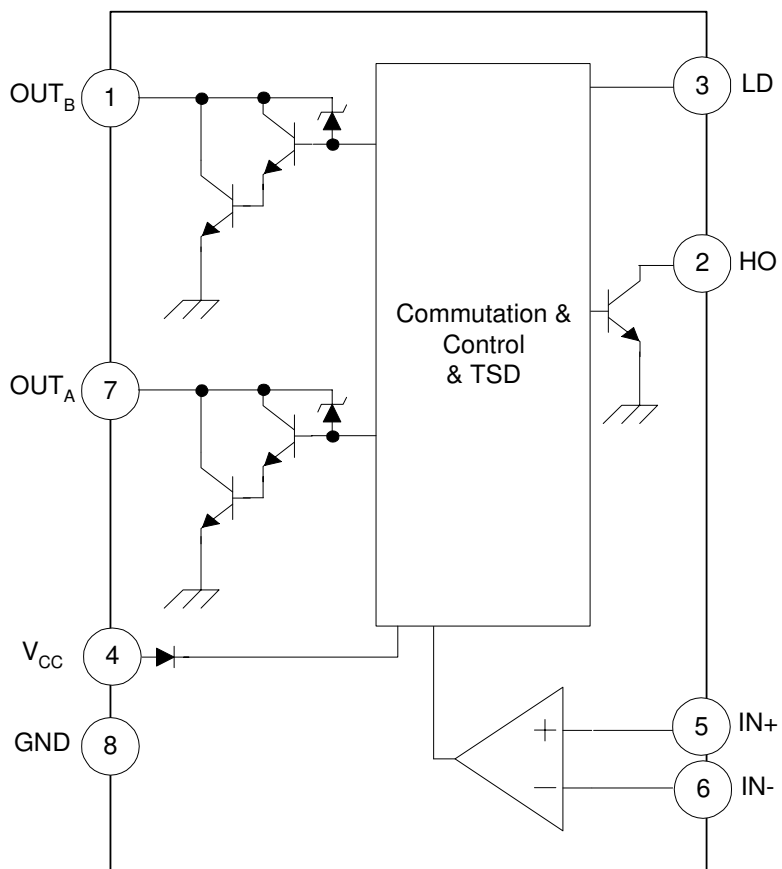

Pin Definitions

Pin Number	Pin Name	I/O	Pin Function Description	Remark
1	OUTB	O	Motor output B	-
2	HO	O	Hall output	Open Collector
3	LD	-	Triangle pulse generator for lock detector and automatic restart	-
4	VCC	-	Supply voltage	-
5	IN+	I	Hall input +	-
6	IN-	I	Hall input -	-
7	OUTA	O	Motor output A	-
8	GND	-	Ground	-

Equivalent Circuits

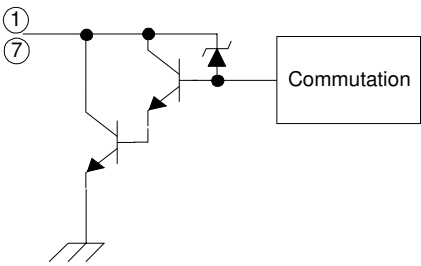
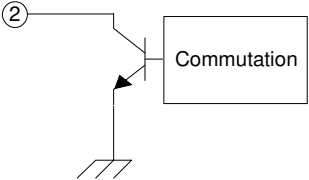
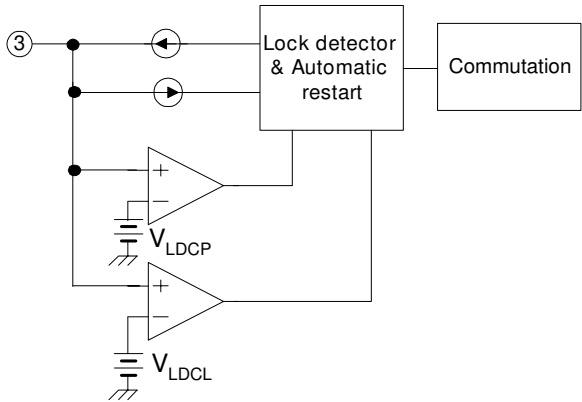
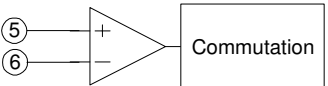
Description	Pin No.	Internal Circuit
OUTB	1	
OUTA	7	
HO	2	
LD	3	
IN+	5	
IN-	6	

Absolute Maximum Ratings (Ta = 25°C)

Parameter	Symbol	Value	Unit
Maximum power supply voltage	VCCMAX	18	V
Maximum power dissipation ^{note1}	PDMAX	429 ^{note2}	mW
		620 ^{note3}	
Thermal resistance ^{note1}	Θ_{JA}	291.61 ^{note2}	°C/W
		201.52 ^{note3}	
Maximum output voltage	VOMAX	30	V
Maximum output current	IOMAX	1.2 ^{note4}	A
Hall output current	IHO	10	mA
Hall output withstanding voltage	VHO	36	V
Maximum hall input ac level	VHACMAX	6	V
Operating temperature	TOPR	-25 ~ 85	°C
Storage temperature	TSTG	-55 ~ 150	°C

Note1:

PCB Condition: Thickness(1.6mm), Dimension(76.2mm * 114.3mm)

Refer: EIA/J SED 51-3 & EIA/J SED 51-7

Note2: Air condition (0m/s)

Note3: Air condition (3m/s)

Note4: Should not exceed P_D or ASO value

Power Dissipation Curve (Air condition = 0m/s)

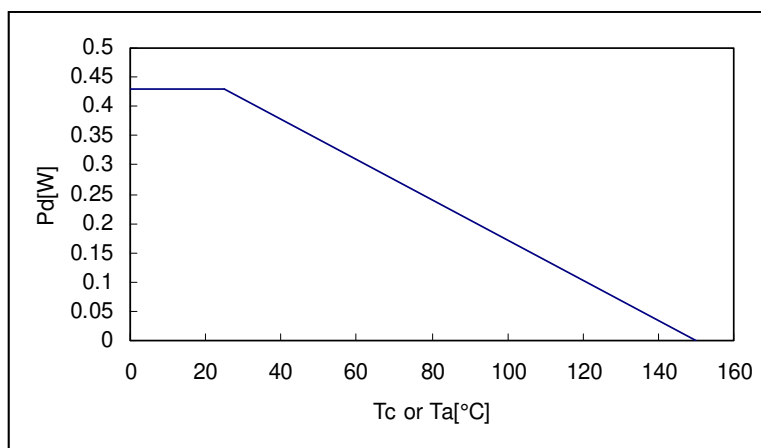

Air Speed & Θ_{JA}

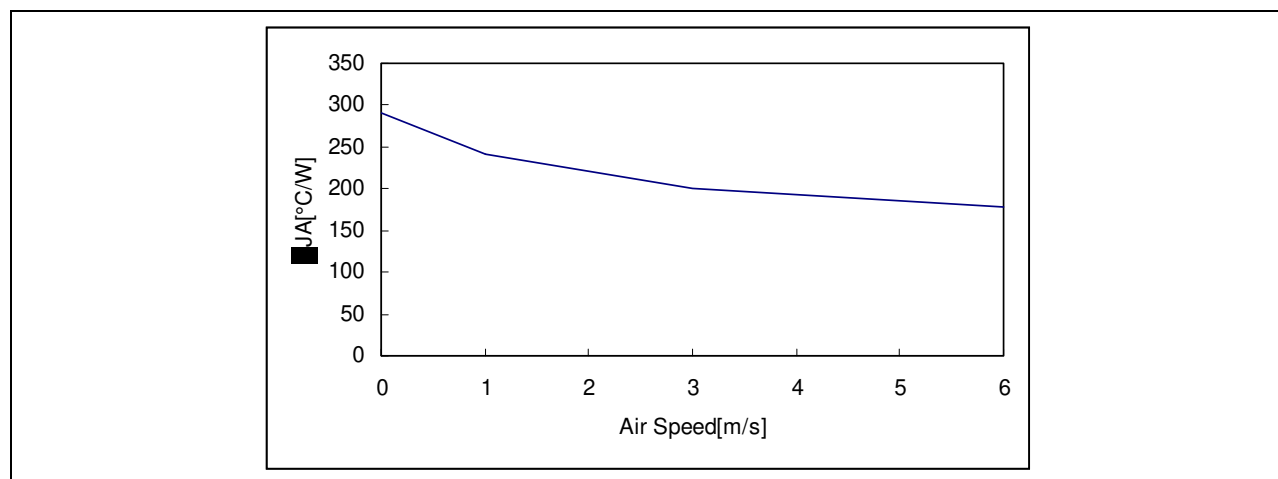

Recommended Operating Conditions (Ta = 25°C)

Parameter	Symbol	Min.	Typ.	Max.	Unit
Function compensation operating voltage	V _{CC}	4.0	–	15.0	V

Electrical Characteristics

(Ta=25°C, V_{CC}=12V unless otherwise specified)

Parameter	Symbol	Conditions	Min.	Typ.	Max.	Unit
Supply current	I _{CC}	When output is off.	-	-	3.0	mA
Lock detector charging current	I _{LDC}	V _{LD} =1.8V	2.38	3.40	4.42	μA
Lock detector discharging current	I _{LDD}	V _{LD} =1.8V	0.48	0.68	0.88	μA
Lock detector charging/discharging ratio	R _{CD}	R _{CD} =I _{LDC} /I _{LDD}	3.0	5.0	7.0	–
Lock detector capacitor clamp voltage	V _{LDCL}	-	2.4	2.85	3.3	V
Lock detector capacitor comparator voltage	V _{LDPC}	-	0.7	0.99	1.2	V
Output low level voltage	V _{OL}	I _O =200mA	-	0.9	1.2	V
Output leakage current	I _{OL}	-	-	0	10	μA
Output zener voltage	V _{OZ}	Clamp current=10mA	28	30	32	V
Hall output pin low level voltage	V _{HLL}	I _O =10mA	-	0.2	0.5	V
Hall output pin leakage current	I _{HLL}	-	-	0	10	μA
Hall input dc range	V _{HDC}	-	1	-	V _{CC} -2V	V
Hall input offset	V _{HOF}	V _{REF} =6V	-10	-	10	mV

Application Information

1. Lock Detection & Automatic Restart

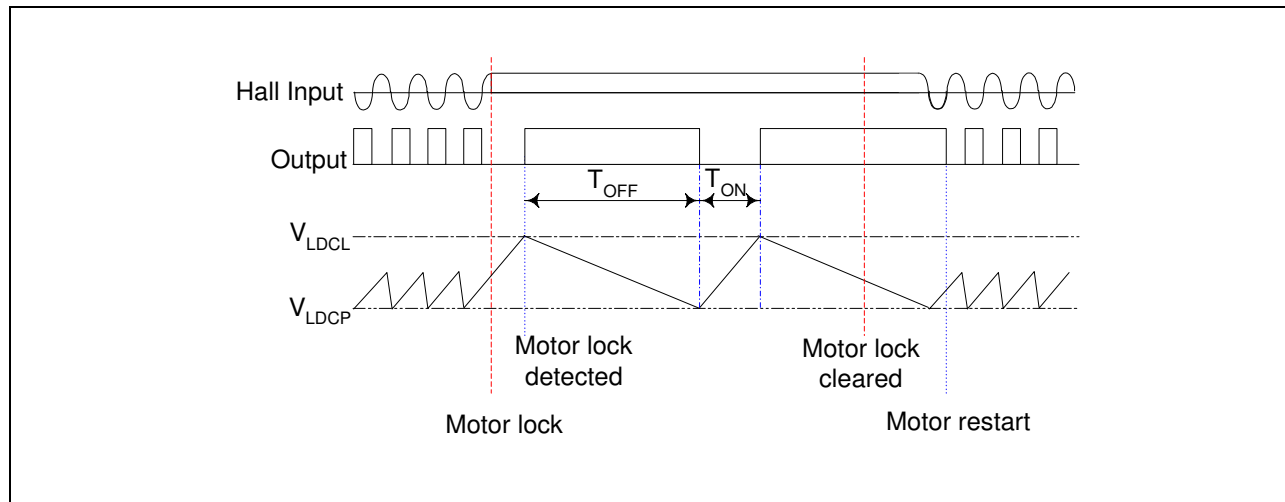

FAN8408D features a lock detection and an automatic restart. The functions can be operated as follows.

- 1) When the hall signal stop switching, a motor can be locked.
- 2) The voltage, VLD on pin 3, is increasing until it reaches VLDCL.
- 3) If LD pin is connected to GND, the lockup protection is disabled.
- 4) While a motor is locked, the output repeats switching ON / OFF, but the other output is always OFF. The switching time can be determined by an external capacitor on charging / discharging time of the capacitor, switching ON / OFF time can be calculated as follows.

$$T_{ON} = \frac{C_{LD} \times (V_{LDCL} - V_{LDCL})}{I_{LDC}}$$

$$T_{OFF} = \frac{C_{LD} \times (V_{LDCL} - V_{LDCL})}{I_{LDD}}$$

Where, The CLD is an external capacitor connected to pin 3, LD.

The VLDCL is the clamp voltage on pin 3, LD.

The VLDCL is the comparator voltage on pin 3, LD.

The ILDC is the charging current on pin 3, LD.

The ILDD is the discharging current on pin 3, LD.

2. Thermal Shut Down

TSD On: All the outputs are off. (Typ. 175°C)

TSD Off: The circuit can be reactivated and begin to operate in a normal condition. (Typ. 150°C)

3. Hall Amplifier Input Block

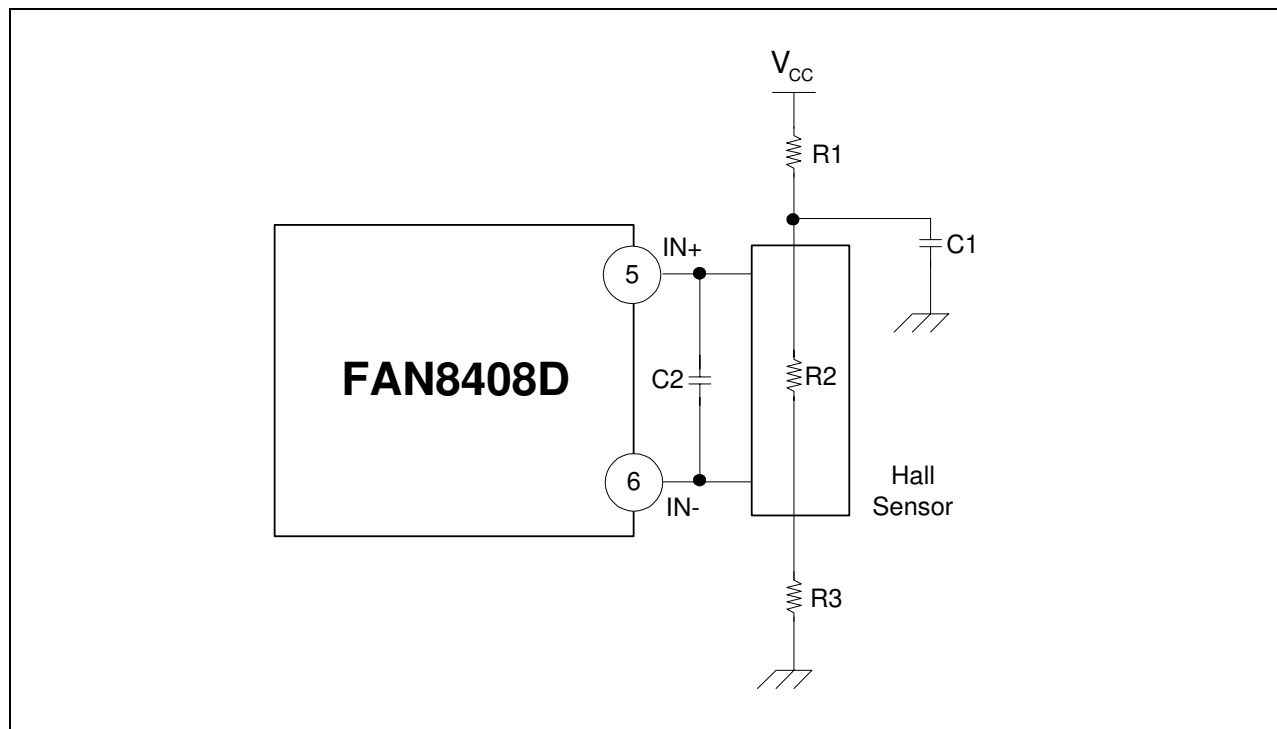

The hall current (I_H) is determined by R1, R2 and R3.

$$I_H = \frac{V_{CC}}{R1 + R2 + R3}$$

Where, the R2 is the impedance of hall sensor.

An external capacitor, C1, can be used to reduce a power supply noise. In addition, C2 is to remove a noise which is caused in case the line is long from the hall sensor output to the hall input (pin 5 / 6) of the device.

The input bias voltage of hall amplifier is between 1V and $V_{CC}-2V$ as following figure.

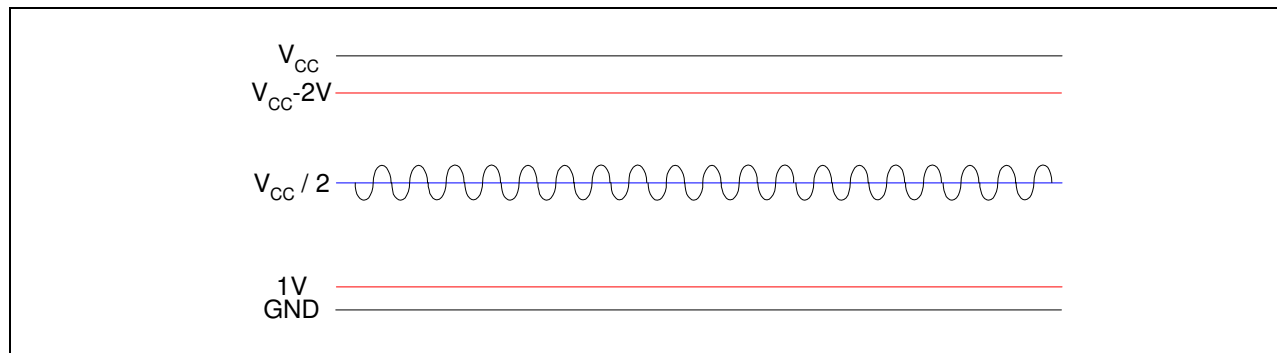

It is recommended that R1 and R3 should have the same value to make the output signal of hall sensor centered as $V_{CC}/2$.

Operation Truth Table

IN+	IN-	OUTA	OUTB	HO
High	Low	High	Low	Low
Low	High	Low	High	High

Test Circuits

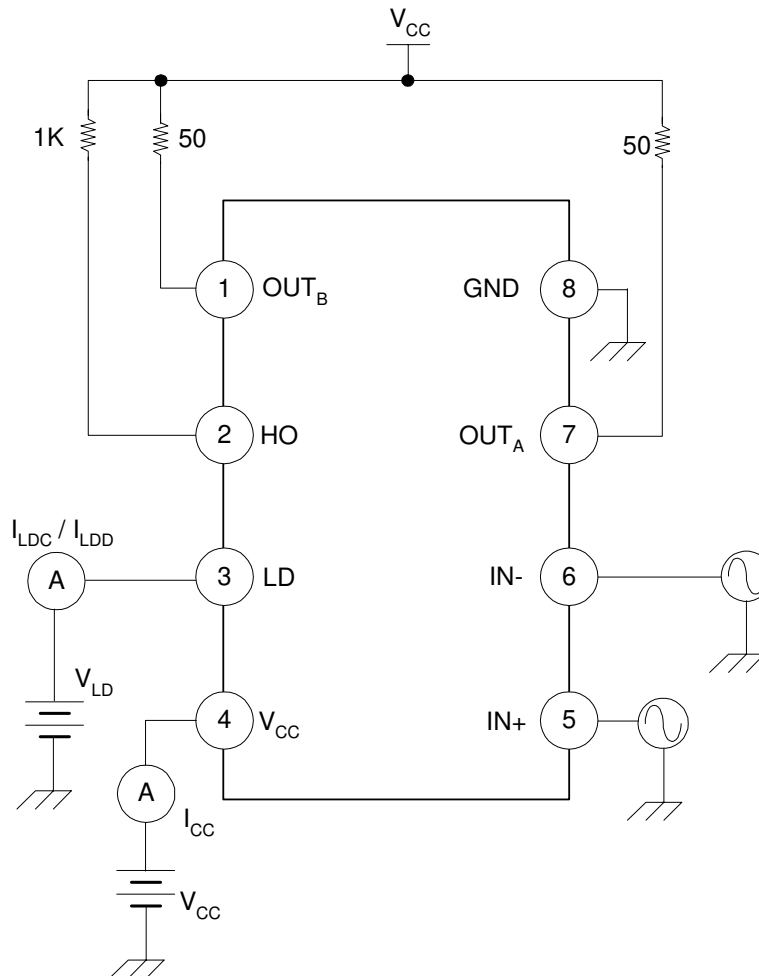

Typical Application Circuits

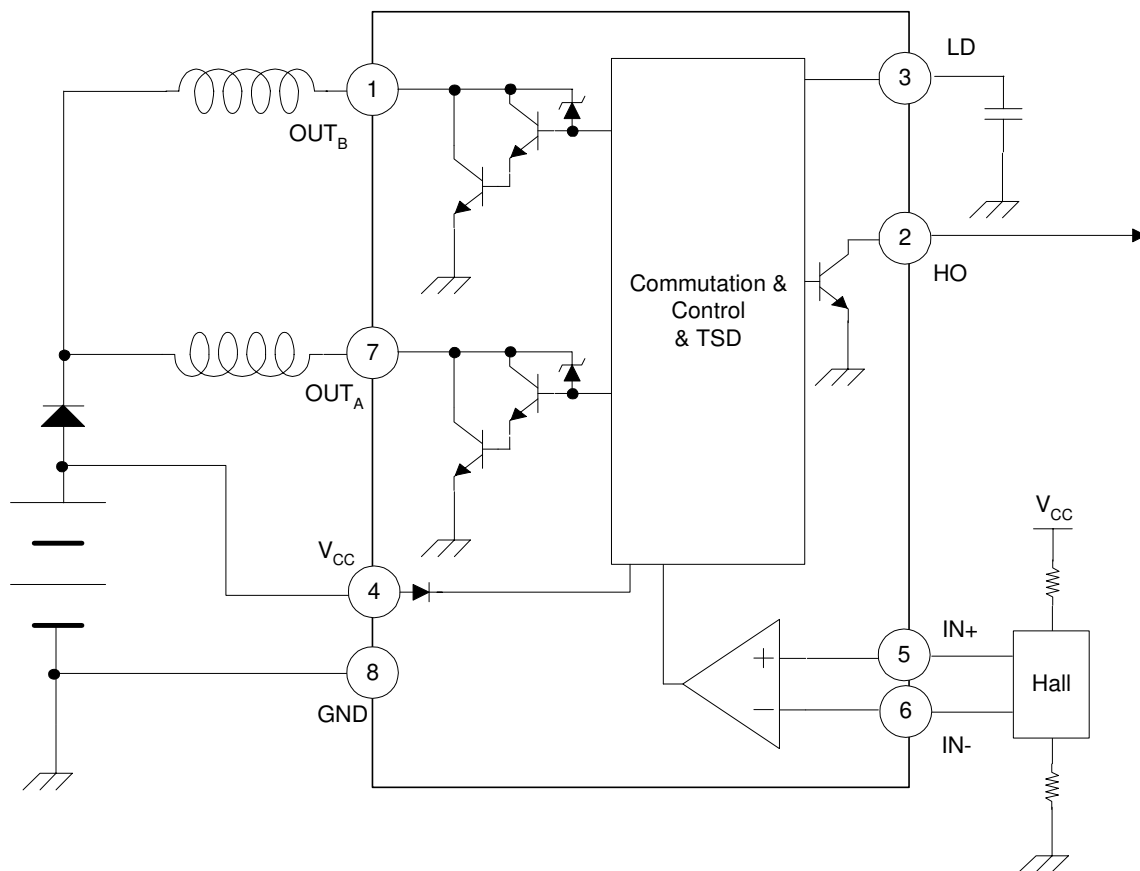

Precaution

In case of improper connection (change between power and ground), diode is required to protect motor.

Package Dimensions (Unit: mm)

8-SOP-225

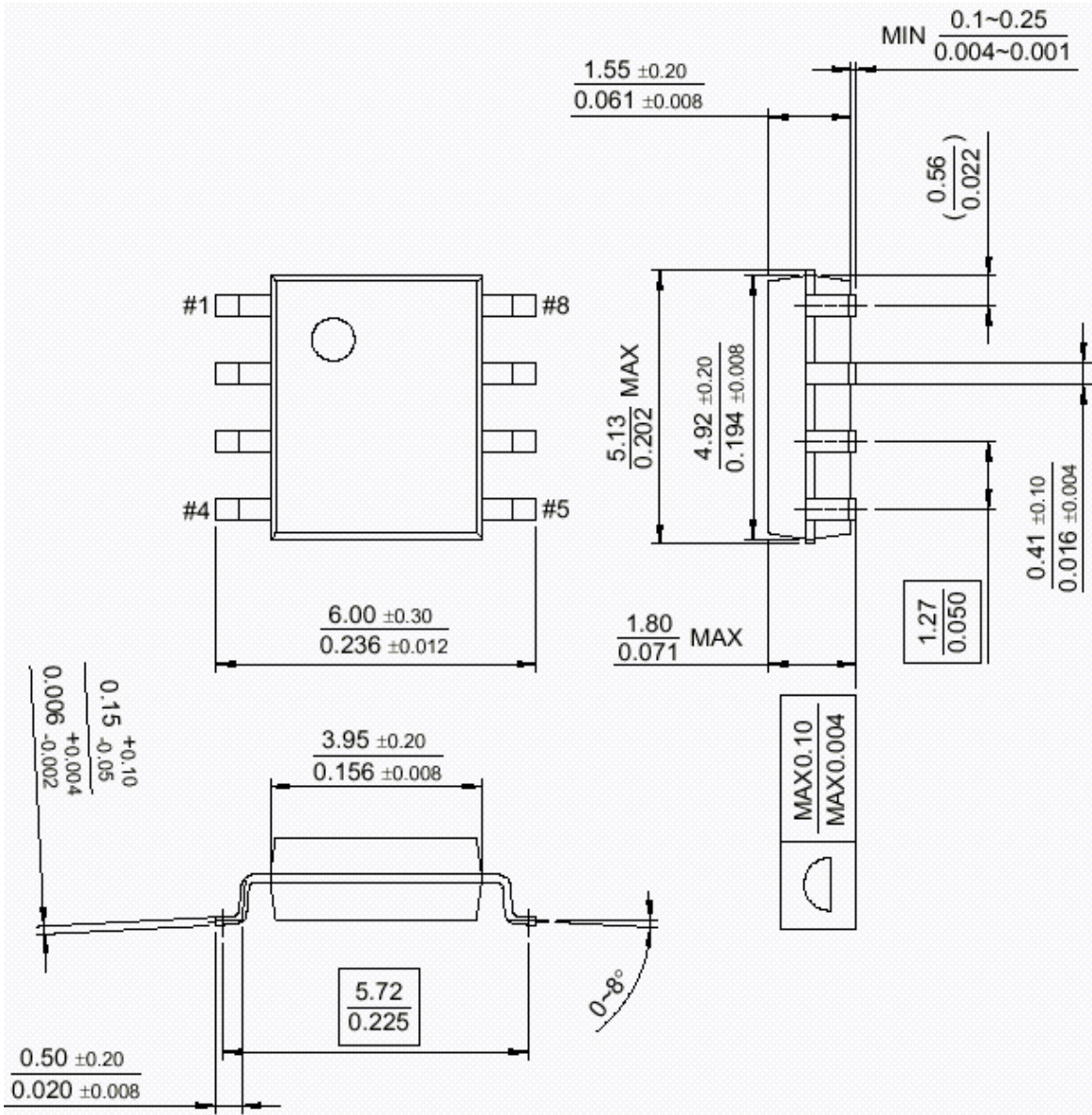

DISCLAIMER

FAIRCHILD SEMICONDUCTOR RESERVES THE RIGHT TO MAKE CHANGES WITHOUT FURTHER NOTICE TO ANY PRODUCTS HEREIN TO IMPROVE RELIABILITY, FUNCTION OR DESIGN. FAIRCHILD DOES NOT ASSUME ANY LIABILITY ARISING OUT OF THE APPLICATION OR USE OF ANY PRODUCT OR CIRCUIT DESCRIBED HEREIN; NEITHER DOES IT CONVEY ANY LICENSE UNDER ITS PATENT RIGHTS, NOR THE RIGHTS OF OTHERS.

LIFE SUPPORT POLICY

FAIRCHILD'S PRODUCTS ARE NOT AUTHORIZED FOR USE AS CRITICAL COMPONENTS IN LIFE SUPPORT DEVICES OR SYSTEMS WITHOUT THE EXPRESS WRITTEN APPROVAL OF THE PRESIDENT OF FAIRCHILD SEMICONDUCTOR CORPORATION. As used herein:

1. Life support devices or systems are devices or systems which, (a) are intended for surgical implant into the body, or (b) support or sustain life, and (c) whose failure to perform when properly used in accordance with instructions for use provided in the labeling, can be reasonably expected to result in a significant injury of the user.
2. A critical component in any component of a life support device or system whose failure to perform can be reasonably expected to cause the failure of the life support device or system, or to affect its safety or effectiveness.