

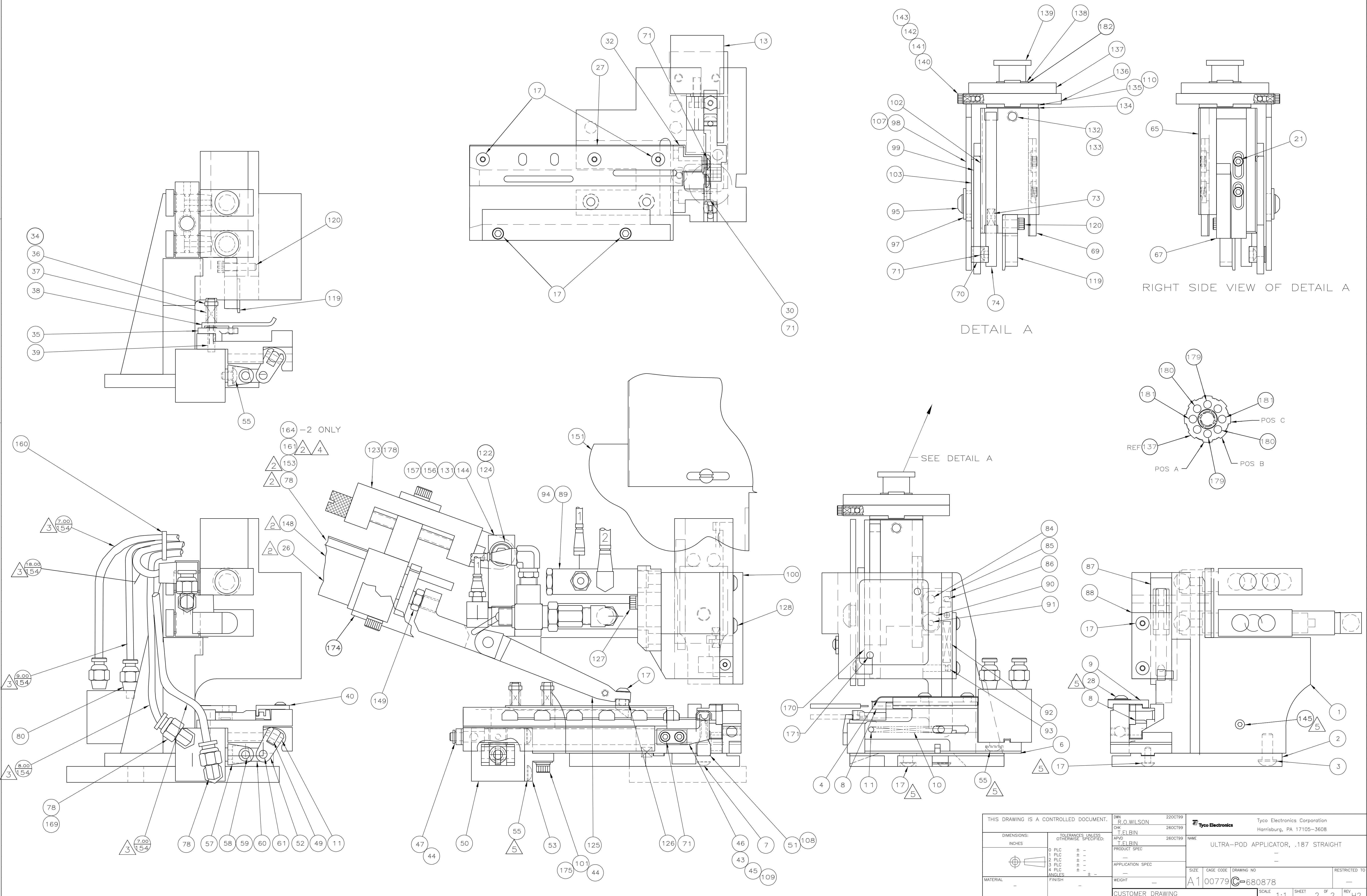

LOC		DIST		REVISIONS				
REV	DATE	DESCRIPTION	DATE	DRN	APVD			
A	66	SEE SHEET 1						



THIS DRAWING IS A CONTROLLED DOCUMENT.		DWN R. O. WILSON	220CT99	Tyco Electronics Corporation Harrisburg, PA 17105-3608	
DIMENSIONS: INCHES		TOLERANCES UNLESS OTHERWISE SPECIFIED:		NAME ULTRA-POD APPLICATOR, .187 STRAIGHT	
0 PLC ± .005		1 PLC ± .002		PRODUCT SPEC	
1 PLC ± .002		2 PLC ± .002		APPLICATION SPEC	
2 PLC ± .002		3 PLC ± .002		SIZE A1	
3 PLC ± .002		4 PLC ± .002		CAGE CODE 00779	
ANGLES ± .005		FINISH		DRAWING NO 680878	
MATERIAL		WEIGHT		RESTRICTED TO	
				CUSTOMER DRAWING	
		SCALE 1:1		SHEET 2 OF 2	
				REV H2	