

300W CONVECTION COOLED

AC-DC POWER SUPPLIES

The extremely high power density AQM300 series of medical external power supplies is fully approved to international medical safety standards. It has been designed with very high efficiency and low standby power, enabling it to meet the latest environmental legislation. The use of technology allows the volume to be typically half that of a traditional design.

The unit has a fully sealed enclosure complying with IP22 and a smooth surface finish making it easier to keep clean in a clinical setting.

Class I and Class II versions ensure versatility for both hospital and non hospital applications.



Features

- Medical safety approvals
- Home healthcare approval
- Energy efficiency level VI
- 4th edition medical EMC
- IP22 environmental rating
- Class I and Class II versions
- <0.5W standby power
- 0°C to 60°C operation
- Low earth leakage current
- 3 year warranty

Applications



Dimensions

7.2" x 3.35" x 1.38" (183 x 85 x 35mm)

Models & Ratings

Model number ⁽¹⁾	Output Voltage	Output Current	Total Regulation	Efficiency ⁽²⁾
AQM300PS12	12.0V	24.0A	5%	90.3%
AQM300PS15	15.0V	20.0A		91.5%
AQM300PS19	19.0V	15.79A		93.4%
AQM300PS24	24.0V	12.5A		92.8%
AQM300PS48	48.0V	6.25A		93.8%

Notes:

1. For class II versions, add suffix 'C2' to the end of the part number e.g. AQM300PS24C2.
2. Measured at full load and 230VAC.

Input

Characteristic	Minimum	Typical	Maximum	Units	Notes & Conditions
Input Voltage	85		264	VAC	Derate linearly from 100% load at 90VAC to 85% load at 85VAC
Input Frequency	47		63	Hz	
Power Factor		>0.9			EN61000-3-2 class A
Input Current		3.5/1.5		A	115/230VAC
Inrush Current			150	A	230VAC cold start, 25°C
Earth Leakage Current		200	500	μA	264VAC, 60Hz, class I versions only
No load Input Power			0.4	W	
Input Protection	T5A/250V Internal fuse fitted in line and neutral				
LED Indicator	Green LED indicates AC present				

Output

Characteristic	Minimum	Typical	Maximum	Units	Notes & Conditions
Output Voltage	12		48	VDC	See Models and Ratings table
Initial Set Accuracy			±2	%	50% load
Minimum Load	No minimum load required				
Start Up Delay		1	1.5	s	
Start Up Rise Time		30	35	ms	115VAC
Hold Up Time	10			ms	Full load and 115/230VAC
Line Regulation			±0.5	%	90-264 VAC
Total Regulation	See Model and Ratings table, includes initial set accuracy, line and load regulation				
Transient Response			4	%	Recovery within 1% in less than 500μs for a 50-75% and 75-50% load step
Ripple and Noise			1.0	% pk-pk	20MHz bandwidth and 10μF electrolytic capacitor in parallel with 0.1μF ceramic capacitor
Overshoot		5	10	%	At turn on/turn off
Overload Protection		150	180	%	
Overvoltage Protection	110		180	%	Recycle mains to reset
Short Circuit Protection	Trip and restart (hiccup), auto resetting				
Temperature Coefficient		0.2		%/°C	
Standby Leakage Current		85	100	μA	264VAC, 60Hz

Environmental

Characteristic	Minimum	Typical	Maximum	Units	Notes & Conditions
Operating Temperature	0		+60	°C	Derate linearly from 100% load at 40°C to 50% load at 60°C, safety approved to 40°C
Cooling	Natural convection				
Operating Humidity			95	%RH	Non-condensing
Storage Temperature			80	°C	
Operating Altitude			3000	m	
Shock	IEC68-2-27, 30 g, 11 ms half sine, 3 times in each of 6 axes				
Vibration	IEC68-2-6, 10-500 Hz, 2 g 10 mins/sweep, 60 mins for each of 3 axes				

Derating Curve

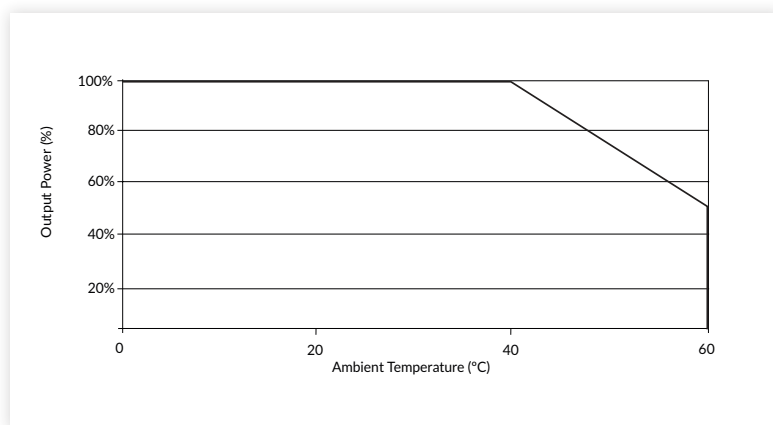

General

Characteristic	Minimum	Typical	Maximum	Units	Notes & Conditions
Efficiency	91	93		%	See Models and Ratings table
Isolation: Input to Output			4000	VAC	2 x MOPP
Input to Ground			1800	VAC	1 x MOPP (Class I versions only)
Output to Ground			500	VAC	Class I versions only
Switching Frequency	65			kHz	PFC
	100		300		Main converter
Power Density		9		W/in ³	
Mean Time Between Failure		>300		khrs	TELCORDIA SR-322 @ 25°C
Weight		2.31 (1050)		lb(g)	

EMC: Emissions

Phenomenon	Standard	Test Level	Notes & Conditions
Conducted	EN55011	Level B	
Radiated			
Harmonic Currents	EN61000-3-2	Class A	
Voltage Flicker	EN61000-3-3		

EMC: Immunity

Phenomenon	Standard	Test Level	Criteria	Notes & Conditions
ESD Immunity	EN61000-4-2	4	A	±8kV contact / ±15kV air discharge
Radiated Immunity	EN61000-4-3	10V/m	A	
EFT/Burst	EN61000-4-4	2	A	
Surge	EN61000-4-5	Installation class 3	A	
Conducted	EN61000-4-6	6V	A	
Magnetic Field	EN61000-4-8	4	A	
Dips and Interruptions	EN60601-1-2	Dip: 30% 25 AC cycles	A/B	115VAC and above/100VAC
		Int: 100% 0.5 AC cycles	A	
		Int: 100% 1.0 AC cycles	B	
		Int: 100% 250 AC cycles	B	

Safety Approvals

Safety Agency	Standard	Notes & Conditions
UL	ANSI/AAMI ES 60601-1	
CSA	CSA C22.2 No. 60601-1	
TUV	EN60601-1 / EN60601-1-11	60601-1-11 is only for Class II versions
CB	IEC60601-1 / IEC60601-1-11	
CE	Meets all applicable directives	
UKCA	Meets all applicable legislation	

Mechanical Details

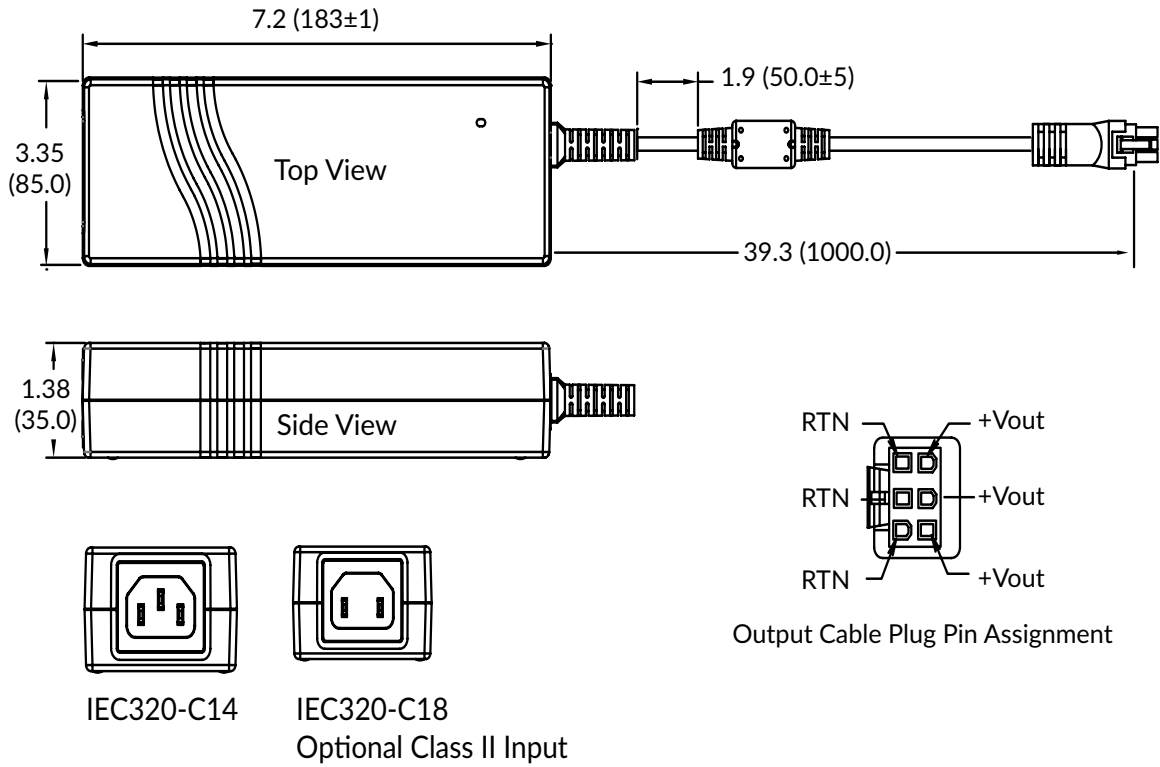

Notes:

1. All dimensions shown in inches (mm). Tolerance is 0.02 (0.5) maximum, except output cable length.
2. Weight: 2.31lbs (1050g) approx.
3. Output connector: 6 pin Molex Mini-Fit series with 39-01-2060 housing and 39-00-0077 terminals. Mates with Molex series 5566 headers or equivalent.