

THIS DRAWING IS UNPUBLISHED. RELEASED FOR PUBLICATION
 © COPYRIGHT - By - ALL RIGHTS RESERVED.

LOC		DIST		REVISIONS			
P	LTR	DESCRIPTION	DATE	DWN	APVD		
	B	RELEASED PER ECO 14-019221	12-22-14	CT	DW		

COMPONENT	MATERIAL	FINISH
HOUSING CAP	BRASS PER ASTM-B-16 HALF HARD	NICKEL PLATE PER AMS-QQ-N-290
DIELECTRIC	TFE FLUOROCARBON PER ASTM-D-1457	N/A
CENTER CONTACT	BERYLLIUM COPPER PER ASTM B 196, ALLOY C17300, CONDITION H	GOLD PLATE PER ASTM-B-488

- 1. THIS AREA TINNED USING LEAD FREE SOLDER ALLOY I.A.W. J-STD-001.
- 2. CAPTURED CENTER CONTACT

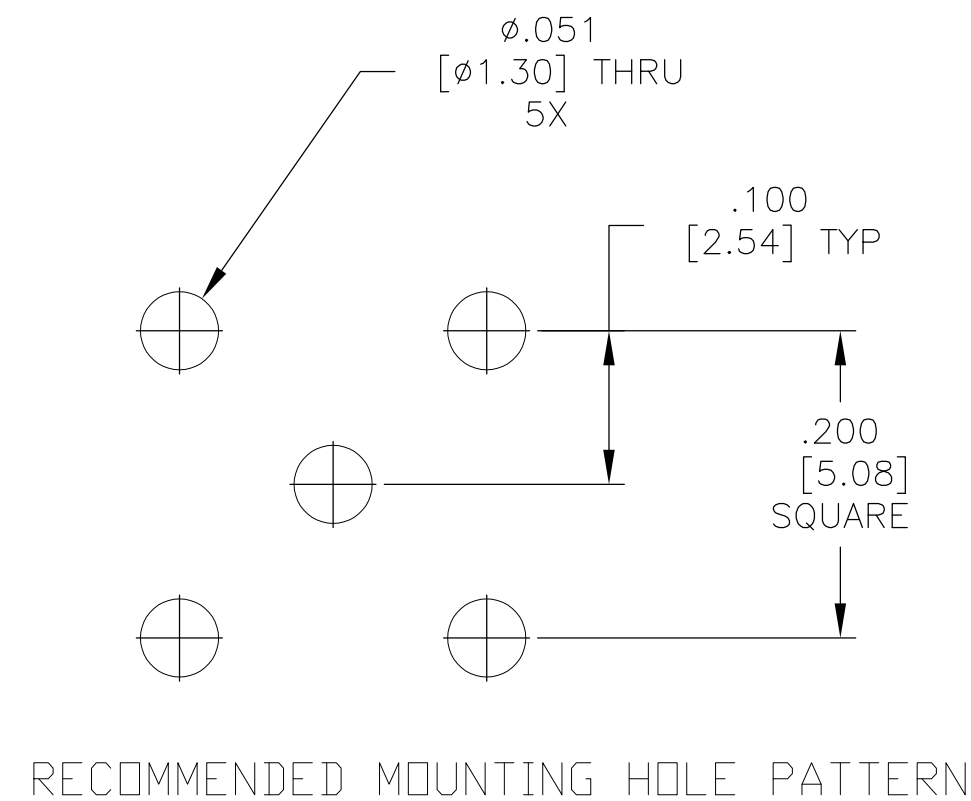
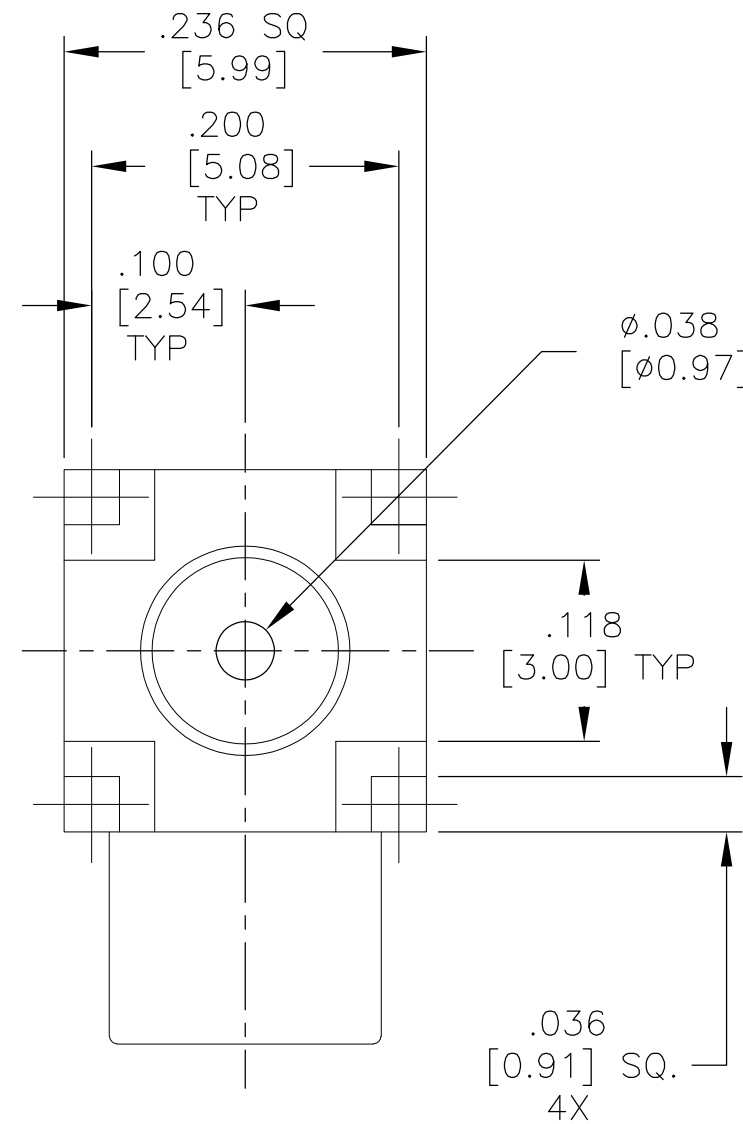
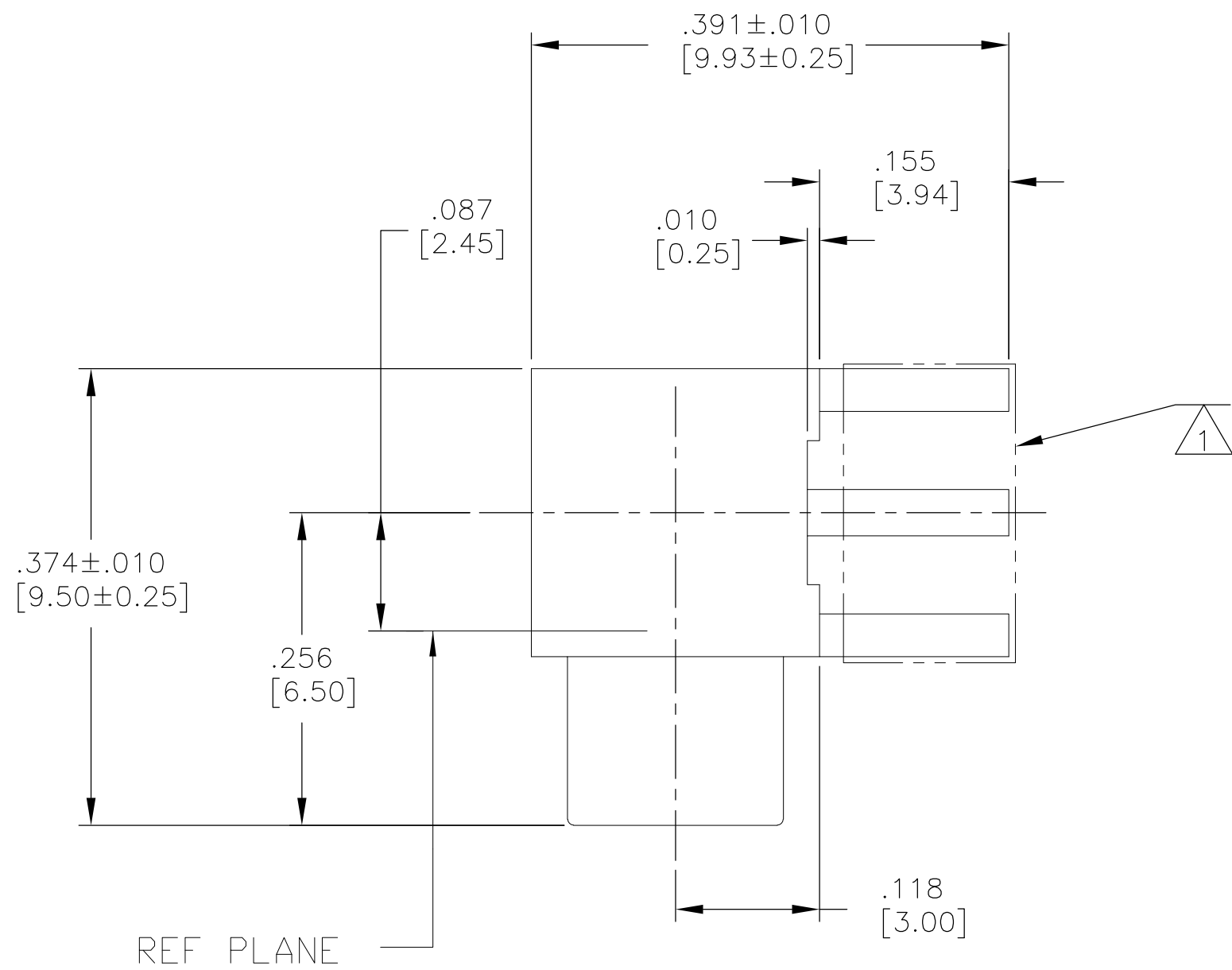

ELECTRICAL	MECHANICAL	ENVIRONMENTAL
Nominal Impedance (Ohms) 50	Force to Engage: (Lbs) 3.4 MAX	Temperature Rating -65° to +165°C
Frequency Range (GHz) DC to 6.0	& Disengage: (Lbs) 1.77 MIN - 4.5 MAX	Vibration MIL-STD-202, Method 204, Condition B
Volt Rating (VRMS MAX) @ Sea Level 335	Center Contact Captivation Axial (Lbs) 4.5 @ 1 minute with .006" Displacement	Thermal Shock MIL-STD-202, Method 107, Condition b
VSWR 1.2:1 MAX		Moisture Resistance MIL-STD-202, Method 106
Insertion Loss .1dB MAX/1000 MHz		Corrosion - MIL-STD-202, Method 101, Condition B, 48 Hrs
Corona, 70,000 Ft (VRMS MIN) 250		
Dielectric Withstanding Voltage (VRMS MIN) @ Sea Level 1000		
Contact Resistance (Milliohms MAX) Center Contact 5.0 Outer Contact 1.0		
RF High Potential @ Sea Level (VRMS MIN @ 5 MHz) 670		
I.R.(Megohms MIN) 10,000		

2221477-1
PART NUMBER

THIS DRAWING IS A CONTROLLED DOCUMENT.		DWN C.C.THOMAS 12-22-14	TE Connectivity	
DIMENSIONS: INCHES [mm]		CHK D.WILSON 12-22-14		
TOLERANCES UNLESS OTHERWISE SPECIFIED:		APVD D.WILSON 12-22-14	NAME MCX JACK PCB RIGHT ANGLE	
0 PLC ± -	1 PLC ± -	PRODUCT SPEC	SIZE A2	CAGE CODE 00779
2 PLC ± -	3 PLC ± .005 [0.13]	APPLICATION SPEC	DRAWING NO C=2221477	RESTRICTED TO -
4 PLC ± -	ANGLES ± -		SCALE 10:1	SHEET 1 of 1
MATERIAL -	FINISH -	WEIGHT -	CUSTOMER DRAWING	REV B