

Delta Electronics, Inc.
 252, SHANGYING ROAD, GUISHAN INDUSTRIAL ZONE,
 TAOYUAN CITY 33341, TAIWAN

TEL : 886-(0)3-3591968
 FAX : 886-(0)3-3591991

Specification For Approval

Customer : _____

Description : DC FAN

Customer P/N : _____

rev. : _____

Delta model no. : THC1748MGCGP

Delta Safety Model No.: THC1748MG

Sample revision. : 01

Issue no.: _____

Sample issue date : DEC.21 2017

Quantity : PCS

1. SCOPE:

THIS SPECIFICATION DEFINES THE ELECTRICAL AND MECHANICAL CHARACTERISTICS OF THE DC BRUSHLESS AXIAL FLOW FAN.

THE FAN MOTOR IS WITH SINGLE PHASE AND EIGHT POLES.

2. CHARACTERS:

ITEM	DESCRIPTION
RATED VOLTAGE	48V
OPERATION VOLTAGE	36 - 60.0 VDC
INPUT CURRENT(AVG.) (AT FREE AIR)	0.60 (MAX. 0.90) A SAFETY CURRENT ON LABEL : 0.90A
INPUT POWER(AVG.) (AT FREE AIR)	28.8 (MAX. 43.2) W
SPEED (AT FREE AIR)	4100 R.P.M. ±10%
MAX. AIR FLOW (AT ZERO STATIC PRESSURE)	8.33 (MIN. 7.50) M ³ /MIN. 294.2 (MIN. 264.8) CFM
MAX. AIR PRESSURE (AT ZERO AIRFLOW)	26.87 (MIN. 21.76) mmH ₂ O 1.06 (MIN.0.86) inchH ₂ O
ACOUSTICAL NOISE (AVG.)	64.5 (MAX. 68.5) dB-A
INSULATION TYPE	UL: CLASS A
INSULATION STRENGTH	10 MEG OHM MIN. AT 500 VDC (BETWEEN PILLOW AND (+) TERMINAL)
DIELECTRIC STRENGTH	5 mA MAX. AT 500 VAC 50/60 Hz ONE MINUTE, (BETWEEN PILLOW AND (+) TERMINAL)

(continued)

PART NO:

DELTA MODEL: THC1748MGCGP

LIFE EXPECTANCE (L10) (AT LABEL VOLTAGE)	70,000 HOURS CONTINUOUS OPERATION AT 40 ° C WITH 15 ~ 65 %RH.
ROTATION	COUNTER CLOCKWISE VIEW FROM NAME PLATE SIDE
AUTO-RESTART	LOCK ROTOR PROTECTED BY ELECTRONIC TIMER WITH AUTOMATIC RESTART FEATURE

NOTES:

1. ALL READINGS ARE MEASURED AFTER STABLY WARMING UP THROUGH 10 MINUTES.
2. STANDARD AIR PROPERTY IS AIR AT (Td) 25°C TEMPERATURE, (RH) 65% RELATIVE HUMIDITY , AND (Pb) 760 mmHg BAROMETRIC PRESSURE.
3. THE VALUES WRITTEN IN PARENS , (), ARE LIMITED SPEC.
4. THE CHARACTERS SHOWED IN PAGE 1 IS THE CONDITION OF BOTH FANS RUN.
5. ACOUSTICAL NOISE MEASURING CONDITION:

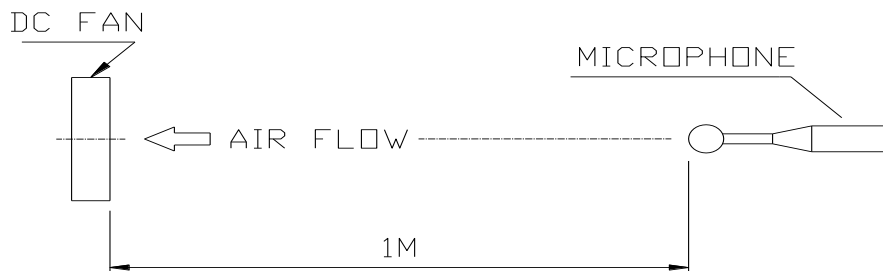

NOISE IS MEASURED AT RATED VOLTAGE IN FREE AIR IN ANECHOIC CHAMBER WITH B & K SOUND LEVEL METER WITH MICROPHONE AT A DISTANCE OF ONE METER FROM THE FAN INTAKE.

PART NO:

DELTA MODEL: THC1748MGCGP

3. MECHANICAL:

- 3-1. DIMENSIONS----- SEE DIMENSIONS DRAWING
- 3-2. FRAME----- PA66-GF30%-Fr UL: 94V-0
- 3-3. IMPELLER----- PA66-GF30%-Fr UL: 94V-0
- 3-4. BEARING SYSTEM----- TWO BALL BEARINGS
- 3-5. WEIGHT----- 607 GRAMS(REF.)

4. ENVIRONMENTAL:

- 4-1. OPERATING TEMPERATURE----- -10 TO +70 DEGREE C
- 4-2. STORAGE TEMPERATURE----- -40 TO +75 DEGREE C
- 4-3. OPERATING HUMIDITY----- 5 TO 90 % RH
- 4-4. STORAGE HUMIDITY----- 5 TO 95 % RH

5. PROTECTION:

- 5-1. LOCKED ROTOR PROTECTION
IMPEDANCE OF MOTOR WINDING PROTECTS MOTOR FROM FIRE IN
96 HOURS OF LOCKED ROTOR CONDITION AT THE RATED VOLTAGE.
- 5-2. POLARITY PROTECTION
BE CAPABLE OF WITHSTANDING IF REVERSE CONNECTION FOR
POSITIVE AND NEGATIVE LEADS.
- 5-3. INGRESS PROTECTION
THE FAN MEET GR-487 SALT FOG TEST AND A MOTOR ENCLOSURE
RATE IP-68.

6. RE OZONE DEPLETING SUBSTANCES:

- 6-1. NO CONTAINING PBBs, PBBOs, CFCs, PBBEs, PBDPEs AND HCFCs.

7. PRODUCTION LOCATION

- 7-1. PRODUCTS WILL BE PRODUCED IN CHINA OR THAILAND.

PART NO:

DELTA MODEL: THC1748MGCGP

8. P & Q CURVE:

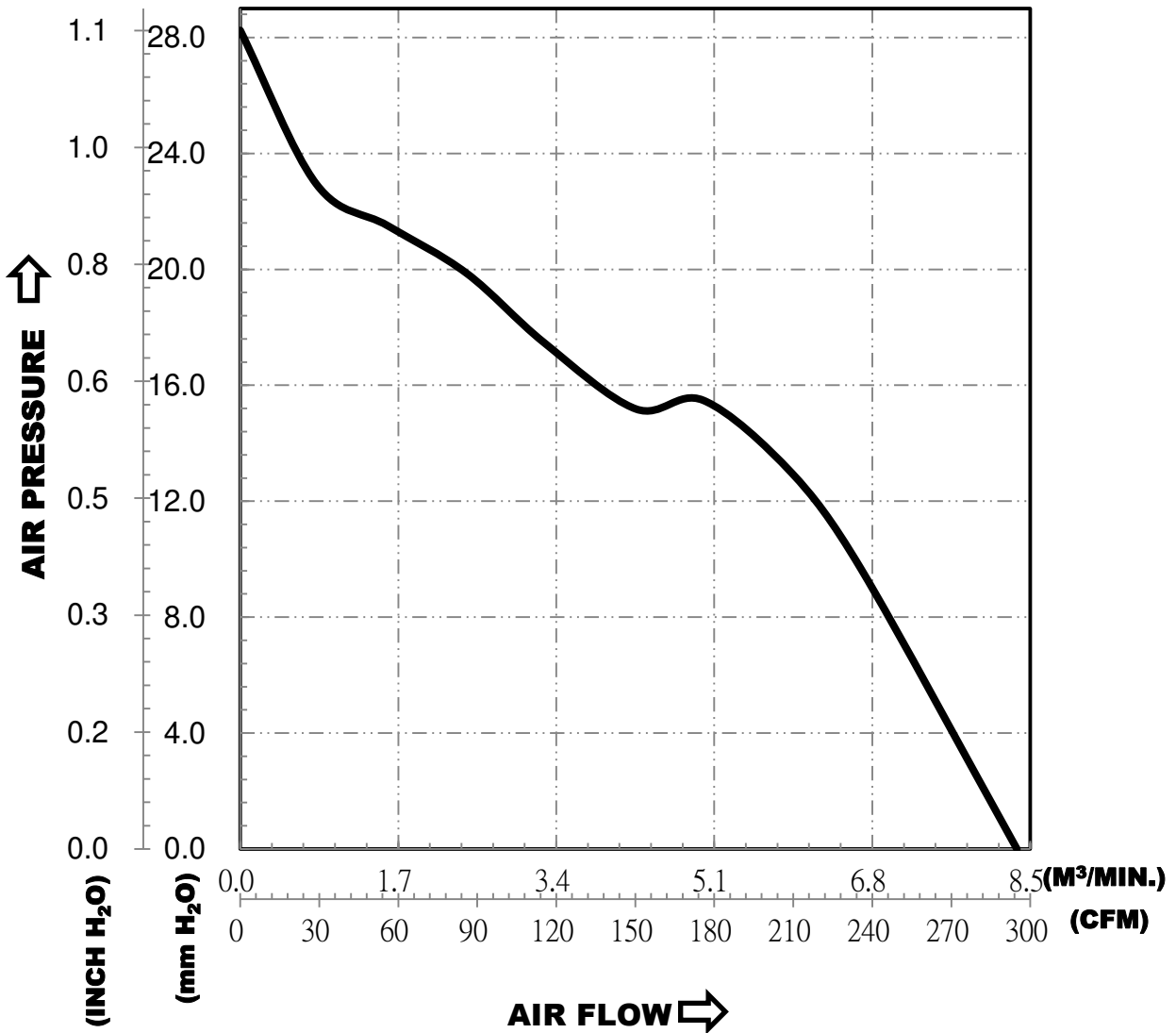

*TEST CONDITION: INPUT VOLTAGE-----OPERATION VOLTAGE
TEMPERATURE-----ROOM TEMPERATURE
HUMIDITY-----65%RH

PART NO:

DELTA MODEL: THC1748MGCGP

9. DIMENSION DRAWING:

LABEL:

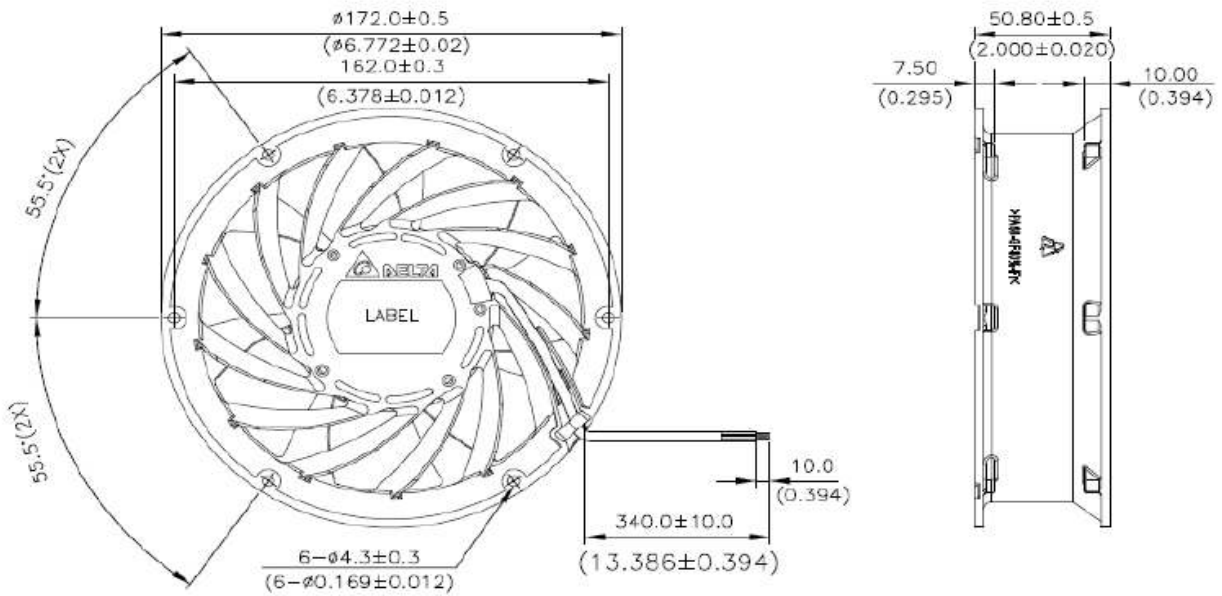
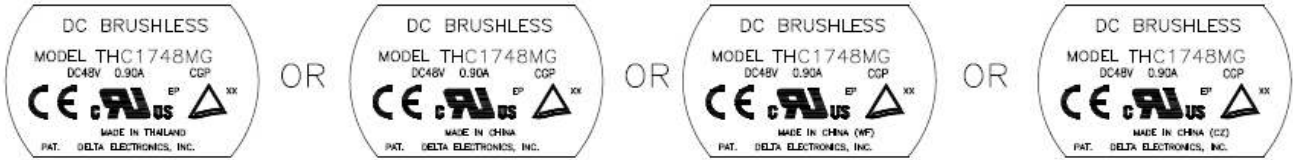

UNIT: mm(INCH)

NOTES:

1. LEAD WIRE: PVC WIRE UL2464 AWG#24
PIN 1: RED WIRE----(+)
PIN 2: YELLOW WIRE----(PWM)
PIN 3: BLUE WIRE----(F00)
PIN 4: BLACK WIRE----(-)
2. THIS PRODUCT IS ROHS COMPLIANT.

PART NO:

DELTA MODEL: THC1748MGCGP

10. FREQUENCY GENERATOR (FG) SIGNAL:

1. OUTPUT CIRCUIT - OPEN COLLECTOR MODE:

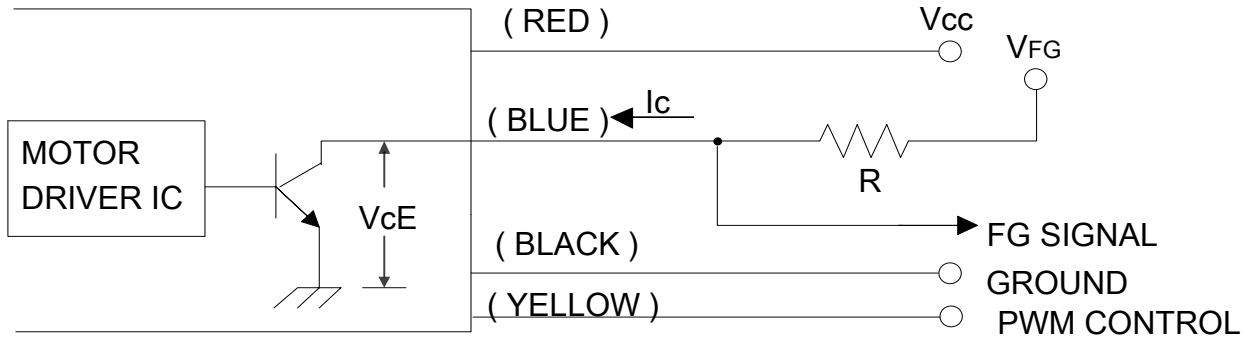

CAUTION:

THE LEAD WIRE OF FG SIGNAL CAN NOT TOUCH THE LEAD WIRE OF POSITIVE OR NEGATIVE.

2. SPECIFICATION:

$V_{FG} = 60.0 \text{ V MAX.}$

$I_c = 10 \text{ mA MAX.}$

$V_{CE} = 0.5 \text{ V MAX.}$

$R \geq V_{FG} / I_c$

3. FREQUENCY GENERATOR WAVEFORM:

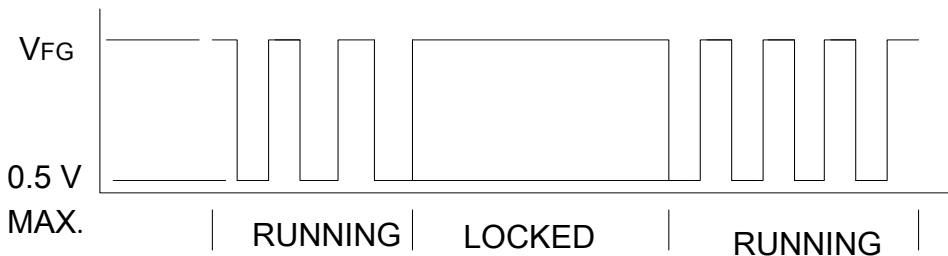

FAN RUNNING FOR 8 POLES

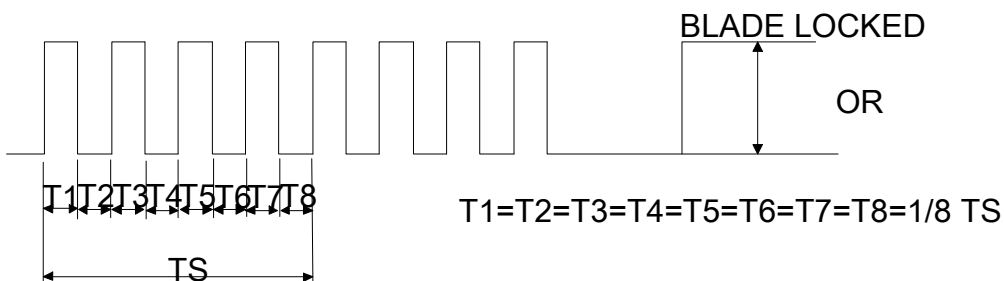

$N = \text{R.P.M}$

$TS = 60/N(\text{SEC})$

*VOLTAGE LEVEL AFTER BLADE LOCKED

*8 POLES

PART NO:

DELTA MODEL: THC1748MGCGP

11. PWM CONTROL SIGNAL:

SIGNAL VOLTAGE RANGE: -0.8VDC~20VDC

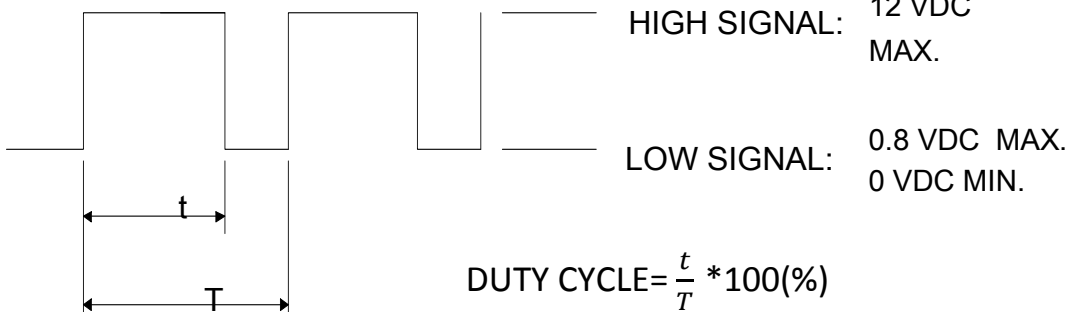

- *THE FREQUENCY FOR CONTROL SIGNAL OF THE FAN SHALL BE ABLE TO ACCEPT A 30KHZ~300KHZ(REF.) WITH DIFFERENT SPEED PERFORMANCE.
- *THE PREFERRED OPERATING POINT FOR THE FAN IS 1 KHZ.
- *AT 100% DUTY CYCLE & 48VDC,THE ROTOR WILL SPIN AT MAXIMUM SPEED.
- *AT 0% DUTY CYCLE & 48VDC, THE ROTOR WILL STOP.
- *WITH CONTROL SIGNAL LEAD DISCONNECTED,THE FAN WILL SPIN AT MAXIMUM SPEED.
- *AT DC48V 1KHZ 20% DUTY CYCLE ,THE FAN WILL BE ABLE TO START FROM A DEAD STOP.

12. SPEED VS PWM CONTROL SIGNAL: (AT 48VDC & PWM F=1KHZ & TEMP=25°C)

(%)	SPEED R.P.M.	CURRENT (A) TYP.
100	4100±10%	0.6
60	3000±10%	0.28
30	2000±10%	0.13
0	0	0.02

13. PWM CONTROL LEAD WIRE INPUT IMPEDANCE:

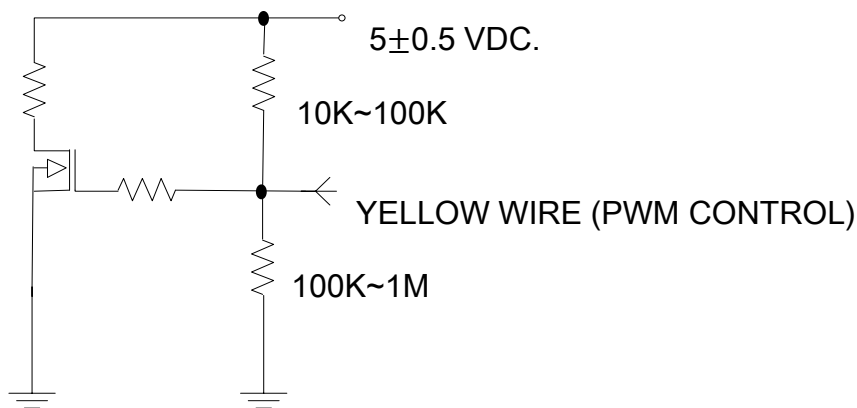

PART NO:

DELTA MODEL: THC1748MGCGP

14. DUTY CYCLE & SPEED CURVE(REF.):

