

| Seating Tool Kit | QSFP Cage Assembly Configuration | Application Specification | Wall Support | Cage Assembly Configuration |
|------------------|----------------------------------|---------------------------|--------------|-----------------------------|
| 2215032-1 | 1 X 6 | 114-13120 | 2215093-6 | 1 X 6 |
| 2215032-2 | 1 X 3 | | 2215093-3 | 1 X 3 |
| 2215032-3 | 1 X 4 | | 2215093-4 | 1 X 4 |
| 2215032-4 | 1 X 6 | | 2215093-6 | 1 X 6 |

Figure 1

1. INTRODUCTION

QSFP cage assembly seating tool kits listed in Figure 1 are used to seat the cage assemblies described in Figure 1 onto a pc board. The cage assembly contains compliant pin contacts to allow solderless pc board installation.

Read these instructions thoroughly before using the seating tool kit.



NOTE

Dimensions on this sheet are in metric units [with U.S. customary units in brackets]. Figures and illustrations are for reference only and are not drawn to scale.

2. DESCRIPTION (Figure 1)

Each seating tool consists of a seating tool and a wall support. The seating tool has cutouts (two located on each side) to accept the protruding part of the standoffs of the cage assembly. The wall support must be installed into the ports of the cage assembly.

The top of the seating tool provides a surface to accept the force applied by the application tool to seat the product onto the pc board. During seating, the back and sides of the seating tool protect the cage assembly from damage. The wall support supports the individual ports of the cage assembly.

3. REQUIREMENTS

3.1. PC Board Support Fixture (Customer Supplied)

A pc board support must be used to provide proper support for the pc board and to protect the pc board and the connector and cage assembly from damage. The support fixture must be designed for specific needs using the following recommendations:

- Should be at least 25.4 mm [1 in.] longer and wider than the pc board
- Should have flat surfaces with holes or a channel large enough and deep enough to receive any protruding components of the product

3.2. Application Tool

Power for seating tools must be provided by an application tool (with a ram) capable of supplying a downward force of 44.5 N [10 lb-force] per contact. For available application tools, call PRODUCT INFORMATION at the number at the bottom of page 1.



CAUTION

Over-driving of the cage assembly will deform parts critical to the quality of the connection. Maximum force occurs prior to the cage assembly bottoming on the pc board.

4. SETUP

When setting up equipment to seat the cage assembly, pay particular attention to the following:

- The seating tool must be matched to the cage assembly



CAUTION

If seating tool / cage assembly are mismatched or improperly aligned, damage could occur to tooling, cage assembly, or both.

- Light pipes **MUST NOT** be assembled onto the cage assembly
- The wall support must be properly installed, and the seating tool, cage assembly, and application tool ram must be properly aligned before cycling the application tool.

1. Set the tool seating height to the dimension shown in Figure 2 (application tool shut height will equal the tool seating height PLUS the combined thicknesses of the pc board and support fixture).

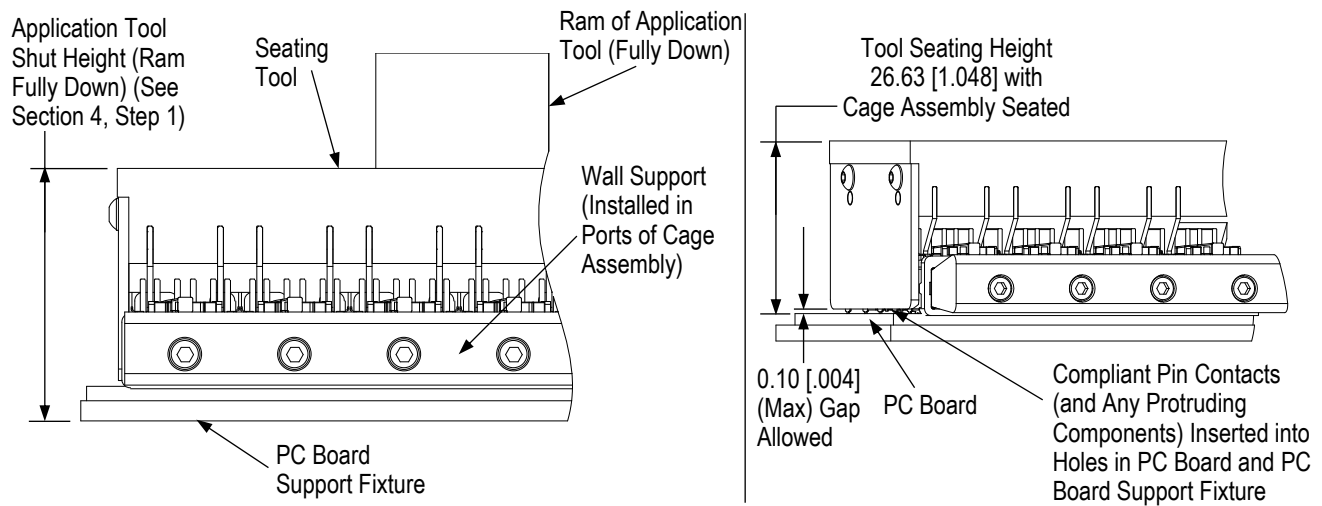

Figure 2

After seating, a gap of no more than 0.10 mm [.004 in.] is allowed between the cage assembly standoffs and the pc board.



NOTE

Use the tool seating height as a reference starting point. This height may need to be adjusted to obtain the amount allowed (maximum of 0.10 mm [.004 in.]) between the standoffs of the cage assembly and the pc board.

2. Slide the wall support into the ports of the cage assembly until the wall support is secure.

5. SEATING (Figure 2)



NOTE

The connector must be mounted on the pc board **BEFORE** seating the cage assembly.

1. Place the pc board on the support fixture.
2. Orient the seating tool over the cage assembly so that the back is aligned with the back of the cage assembly. Then lower the seating tool onto the cage assembly, making sure that the cutouts slide over the protruding components of the cage assembly, until the seating tool bottoms on the top of the cage assembly.
3. Place the cage assembly on the pc board so that the contacts and alignment posts are aligned and started into the matching holes in the pc board.
4. Center the seating tool (with the cage assembly) under the ram of the application tool. Slowly lower the ram until it just meets the seating tool. Verify alignment of pc board support, pc board, cage assembly, and seating tool.



CAUTION

Damage to the pc board, seating tool, or cage assembly may occur if the seating tool is not properly seated on the cage assembly before cycling the application tool.

5. Cycle the application tool to seat the cage assembly on the pc board. Then retract the ram, and carefully remove the seating tool by pulling it straight from the cage assembly.
6. Check the cage assembly for proper seating according to the following:
 - The widest section of each compliant pin is inside its intended pc board hole
 - Each alignment post is in its intended pc board hole
 - If present, the gap between the standoffs and the pc board is no more than 0.10 mm [.004 in.]



NOTE

For detailed application requirements of the cage assembly, refer to the application specification given in Figure 1.

6. MAINTENANCE AND INSPECTION

The seating tool kit is assembled and inspected before shipment. It is recommended that the seating tool kit be inspected immediately upon arrival at your facility to ensure that it has not been damaged during shipment, and that it conforms to the dimensions provided in Figure 3.

6.1. Daily Maintenance

TE recommends that each operator be made aware of, and responsible for, the following steps of daily maintenance:

- Remove dust, moisture, and contaminants with a clean, soft brush or a lint-free cloth. **DO NOT** use objects that could damage the components.
- When the seating tool and wall support are not in use, store them in a clean, dry area.

6.2. Periodic Inspection

Regular inspections should be performed by quality control personnel. A record of scheduled inspections should remain with the seating tool or be supplied to personnel responsible for the seating tool kit. Inspection frequency should be based on amount of use, working conditions, operator training and skill, and established standards.

7. REPLACEMENT AND REPAIR

Customer-replaceable parts are listed in Figure 4. A complete inventory should be stocked and controlled to prevent lost time when replacement of parts is necessary. Parts other than those listed should be replaced by TE Connectivity to ensure quality and reliability. Order replacement parts through your TE Representative, or call 1-800-526-5142, or send a facsimile of your purchase order to 717-986-7605, or write to:

CUSTOMER SERVICE (038-035)
 TYCO ELECTRONICS CORPORATION
 PO BOX 3608
 HARRISBURG PA 17105-3608

8. REVISION SUMMARY

- Updated with most up-to-date enterprise logo and name.
- Added Seating Tool Kit 2215032-4 and updated all wall support part numbers.
- Split Figure 3 into Figure 3 and Figure 4.

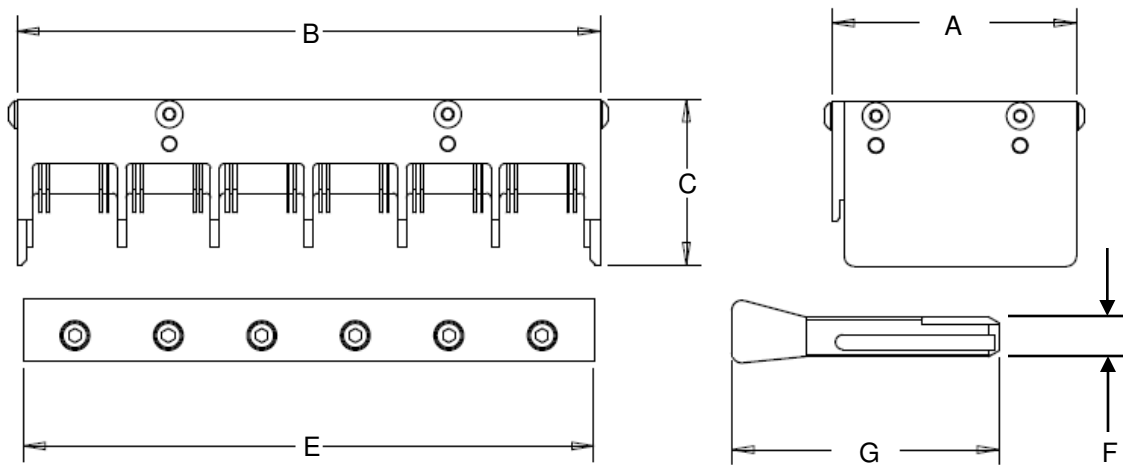

| Seating Tool / Cage Assembly Configuration | Dimension (mm [in.]) | | | | | |
|---|----------------------|--------------|-------------|--------------|------------|-------------|
| | A | B | C | E | F | G |
| 2215032-1 / 1 X 6 | 49.5 [1.95] | 118.6 [4.67] | 33.5 [1.32] | 116.0 [4.57] | 8.15 [.32] | 54.2 [2.13] |
| 2215032-2 / 1 X 3 | 49.5 [1.95] | 61.6 [2.42] | 33.5 [1.32] | 59.0 [2.32] | 8.15 [.32] | 54.2 [2.13] |
| 2215032-3 / 1 X 4 | 49.5 [1.95] | 80.6 [3.17] | 33.5 [1.32] | 78 [3.07] | 8.15 [.32] | 54.2 [2.13] |
| 2215032-4 / 1 X 6 | 49.5 [1.95] | 118.6 [4.67] | 28.5 [1.12] | 116.0 [4.57] | 8.15 [.32] | 54.2 [2.13] |

Figure 3

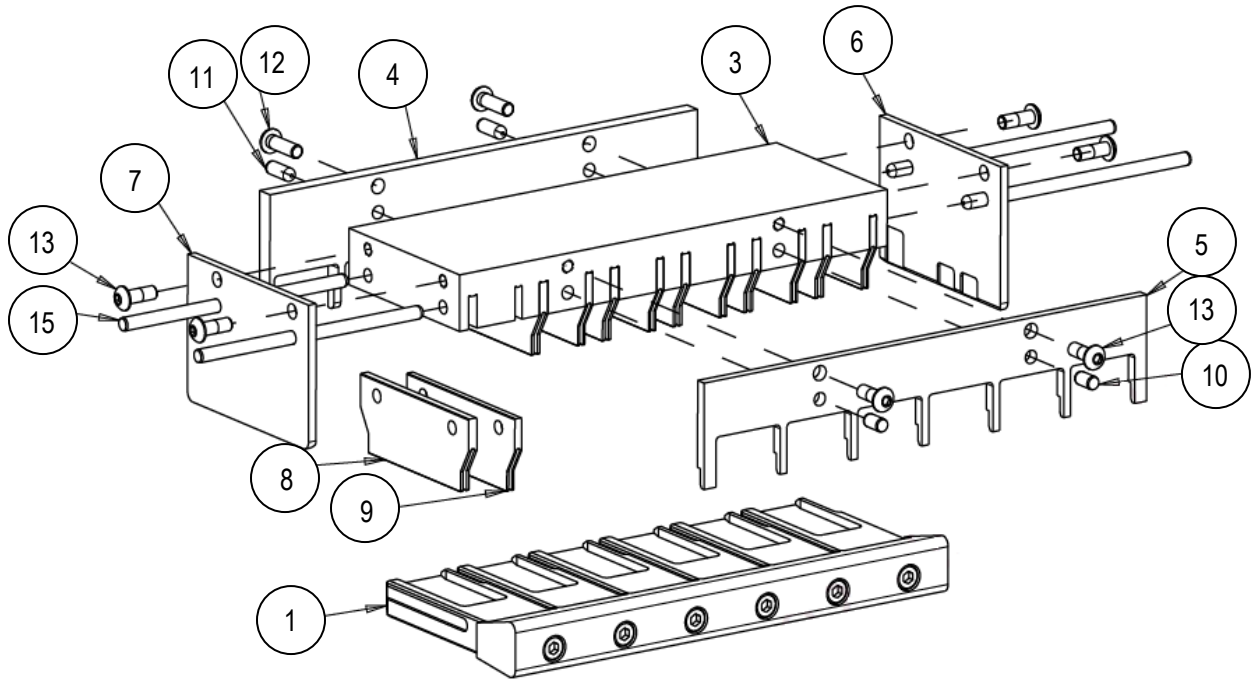

| Replacement Parts | | | Number of Parts per Kit by Kit Number | | | |
|-------------------|---------------------|-------------|---------------------------------------|-----------|-----------|-----------|
| Item | Description | Part Number | Number of Parts per Kit by Kit Number | | | |
| | | | 2215032-1 | 2215032-2 | 2215032-3 | 2215032-4 |
| 1 | Wall Support Assy | 2215093-6 | 1 | | | 1 |
| | | 2215093-3 | | 1 | | |
| | | 2215093-4 | | | 1 | |
| 3 | Center Block | 2215450-1 | 1 | | | |
| | | 2215450-2 | | 1 | | |
| | | 2215450-3 | | | 1 | |
| | | 2215450-4 | | | | 1 |
| 4 | Rear Plate | 2215451-1 | 1 | 1 | | |
| | | 2215451-2 | | | | |
| | | 2215451-3 | | | 1 | |
| | | 2215451-4 | | | | 1 |
| 5 | Front Plate | 2215871-1 | 1 | | | |
| | | 2215871-2 | | 1 | | |
| | | 2215871-3 | | | 1 | |
| | | 2215871-4 | | | | 1 |
| 6 | Right Side Plate | 2215453-1 | 1 | 1 | 1 | |
| | | 2215453-2 | | | | 1 |
| 7 | Left Side Plate | 2215452-1 | 1 | 1 | 1 | |
| | | 2215452-3 | | | | 1 |
| 8 | Insert Plate | 2215449-1 | 6 | 3 | 4 | |
| 9 | Insert Plate | 2215449-2 | 6 | 3 | 4 | |
| 10 | Dowel Pin | 2-992946-8 | 2 | 2 | 2 | 2 |
| 11 | Dowel Pin | 1-992946-4 | 2 | 2 | 2 | 2 |
| 12 | Screw, Btn Head Cap | 18024-3 | 2 | 2 | 2 | 2 |
| 13 | Screw, Btn Head Cap | 18024-2 | 6 | 6 | 6 | 6 |
| 15 | Dowel Pin | 2-992946-7 | 4 | | | |
| | | 7-992946-5 | | 4 | | |
| | | 7-992946-8 | | | 4 | |

Figure 4