

3.0 x 3.0 x 3.3 (mm) Bluetooth Chip PCB Substrate Antenna (EVB+CW337)

Engineering Specification

1. Product Number

H 2 B 1 C B 1 A 1 B 0 1 0 0

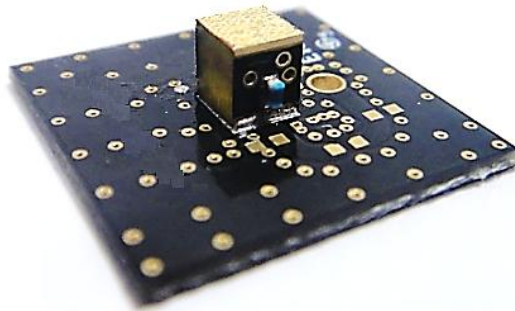

2. Features

- *No ground clearance requirement.
- *Vertical polarization.
- *Stable and reliable in performance.
- *RoHS 2.0 compliance
- *SMT processes compatible

3. Applications

- *Wireless earbud
- *Wearable device
- *ISM 2.4 GHz
- *ZigBee/BLE

4. Description

Unictron's CW337 pillar antenna is specifically designed for ISM 2.4GHz, ZigBee, BLE, IoT, wearable, etc. applications where there is no space for usual/typical antenna ground clearance. Fabricated with proprietary design and processes, CW337 shows excellent performance and is fully compatible with SMT processes which can decrease the assembly cost and improve device's quality and consistency.



詠業科技股份有限公司
Unictron Technologies Corporation
Website:www.unictron.com

THIS DRAWINGS AND SPECIFICATIONS ARE THE PROPERTY OF UNICTRON TECHNOLOGIES CORPORATION AND SHALL NOT BE REPRODUCED OR USED AS THE BASIS FOR THE MANUFACTURE OR SALE OF APPARATUS OR DEVICES WITHOUT PERMISSION

Prepared by : Wen Designed by : Peter Checked by : Mike Approved by : Herbert

TITLE : 3.0 x 3.0 x 3.3 (mm) Bluetooth Chip PCB Substrate Antenna (EVB+CW337) Engineering Specification	DOCUMENT NO.	H2B1CB1A1B0100	REV.
			A

5. Layout Guide & Electrical Specifications

5-1. Layout Guide (Unit : mm)

Solder Land Pattern:

The solder land pattern (gold marking areas) is shown below, no ground clearance requirement on bottom side. Recommendation on matching circuit will be provided according to customer's installation conditions.

Top Layer View

Inner Layer View

Bottom Layer View

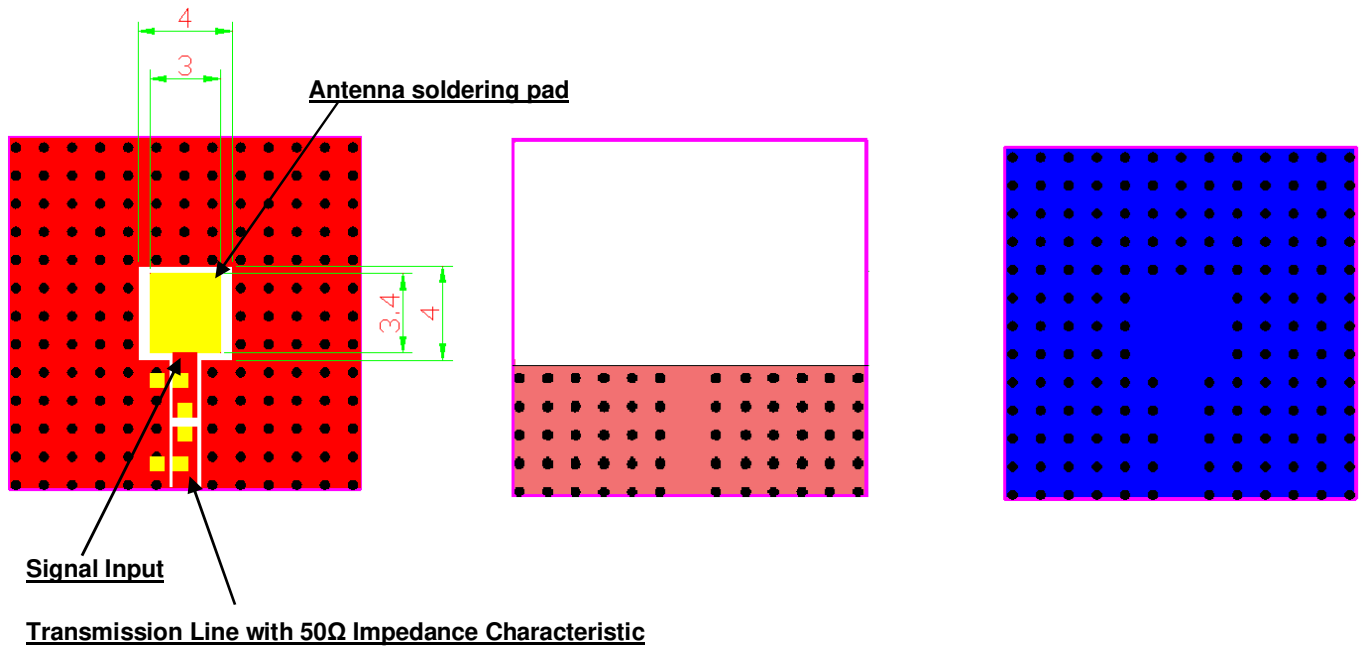

詠業科技股份有限公司
Unictron Technologies Corporation
Website: www.unictron.com

THIS DRAWINGS AND SPECIFICATIONS ARE THE PROPERTY OF UNICTRON TECHNOLOGIES CORPORATION AND SHALL NOT BE REPRODUCED OR USED AS THE BASIS FOR THE MANUFACTURE OR SALE OF APPARATUS OR DEVICES WITHOUT PERMISSION

Prepared by : **Wen**

Designed by : **Peter**

Checked by : **Mike**

Approved by : **Herbert**

**TITLE : 3.0 x 3.0 x 3.3 (mm) Bluetooth Chip PCB Substrate
Antenna (EVB+CW337) Engineering Specification**

**DOCUMENT
NO.**

H2B1CB1A1B0100

**REV.
A**

5-2. Electrical Specifications

5-2-1. Electrical Table

The data was measured with a 15 x 15 mm² EVB which has no ground clearance on opposite side. The material of substrate is FR4, thickness is 0.8mm.

Characteristics		Specifications	Unit
Outline Dimensions		3.0 x 3.0 x 3.3	mm
Ground Plane Dimensions		15 x 15	mm
Working Frequency		2400~ 2500	MHz
VSWR (@ center frequency)*		2 Max.	
Characteristic Impedance		50	Ω
Polarization		Vertical Polarization	
Peak Gain	(@2442 MHz)	-0.4(typical)**	dBi
Efficiency		25.6(typical)**	%

*Center frequency means the frequency with the lowest value in return loss of the chip antenna on the evaluation board.

**A Typical value is for reference only, not guaranteed.

5-2-2. Frequency vs. V.S.W.R. and Total Radiation Gain

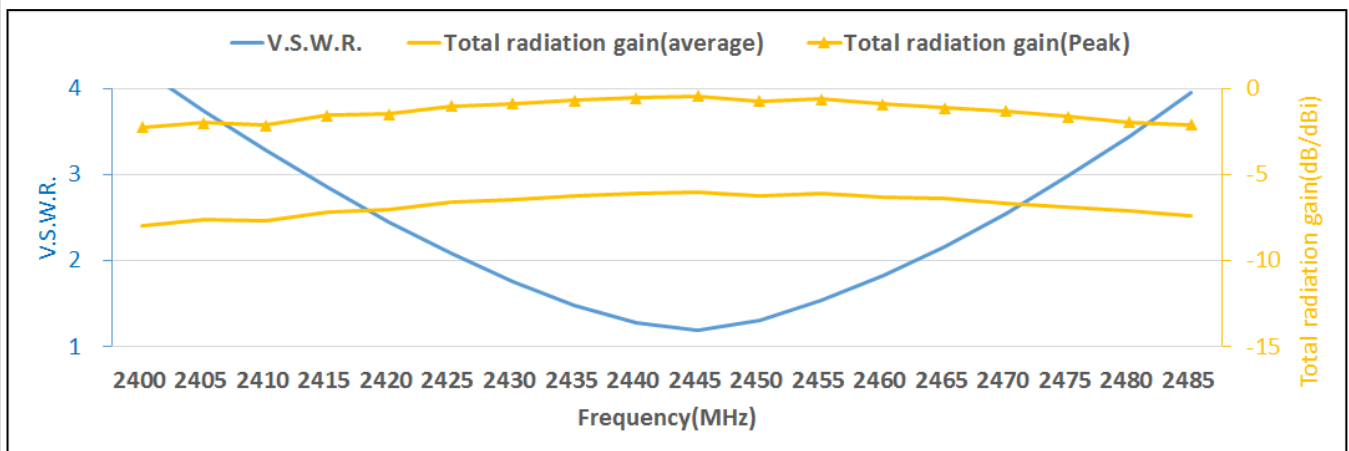

詠業科技股份有限公司
Unictron Technologies Corporation
Website: www.unictron.com

THIS DRAWINGS AND SPECIFICATIONS ARE THE PROPERTY OF UNICTRON TECHNOLOGIES CORPORATION AND SHALL NOT BE REPRODUCED OR USED AS THE BASIS FOR THE MANUFACTURE OR SALE OF APPARATUS OR DEVICES WITHOUT PERMISSION

Prepared by : Wen

Designed by : Peter

Checked by : Mike

Approved by : Herbert

TITLE : 3.0 x 3.0 x 3.3 (mm) Bluetooth Chip PCB Substrate
Antenna (EVB+CW337) Engineering Specification

DOCUMENT
NO.

H2B1CB1A1B0100

REV.
A

6-3. Evaluation Board with Antenna

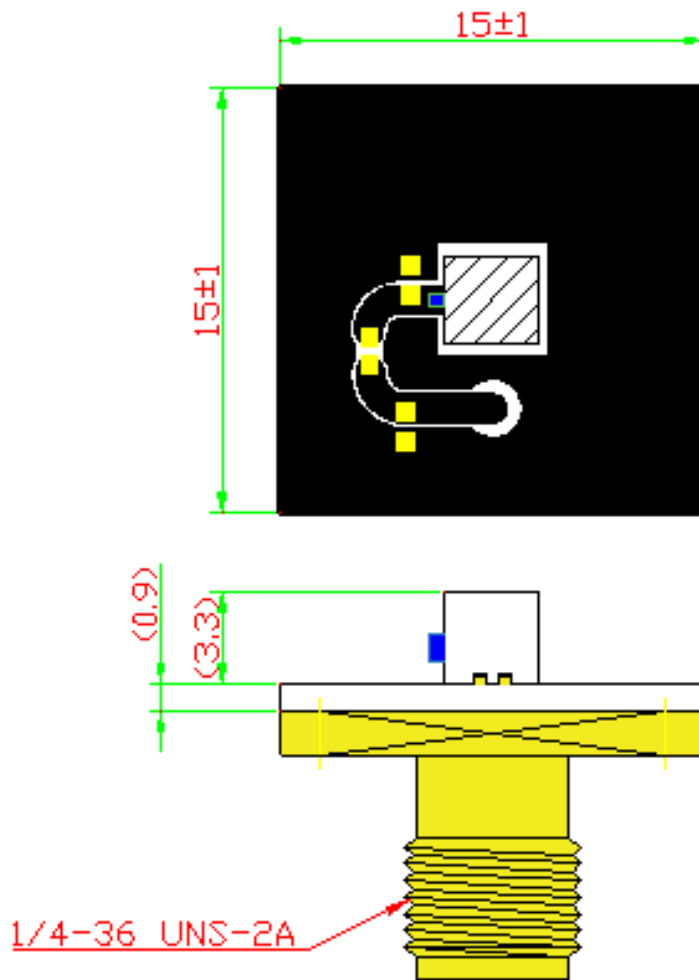

Unit: mm



詠業科技股份有限公司
Unictron Technologies Corporation
Website: www.unictron.com

THIS DRAWINGS AND SPECIFICATIONS ARE THE PROPERTY OF UNICTRON TECHNOLOGIES CORPORATION AND SHALL NOT BE REPRODUCED OR USED AS THE BASIS FOR THE MANUFACTURE OR SALE OF APPARATUS OR DEVICES WITHOUT PERMISSION

Prepared by : **Wen**

Designed by : **Peter**

Checked by : **Mike**

Approved by : **Herbert**

**TITLE : 3.0 x 3.0 x 3.3 (mm) Bluetooth Chip PCB Substrate
Antenna (EVB+CW337) Engineering Specification**

**DOCUMENT
NO.**

H2B1CB1A1B0100

**REV.
A**

7. 3D Radiation Gain Pattern (with 15 x 15 mm² Evaluation Board)

3D Radiation Gain Pattern @ 2442 MHz (Unit: dBi)

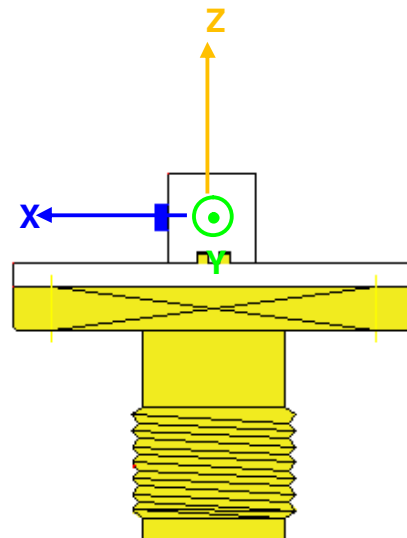
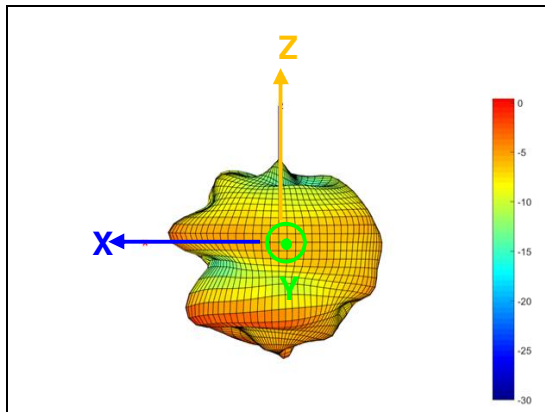
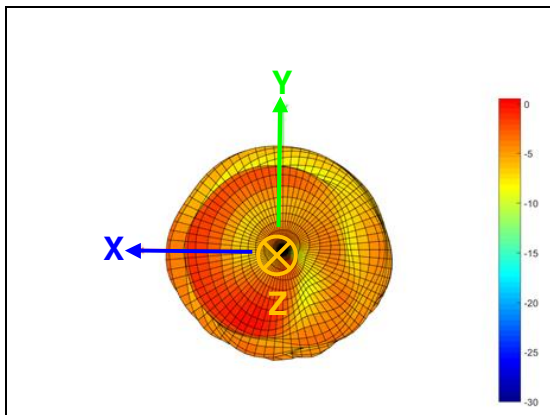
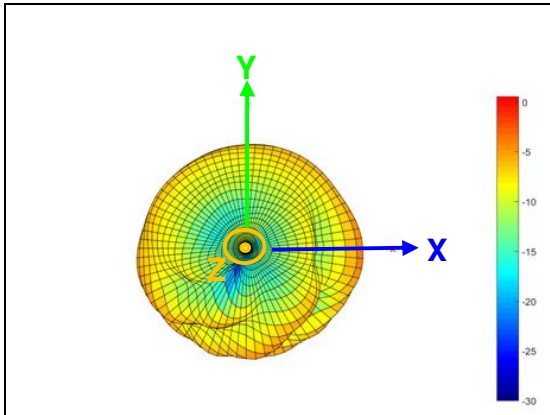

詠業科技股份有限公司
Unicon Technologies Corporation
Website: www.unicon.com

THIS DRAWINGS AND SPECIFICATIONS ARE THE PROPERTY OF UNICON TECHNOLOGIES CORPORATION AND SHALL NOT BE REPRODUCED OR USED AS THE BASIS FOR THE MANUFACTURE OR SALE OF APPARATUS OR DEVICES WITHOUT PERMISSION

Prepared by : Wen

Designed by : Peter

Checked by : Mike

Approved by : Herbert

TITLE : 3.0 x 3.0 x 3.3 (mm) Bluetooth Chip PCB Substrate
Antenna (EVB+CW337) Engineering Specification

DOCUMENT
NO.

H2B1CB1A1B0100

REV.
A

8. Frequency Tuning

8-1. Chip antenna tuning scenario :

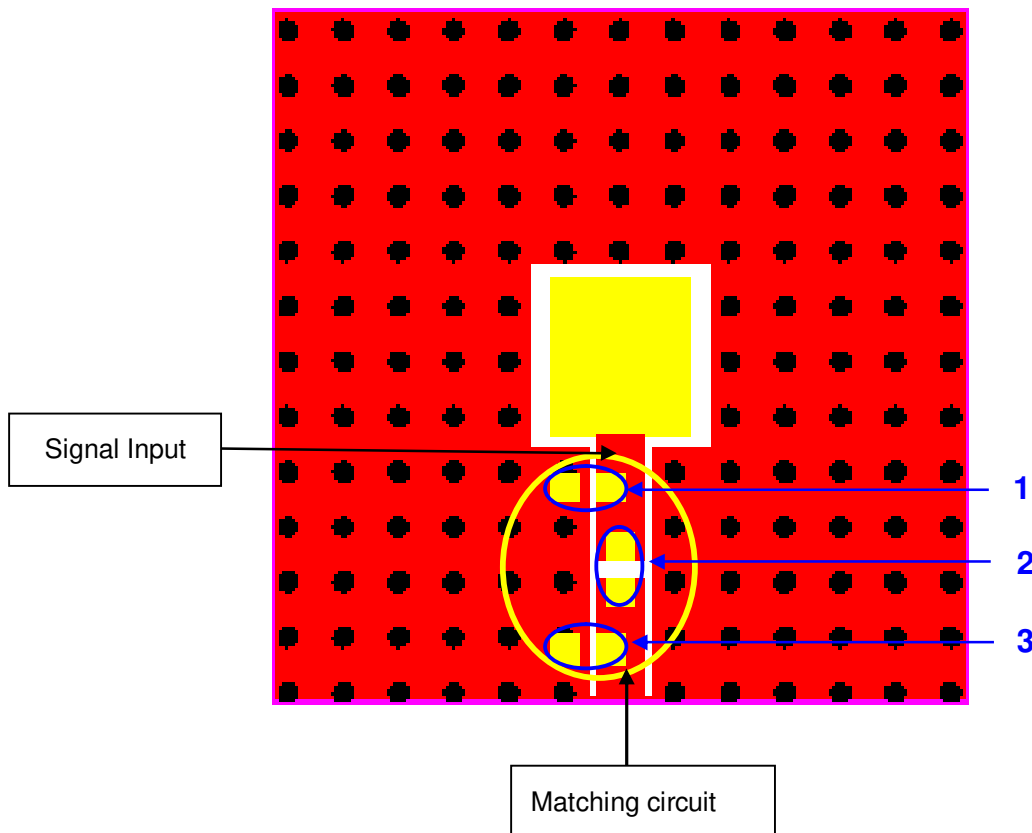

8-2. Matching circuit :

With the following recommended values of matching and tuning components, the center frequencies will be about 2442 MHz at our standard 15 x 15 mm² evaluation board. However, these are typical reference values which may need to be changed when circuit boards or part vendors are different.

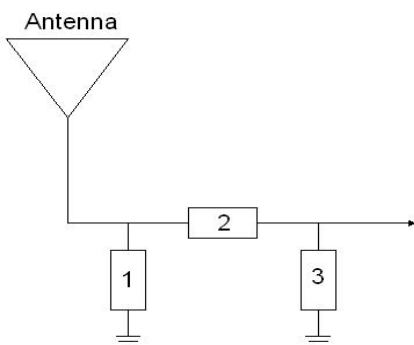

System Matching Circuit Component			
Location	Description	Vendor	Tolerance
1	1.8nH, (0402)	MURATA	±0.1 nH
2	4.7nH, (0402)	MURATA	±0.1 nH
3	NA		

Unictron
Technologies Corp.
2018-09-20
Document
Control Center



詠業科技股份有限公司
Unictron Technologies Corporation
Website:www.unictron.com

THIS DRAWINGS AND SPECIFICATIONS ARE THE PROPERTY OF UNICTRON TECHNOLOGIES CORPORATION AND SHALL NOT BE REPRODUCED OR USED AS THE BASIS FOR THE MANUFACTURE OR SALE OF APPARATUS OR DEVICES WITHOUT PERMISSION

Prepared by : Wen

Designed by : Peter

Checked by : Mike

Approved by : Herbert

TITLE : 3.0 x 3.0 x 3.3 (mm) Bluetooth Chip PCB Substrate
Antenna (EVB+CW337) Engineering Specification

DOCUMENT
NO.

H2B1CB1A1B0100

REV.
A

9. Typical Efficiency Values @ 2442 MHz for Various Placements

The following typical efficiency values represent antenna's performance when antenna was installed at various placements on the evaluation board which has no ground clearance on opposite side.

Placement A

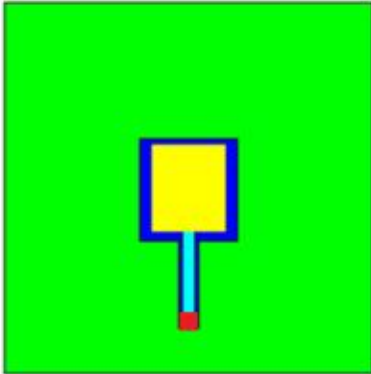

Placement B

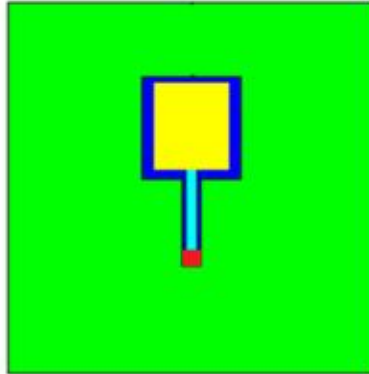

Placement C

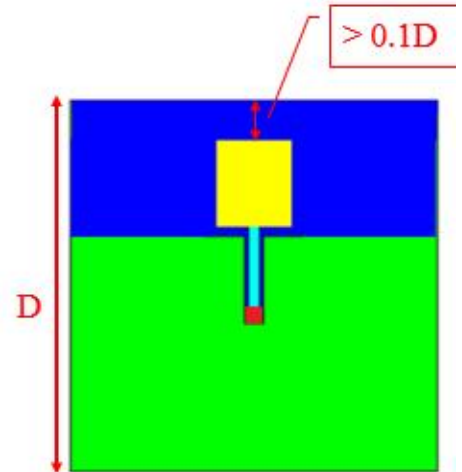

Placement	Efficiency (%)	Recommended scenario of installation
A	25.6*	IoT, ISM, BLE, ZigBee device
B	29.4*	
C	36.2*	Wireless earbud, smart watch

*Measured with a 15x15 mm evaluation board.

For placement A & B, the antenna is polarized in vertical polarization. We encourage you to use antenna for this placement when antenna is installed on a PCB which is not available to have antenna ground clearance, i.e. IoT, ISM, BLE, ZigBee devices, etc. where metal/battery/display covers entire area of opposite side of PCB.

For placement C, we encourage you to use antenna for this placement when antenna is installed in wearable devices, i.e. wireless earbud, smart watch, etc.



詠業科技股份有限公司
Unictron Technologies Corporation
Website: www.unictron.com

THIS DRAWINGS AND SPECIFICATIONS ARE THE PROPERTY OF UNICTRON TECHNOLOGIES CORPORATION AND SHALL NOT BE REPRODUCED OR USED AS THE BASIS FOR THE MANUFACTURE OR SALE OF APPARATUS OR DEVICES WITHOUT PERMISSION

Prepared by : Wen

Designed by : Peter

Checked by : Mike

Approved by : Herbert

TITLE : 3.0 x 3.0 x 3.3 (mm) Bluetooth Chip PCB Substrate
Antenna (EVB+CW337) Engineering Specification

DOCUMENT
NO.

H2B1CB1A1B0100

REV.
A

10. Soldering Conditions

Typical Soldering Profile for Lead-free Process

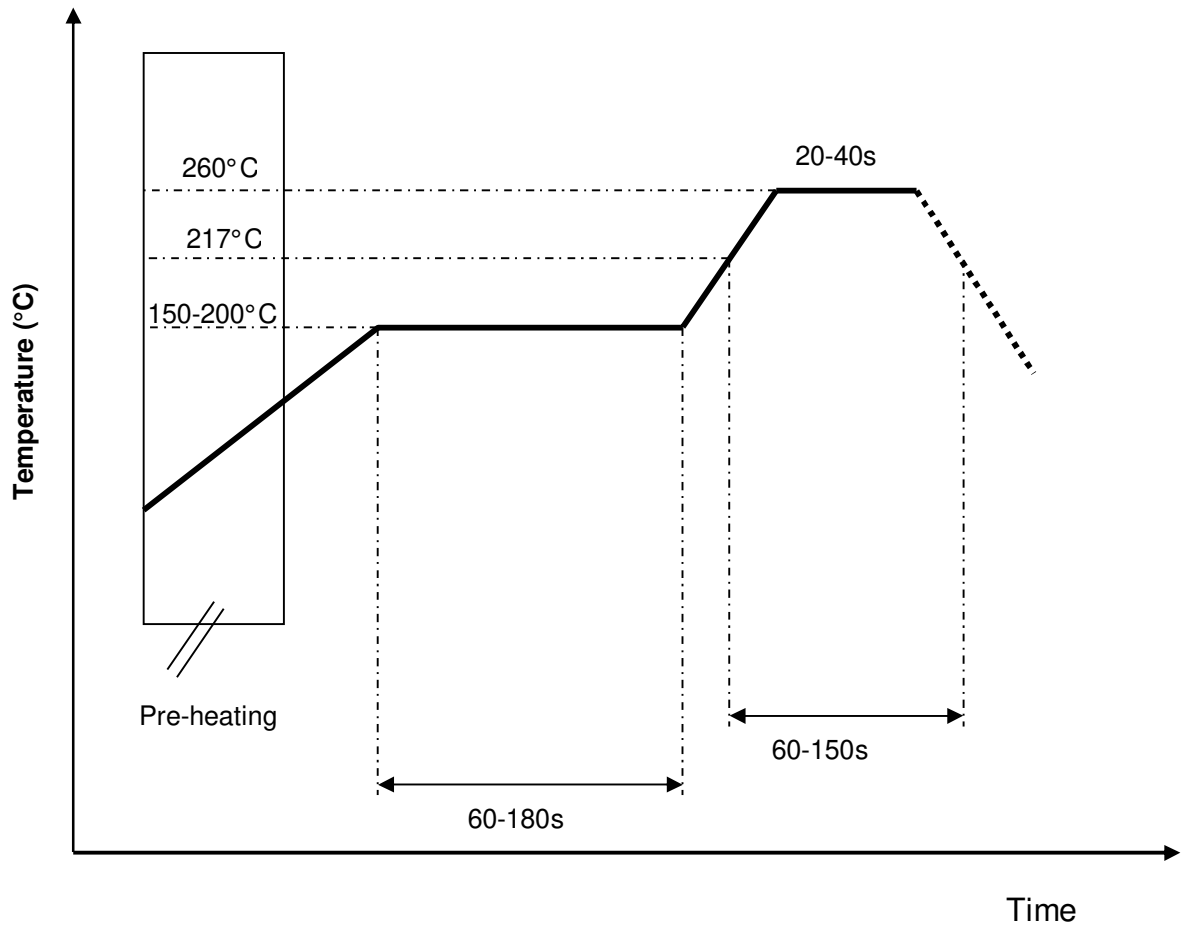

* Recommended solder paste alloy: SAC305 (Sn96.5 / Ag3 / Cu0.5) Lead Free solder paste



詠業科技股份有限公司
Unictron Technologies Corporation
Website: www.unictron.com

THIS DRAWINGS AND SPECIFICATIONS ARE THE PROPERTY OF UNICTRON TECHNOLOGIES CORPORATION AND SHALL NOT BE REPRODUCED OR USED AS THE BASIS FOR THE MANUFACTURE OR SALE OF APPARATUS OR DEVICES WITHOUT PERMISSION

Prepared by : **Wen** Designed by : **Peter** Checked by : **Mike** Approved by : **Herbert**

TITLE : 3.0 x 3.0 x 3.3 (mm) Bluetooth Chip PCB Substrate Antenna (EVB+CW337) Engineering Specification	DOCUMENT NO.	H2B1CB1A1B0100	REV.
			A

11. Operating & Storage Conditions

11-1. Operating

- (1) Maximum Input Power: 2 W
- (2) Operating Temperature: -40°C to 85°C
- (3) Relative Humidity: 10% to 70%

11-2. Storage (sealed)

- (1) Storage Temperature: -5°C to 40°C
- (2) Relative Humidity: 20% to 70%
- (3) Shelf Life: 1 year

12. Notice

(1) Installation Guide:

Please refer to Unictron's application note "General guidelines for the installation of Unictron's chip antennas" for further information.

(2) All specifications are subject to change without notice.



詠業科技股份有限公司
Unictron Technologies Corporation
Website: www.unictron.com

THIS DRAWINGS AND SPECIFICATIONS ARE THE PROPERTY OF UNICTRON TECHNOLOGIES CORPORATION AND SHALL NOT BE REPRODUCED OR USED AS THE BASIS FOR THE MANUFACTURE OR SALE OF APPARATUS OR DEVICES WITHOUT PERMISSION

Prepared by : **Wen**

Designed by : **Peter**

Checked by : **Mike**

Approved by : **Herbert**

**TITLE : 3.0 x 3.0 x 3.3 (mm) Bluetooth Chip PCB Substrate
Antenna (EVB+CW337) Engineering Specification**

**DOCUMENT
NO.**

H2B1CB1A1B0100

**REV.
A**