



## Evaluating the **ADP1872/ADP1873** PWM Buck Controllers

### FEATURES

- Wide power input voltage ( $V_{IN}$ ): 2.75 V to 20 V
- Bias supply voltage ( $V_{DD}$ ) range: 2.75 V to 5.5 V
- Available in 1.8 V fixed-output voltage
- Available in 300 kHz, 600 kHz, and 1.0 MHz switching frequency options
- Available in power saving mode (PSM) for light loads (**ADP1873** only)
- Starts into a precharged or preloaded output

### APPLICATIONS

- Perform basic evaluation board operations
- Evaluate IC and application board performance

### GENERAL DESCRIPTION

This document describes the evaluation board hardware for the **ADP1872/ADP1873** PWM buck controllers. The evaluation boards can be used to evaluate the **ADP1872** or **ADP1873** and application circuits using these ICs without requiring any additional software.

The **ADP1872/ADP1873** are versatile current-mode, synchronous step-down controllers that provide superior transient response, optimal stability, and current limit protection by using a constant on-time, pseudo-fixed frequency with a programmable current-sense gain, current-control scheme. The **ADP1873** is the power saving mode (PSM) version of the device and is capable of pulse skipping to maintain output regulation while achieving improved system efficiency at light loads (see the **ADP1872/ADP1873** data sheet for more information). Both devices are available in a small, 10-lead MSOP package and can operate over the  $-40^{\circ}\text{C}$  to  $+125^{\circ}\text{C}$  temperature range.

The **ADP1872/ADP1873** evaluation boards employ a power input voltage ( $V_{IN}$ ) that ranges between 2.75 V and 20 V and a bias supply voltage ( $V_{DD}$ ) that ranges between 2.75 V and 5.5 V. Both inputs can be tied together for application input voltage conditions equal to or less than 5.5 V. The evaluation board is available in a fixed-output voltage option ( $V_{OUT} = 1.8\text{ V}$ ), as well as in a 300 kHz, 600 kHz, or 1 MHz switching frequency (test trimmed in production). The **ADP1872/ADP1873** evaluation boards offer an output accuracy of 2% over the full temperature range and provide a high input voltage ( $V_{IN} \pm 10\%$ ) and a full-scale load current up to 15 A.

### TYPICAL APPLICATIONS CIRCUIT

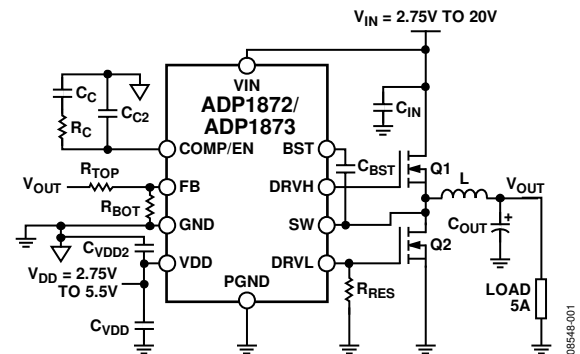

Figure 1.

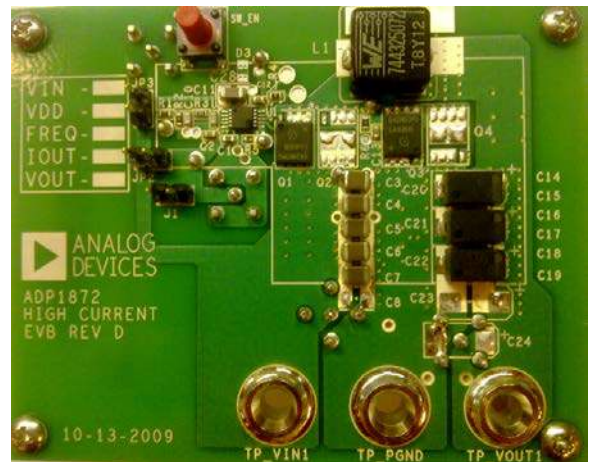

Figure 2. **ADP1872** Evaluation Board Configured for 300 kHz Switching Frequency Operation

The **ADP1872/ADP1873** data sheet provides more information, including details about how to modify the evaluation board while maintaining system stability throughout the entire load current range and, therefore, should be consulted in conjunction with this user guide when using the evaluation boards.

**TABLE OF CONTENTS**

Features .....	1	Typical Performance Characteristics .....	6
Applications.....	1	Typical Application Circuits .....	10
General Description .....	1	Dual-Input, 300 kHz High Current Application Circuit .....	10
Typical Applications Circuit.....	1	Evaluation Board Schematics and Layout.....	11
Revision History .....	2	1.8 V Output, 300 kHz, 14 A Application Circuit.....	11
Evaluation Board Hardware .....	3	Layer 1.....	12
Setting Up the Evaluation Board .....	3	Layer 2.....	13
Powering Up and Powering Down the Evaluation Board.....	4	Layer 3.....	14
Enabling and Disabling the ADP1872/ADP1873 .....	4	Layer 4.....	15
Evaluating the Performance of the ADP1872/ADP1873 .....	4	Bill of Materials.....	16
Modifying the Evaluation Board .....	5	1.8 V Output, 300 kHz, 14 A Application Circuit.....	16

**REVISION HISTORY**

**12/13—Rev. 0 to Rev. A**

Deleted 3.3 V Fixed-Output Voltage Model .....	Universal
Deleted Single-Input, 600 kHz Application Circuit Section	
and Figure 29.....	10
Updated ESD Caution and Legal Terms and Conditions .....	18

**3/10—Revision 0: Initial Version**

## EVALUATION BOARD HARDWARE

Upon receipt of the [ADP1872/ADP1873](#) evaluation board, the following criteria have already been determined:

- The IC is either the [ADP1872](#) (forced pulse-width modulation [PWM]) or the [ADP1873](#) (power saving mode [PSM]).
- The switching frequency is 300 kHz, 600 kHz, or 1 MHz.

### SETTING UP THE EVALUATION BOARD

Before powering up the system, set up the evaluation board as follows to ensure that all passive and active components are properly soldered to the evaluation board:

1. Ensure that the Headers JP2 and J1 connections are correct for a given application (see Table 1 and the Headers JP2 and J1 section).
2. Ensure that the main power supply ( $V_{IN}$ ) is off but set to 0 V, and then connect the main power supply to the evaluation board, connecting the positive terminal to TP\_VIN1 and the negative terminal to TP\_PGND.
3. Optionally, place a current meter in series with the main power supply to monitor the input current.
4. Ensure that the low input voltage supply ( $V_{DD}$ ) is off but set to 0 V, and then connect the low input voltage supply to the evaluation board, connecting the positive terminal to J1 and the negative terminal to TP\_PGND.
5. Ensure that the electronic load is turned off, and then connect the load to the evaluation board, connecting the positive terminal to TP\_VOUT1 and the negative terminal to TP\_PGND.
6. Optionally, connect a power resistor of the appropriate value for your application across the TP\_VOUT1 and TP\_PGND terminals of the evaluation board.
7. Optionally, to continually monitor  $V_{IN}$ ,  $V_{DD}$ , and  $V_{OUT}$ , solder SMB jacks to each of the following measuring points: VIN1, VOUT1, and VREG1 (see Figure 33).

**Table 1. Header Connections**

Header	Input Voltage (V)	Description of Connection
J1	≤5.5	Floating (no jumper), single input configuration.
	>5.5	Connect to $V_{DD}$ (dual input configuration), and, optionally, add a voltmeter across J1 and TP_PGND to monitor the low input voltage.
JP2	≤5.5	Jumper between $V_{IN}$ and $V_{DD}$ (single input configuration).
	>5.5	Open (no jumper), dual input configuration.
JP3	N/A	Jumper at all times.

#### Headers JP2 and J1

When the power input voltage is greater than 5.5 V, the device is in dual input configuration. If this configuration is chosen, ensure that Header JP2 is open (no jumper), and connect J1 to  $V_{DD}$ . Optionally, you can also add a voltmeter across J1 and TP\_PGND to monitor the low input voltage.

If the power input voltage is less than or equal to 5.5 V, the device is in single input configuration. In this case, a jumper can be placed on Header JP2 that connects  $V_{IN}$  to  $V_{DD}$ . If a jumper is used in this way, leave Header J1 floating (no jumper), and ensure that  $V_{IN}$  does not exceed 5.5 V.

#### Header JP3

Always put a jumper on Header JP3 to connect the high voltage input to Pin 1 ( $V_{IN}$ ) of the IC.

#### High Input Voltage Power Source ( $V_{IN}$ )

Ensure that the main power supply equipment is turned off but set to 0 V before connecting the main power supply to the evaluation board. Place a current meter in series with this power supply to monitor the input current. Connect the positive terminal (+) of the power supply to the TP\_VIN1 terminal of the evaluation board. Connect the negative terminal of the power supply (–) to the TP\_PGND terminal of the evaluation board.

#### Low Input Voltage Supply for Bias ( $V_{DD}$ )

Set the low input voltage supply to 0 V and make sure that it is turned off before connecting the positive terminal (+) to Jumper J1 of the evaluation board. Connect the negative terminal (–) to the TP\_PGND terminal of the evaluation board.

#### Output Terminal

The output terminal (TP\_VOUT1) of the [ADP1872/ADP1873](#) evaluation board is equipped with a banana terminal plug similar to TP\_VIN1 and TP\_PGND. The evaluation board is designed to withstand load immediately upon power-up, but may be damaged if the load is not properly connected to TP\_VOUT1. Ensure that the electronic load is turned off prior to connecting the positive terminal (+) and negative terminal (–) to the  $V_{OUT}$  and TP\_PGND terminals of the evaluation board, respectively. If a power resistor is used, connect this device across the TP\_VOUT1 and TP\_PGND terminals of the evaluation board.

Ensure that proper current values for your application are programmed on the electronic load prior to activation and, if applicable, that the correct power resistor value for your application is in place before powering up the evaluation board.

#### DC Voltmeter on $V_{IN}$ , $V_{DD}$ , and $V_{OUT}$

For more accurate dc measurements of  $V_{IN}$ ,  $V_{DD}$ , and  $V_{OUT}$ , add a dedicated voltmeter for each of these voltage nodes (resources permitting) to continually monitor  $V_{IN}$ ,  $V_{OUT}$ , and  $V_{DD}$ . This can be done by placing an SMB jack on VIN1, VOUT2, VREG1 (see Figure 33).

Placeholders for SMB jacks are integrated into each evaluation board to facilitate such connections. Therefore, to accurately measure  $V_{IN}$ , connect the voltmeter's positive terminal (+) to the node where the positive terminal of the high voltage input capacitors (C3 to C8) and the drain of Q1/Q2 meet, and connect the voltmeter's negative terminal (-) to the node where the negative terminal of the input capacitors and the source terminal of Q3 meet. These SMB terminals are optimally placed to minimize unnecessary voltage drops that may otherwise produce inaccurate  $V_{IN}$  dc measurements.

Similarly, for output voltage ( $V_{OUT}$ ) dc measurements, a placeholder for an SMB terminal is positioned directly across the positive and negative terminals of the output capacitor that is farthest from the inductor terminal and source of Q3. For accurate low input voltage ( $V_{DD}$ ) dc measurements, an SMB terminal footprint is positioned as close as possible across C1, which is laid out near the VDD pin (Pin 5) and the PGND pin (Pin 7) of the ADP1872/ADP1873.

## POWERING UP AND POWERING DOWN THE EVALUATION BOARD

After completing the procedure described in the Setting Up the Evaluation Board section, power up the evaluation board as follows:

1. Apply power to the VDD pin.
2. Apply power to the VIN pin.
3. Slowly increase the  $V_{DD}$  supply while monitoring the current meter until  $V_{DD}$  is equal to 5 V.  
Because  $V_{IN}$  is 0 V,  $I_{DD}$  should jump between 120  $\mu$ A (when approaching the UVLO threshold of 2.65 V) to less than 1 mA until  $V_{DD}$  is equal to 5 V. Do not exceed 5.5 V on  $V_{DD}$ . No output ( $V_{OUT}$ ) regulation is expected yet because  $V_{IN}$  is 0 V.
4. Slowly increase  $V_{IN}$  up to 12 V.  
When  $V_{IN}$  is increased,  $V_{OUT}$  begins regulating to the desired voltage setpoint (via the  $V_{OUT}$  dedicated voltmeter). Continue to increase  $V_{IN}$  up to 12 V. Do not exceed 20 V on  $V_{IN}$ . Output voltage regulation should occur regardless of whether there is a load connected at the output.
5. After the output voltage is in regulation with the desired input voltage, increase the electronic load to the desired value.

To power down the evaluation board,

1. Power down  $V_{IN}$ .
2. Power down  $V_{DD}$ .

## ENABLING AND DISABLING THE ADP1872/ADP1873

The ADP1872/ADP1873 evaluation board has a placeholder for a switch (normally open) for the COMP/EN pin to allow you to enable (open) and disable (closed) the ADP1872/ADP1873 on the evaluation board. When closed, the switch shorts this pin to ground, disabling the ADP1872/ADP1873. When the switch is subsequently opened (released), the error amplifier brings the

voltage on this pin above the enable threshold of 285 mV, thus enabling the IC, which causes the output voltage to regulate.

## EVALUATING THE PERFORMANCE OF THE ADP1872/ADP1873

### Verifying the Switching Waveform

To verify the switching waveform,

1. Ensure that the oscilloscope, probe tips, and ground loop clip are in good working condition; that the probe tips have been calibrated per the manufacturer's instructions and are clear of debris and dirt; and that the ground loops do not have any breaks or peels.
2. Set the operating mode of the respective oscilloscope to **DC Coupling** in the oscilloscope's **Channel** menu.
3. Set the bandwidth to its maximum value ( $\geq 150$  MHz).
4. Set the vertical scale to 5 V per division and the timescale (x-axis) to  $1/(2 \times f_{sw})$  per division, where  $f_{sw}$  is the switching frequency of the evaluation board.
5. Securely attach the ground loop clip onto the TP\_PGND terminal of the evaluation board. Ideally, the loop should be as close as possible to the negative terminal of the high input voltage capacitors (C3 to C8) and to the source of MOSFET Q1.
6. Land or securely attach the probe tip to the drain of Q1.
7. Observe the subsequent switching waveform and jitter.

The resultant switching waveform should be between 0 V and the value of  $V_{IN}$  (that is, 12 V), and the jitter should be less than or equal to 100 ns.

### Observing the Output Voltage Ripple

To observe the output voltage ripple,

1. Set the operating mode of the respective oscilloscope to **AC Coupling** in the oscilloscope's **Channel** menu.
2. Set the vertical scale to 100 mV per division and the timescale to  $1/(2 \times f_{sw})$ .
3. Securely attach the ground loop clip onto the TP\_PGND terminal of the evaluation board. Ideally, the loop should be as close as possible to the negative terminal (-) of the farthest output capacitor from the inductor terminal, and the probe tip should touch the positive terminal (+) of the same output capacitor.
4. Observe the output voltage ripple.

### Evaluating the Inductor Current Waveform

To evaluate the inductor current waveform,

1. Calibrate the current probe per the manufacturer's instructions.
2. Power up the system (see the Powering Up and Powering Down the Evaluation Board section).
3. Solder a 3 inch wire loop (from 10 gauge to 14 gauge) between the source of Q1 and the inductor terminal. The current probe has a clamping mechanism and can clamp onto this wire to measure the current traveling through the wire.

4. Ensure that the current direction is toward the output voltage (TP\_VOUT1) and that the clamp of the current probe is in the closed, or locked, position.
5. Set the vertical scale to one-third of the total load current that the converter is designed to deliver.
6. Set the timescale similar to how the switching and output ripple waveforms were set.
7. Observe the inductor current waveform.

### Obtaining Efficiency Measurements

To obtain more accurate efficiency measurements,

1. Power down the device.
2. Remove the 3 inch wire loop between the source of Q1 and the inductor terminal.
3. Power up the device.
4. Record the current and voltage readings.

Efficiency is calculated based on the measurements made between the output and the input of the converter:

$$\eta = \frac{V_{OUT} \times I_{OUT}}{V_{IN} \times I_{IN}}$$

where:

$V_{OUT}$  is the dc voltage readout by the voltmeter that is connected to the SMB terminal of the evaluation board or by the voltmeter that is connected across the output capacitor that is located farthest from the inductor terminal.

$I_{OUT}$  is the digital readout produced by the electronic load equipment.

$V_{IN}$  is the dc voltage readout by the voltmeter.

$I_{IN}$  is the current readout from the current meter in series between the high input voltage supply equipment and the TP\_VIN1 terminal of the evaluation board.

### Assessing Line Regulation

To assess the line regulation,

1. Vary the high input voltage.
2. Record the resultant changes on the dc level of the output voltage ( $V_{OUT}$ ).

### Examining Load Regulation

To examine the load regulation,

1. Vary the load current through electronic load adjustments.
2. Record the resultant changes on the dc level of the output voltage ( $V_{OUT}$ ).

### Observing Transient Response

To observe the transient response,

1. Power up the system (see the Powering Up and Powering Down the Evaluation Board section).
2. Solder a 3 inch wire loop (from 10 gauge to 14 gauge) between the source of Q1 and the inductor terminal.
3. Record instances where the output transient is out of phase with the load. Such occurrences are caused by sudden changes in the output load current and can be recorded by capturing the inductor ripple current waveform and the output voltage ac transient using the single acquisition feature of the oscilloscope.

### Evaluating Short-Circuit Protection

To evaluate the self-protection scheme of the ADP1873 during output short-circuit events,

1. Achieve steady state regulation.
2. Short the voltage output (TP\_VOUT1) to TP\_PGND.

The system then enters hiccup mode and remains in this mode until the violation disappears (see the ADP1872/ADP1873 data sheet for more details).

### MODIFYING THE EVALUATION BOARD

For any given ADP1872/ADP1873 evaluation board, an ADP1872 or ADP1873 IC can be used interchangeably as long as the pre-trimmed frequency setpoint is the same for both ICs.

To maintain system stability throughout the entire load current range, one component (passive or active) cannot be modified without modifying the rest. Refer to the ADP1872/ADP1873 data sheet for information about how each of the following elements can be adjusted, keeping in mind that any change affects the entire system:

- Feedback resistor divider
- Inductor
- Output capacitor
- Compensation network
  - Output filter impedance ( $Z_{FILT}$ )
  - Error amplifier output impedance ( $Z_{COMP}$ )
  - Error amplifier gain ( $G_M$ )
  - Current-sense loop gain ( $G_{CS}$ )
  - Programmable current-sense gain ( $A_{CS}$ )
  - Valley current limit setting
  - Crossover frequency

# TYPICAL PERFORMANCE CHARACTERISTICS

For the most up-to-date typical performance characteristics, see the [ADP1872/ADP1873](#) data sheet.

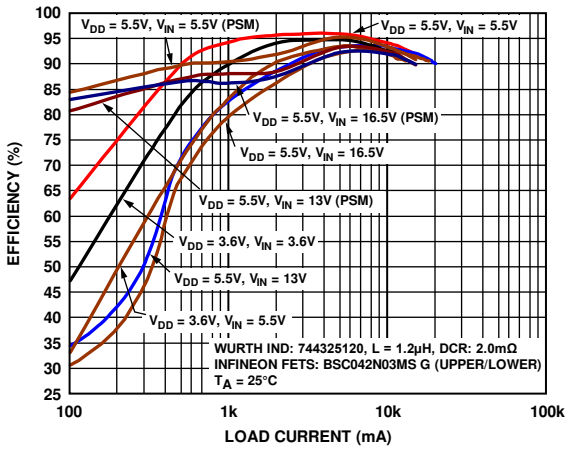

Figure 3. Efficiency—300 kHz,  $V_{OUT} = 1.8\text{ V}$

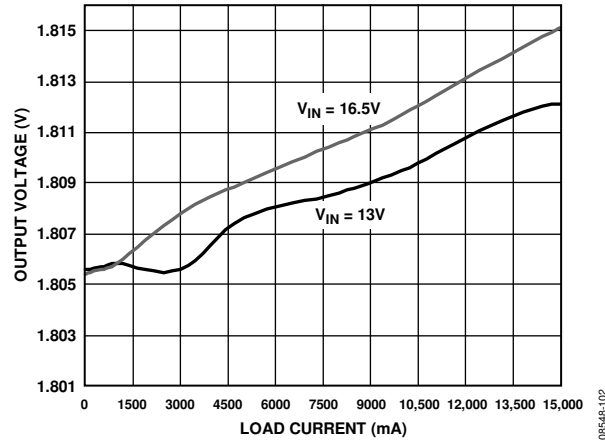

Figure 6. Load Regulation Plot for  $f_{SW} = 300\text{ kHz}$ ,  $V_{OUT} = 1.8\text{ V}$

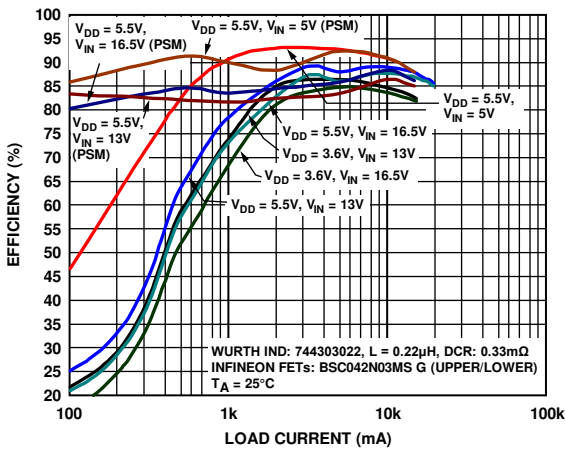

Figure 4. Efficiency—1 MHz,  $V_{OUT} = 1.8\text{ V}$

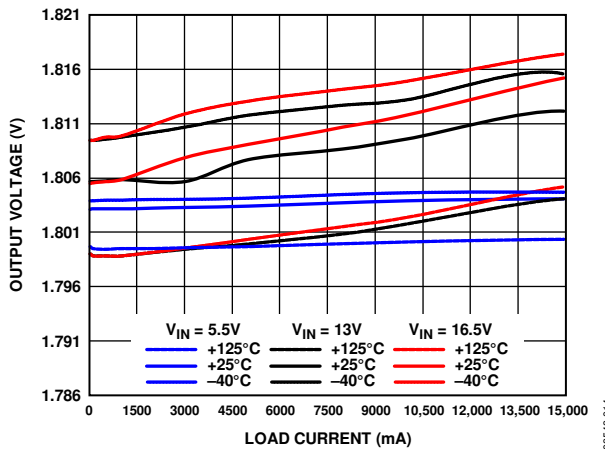

Figure 7. Output Voltage Accuracy—300 kHz,  $V_{OUT} = 1.8\text{ V}$

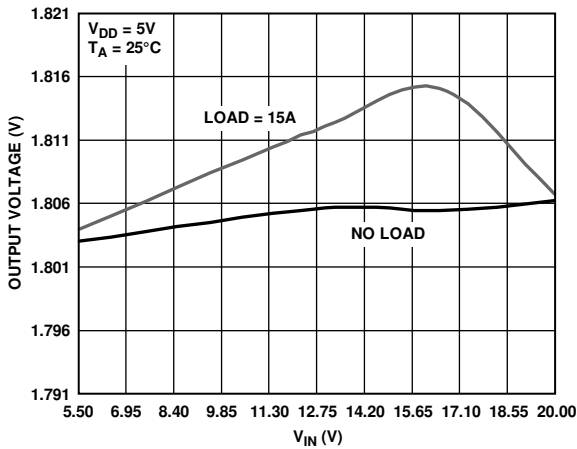

Figure 5. Line Regulation Plot for  $f_{SW} = 300\text{ kHz}$ ,  $V_{OUT} = 1.8\text{ V}$

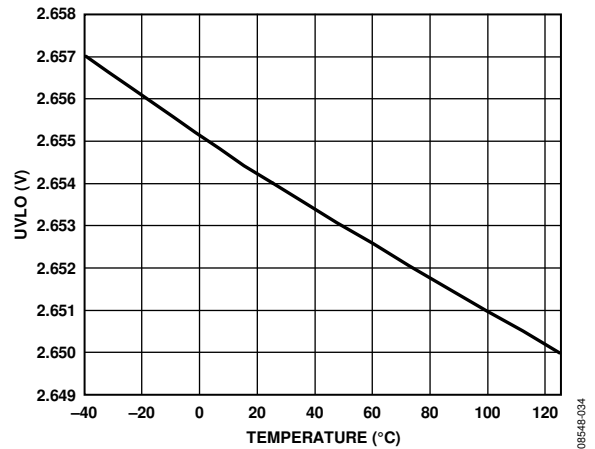

Figure 8. UVLO vs. Temperature



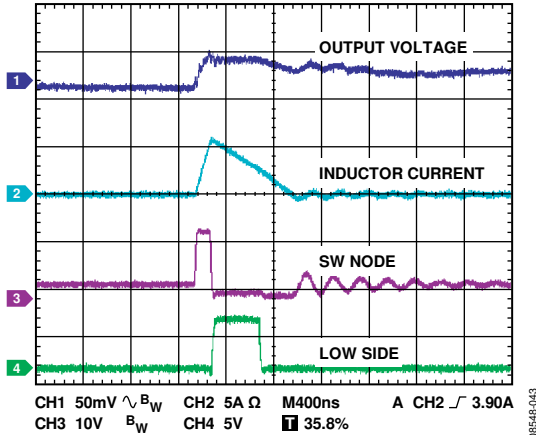

Figure 9. Power Saving Mode (PSM) Operational Waveform, 100 mA

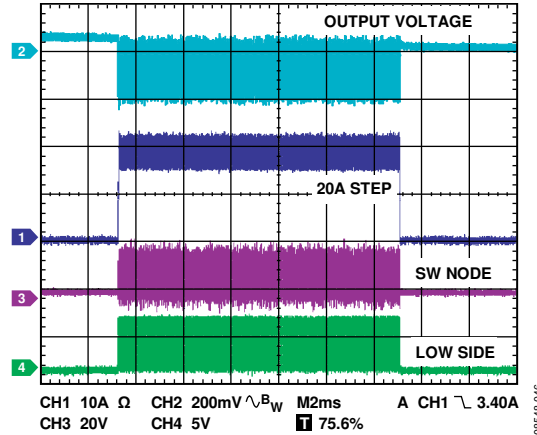

Figure 12. Load Transient Step—PSM Enabled, 20 A (See Figure 28 for Application Circuit)

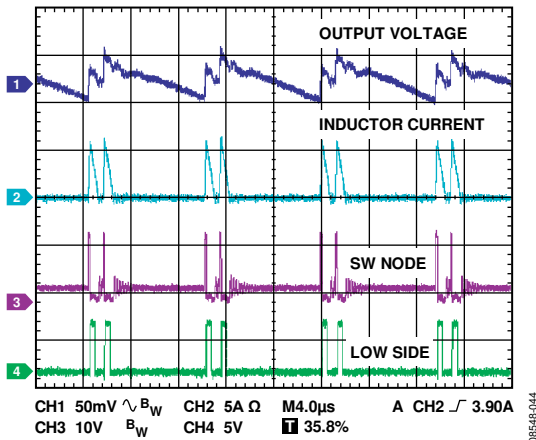

Figure 10. PSM Waveform at Light Load, 500 mA

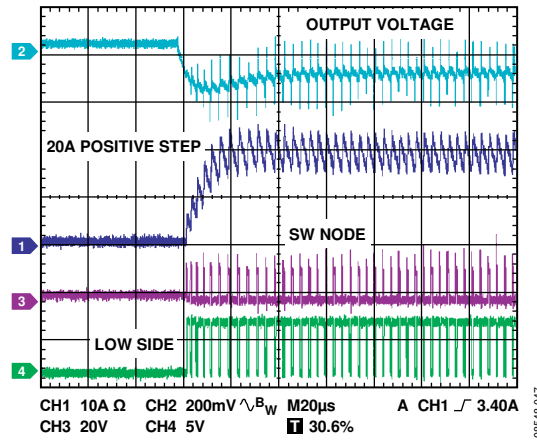

Figure 13. Positive Step During Heavy Load Transient Behavior—PSM Enabled, 20 A,  $V_{OUT} = 1.8 V$  (See Figure 28 for Application Circuit)

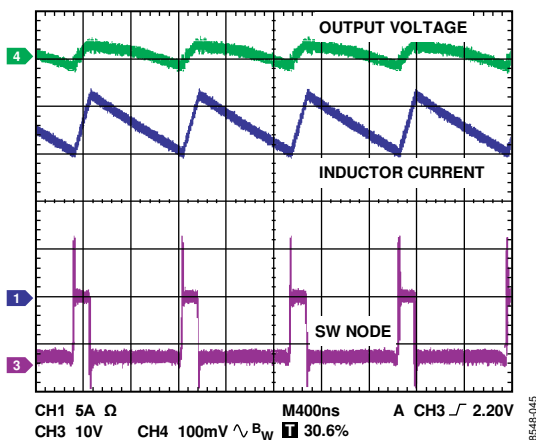

Figure 11. CCM Operation at Heavy Load, 18 A (See Figure 28 for Application Circuit)

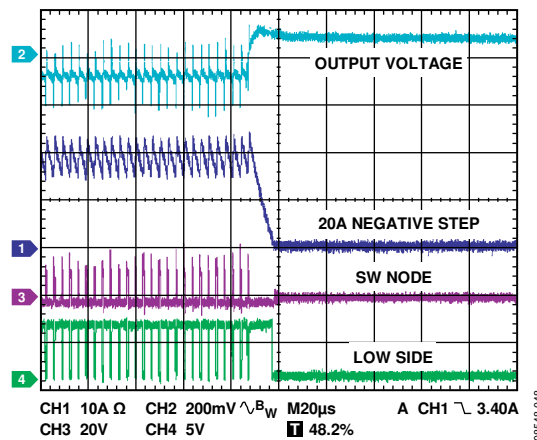

Figure 14. Negative Step During Heavy Load Transient Behavior—PSM Enabled, 20 A (See Figure 28 for Application Circuit)

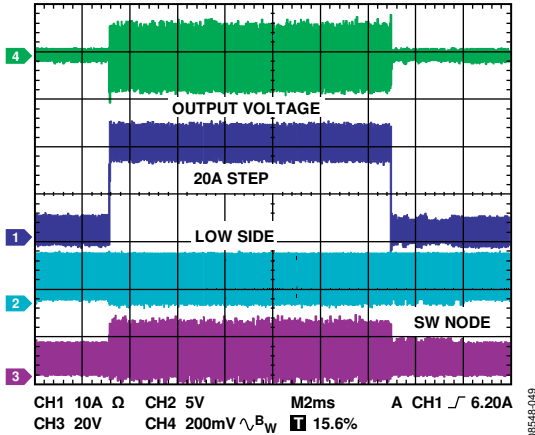

Figure 15. Load Transient Step—Forced PWM at Light Load, 20 A (See Figure 28 for Application Circuit)

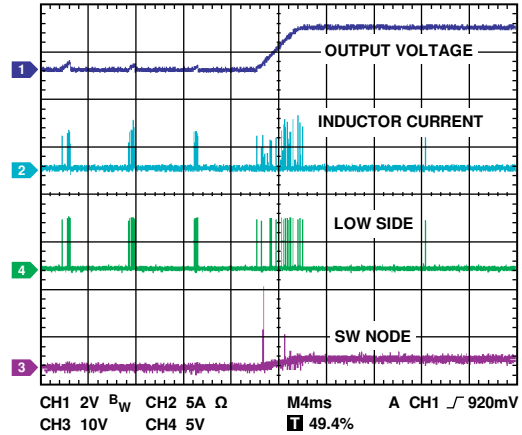

Figure 18. Output Short-Circuit Behavior Leading to Hiccup Mode

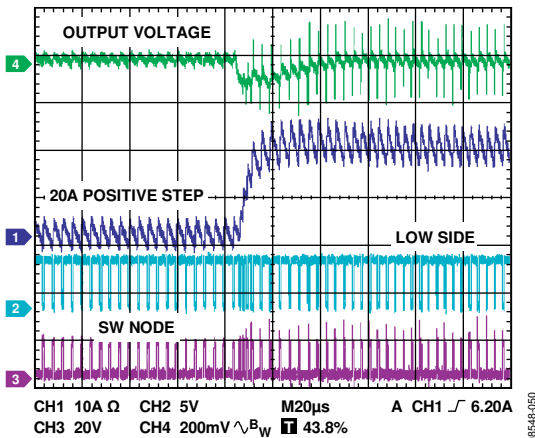

Figure 16. Positive Step During Heavy Load Transient Behavior—Forced PWM at Light Load, 20 A,  $V_{OUT} = 1.8V$  (See Figure 28 for Application Circuit)

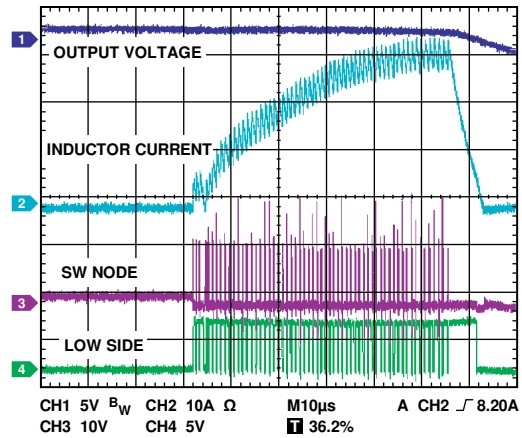

Figure 19. Magnified Waveform During Hiccup Mode

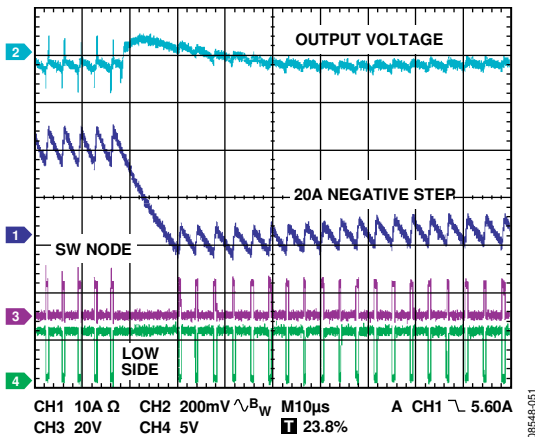

Figure 17. Negative Step During Heavy Load Transient Behavior—Forced PWM at Light Load, 20 A (See Figure 28 for Application Circuit)

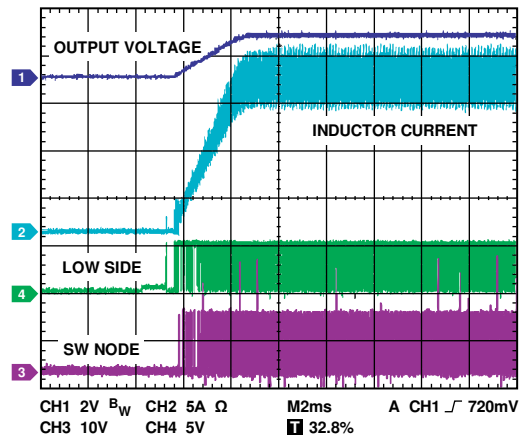

Figure 20. Start-Up Behavior at Heavy Load, 18 A, 300 kHz (See Figure 28 for Application Circuit)



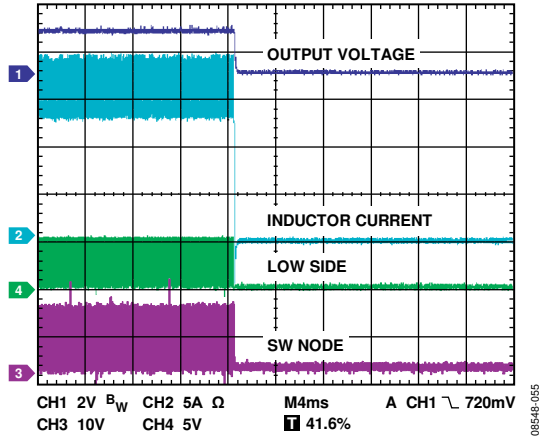

Figure 21. Power-Down Waveform During Heavy Load

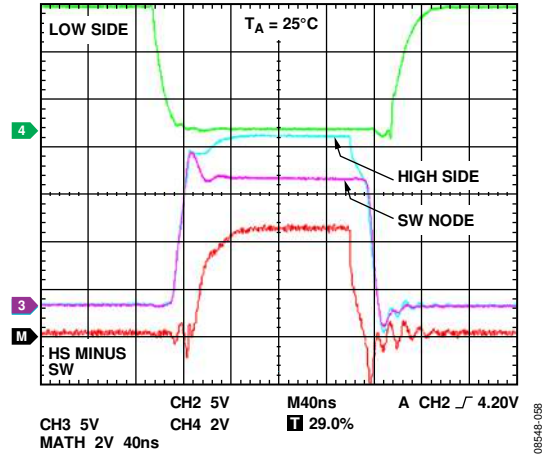

Figure 24. Output Drivers and SW Node Waveforms

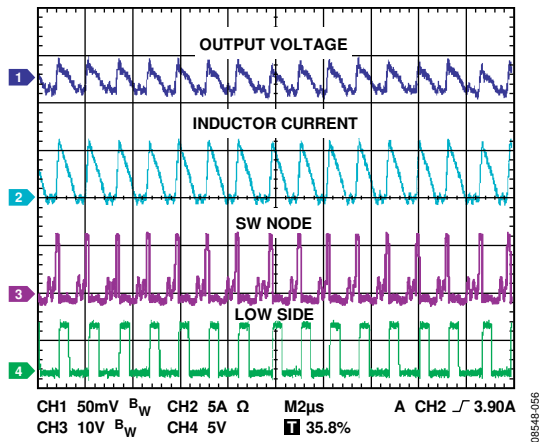

Figure 22. Output Voltage Ripple Waveform During PSM Operation at Light Load, 2 A

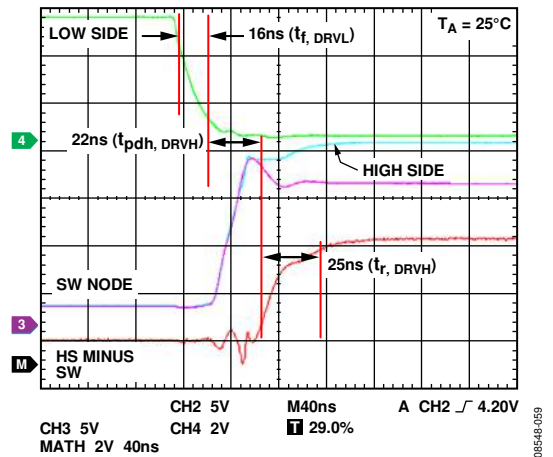

Figure 25. Upper-Side Driver Rising and Lower-Side Falling Edge Waveforms,  $C_{IN} = 4.3 \text{ nF}$  (Upper-/Lower-Side MOSFET),  $Q_{TOTAL} = 27 \text{ nC}$  ( $V_{GS} = 4.4 \text{ V}$  (Q1),  $V_{GS} = 5 \text{ V}$  (Q3))

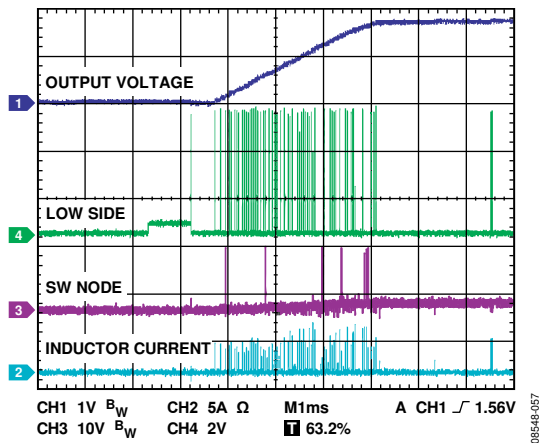

Figure 23. Soft Start and RES Detect Waveform

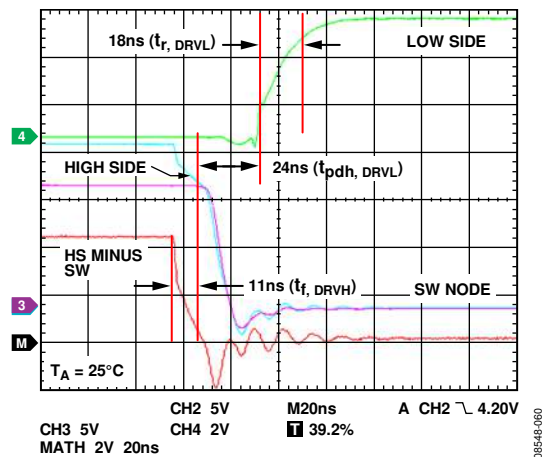

Figure 26. Upper-Side Driver Falling and Lower-Side Rising Edge Waveforms,  $C_{IN} = 4.3 \text{ nF}$  (Upper-/Lower-Side MOSFET),  $Q_{TOTAL} = 27 \text{ nC}$  ( $V_{GS} = 4.4 \text{ V}$  (Q1),  $V_{GS} = 5 \text{ V}$  (Q3))

# TYPICAL APPLICATION CIRCUITS

## DUAL-INPUT, 300 kHz HIGH CURRENT APPLICATION CIRCUIT

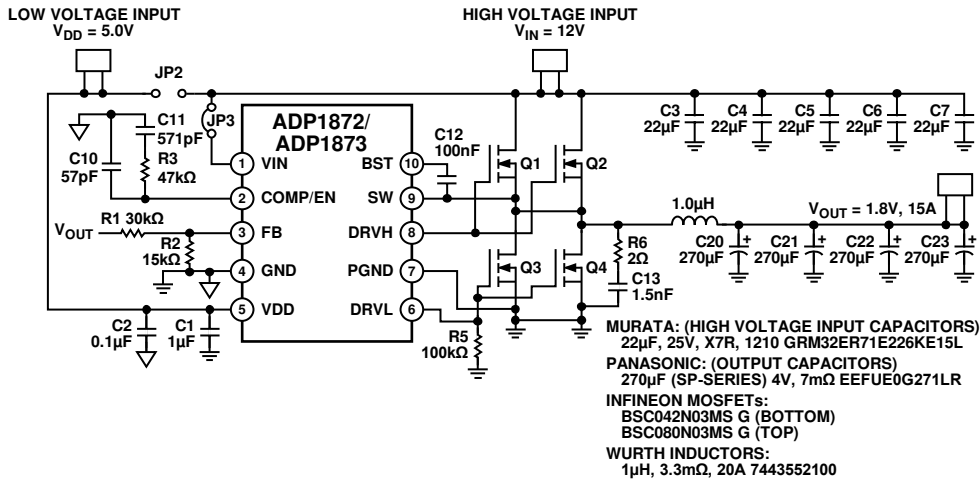

Figure 27. Application Circuit for 12 V Input, 1.8 V Output, 15 A, 300 kHz (Q2/Q4 No Connect)

08548-088

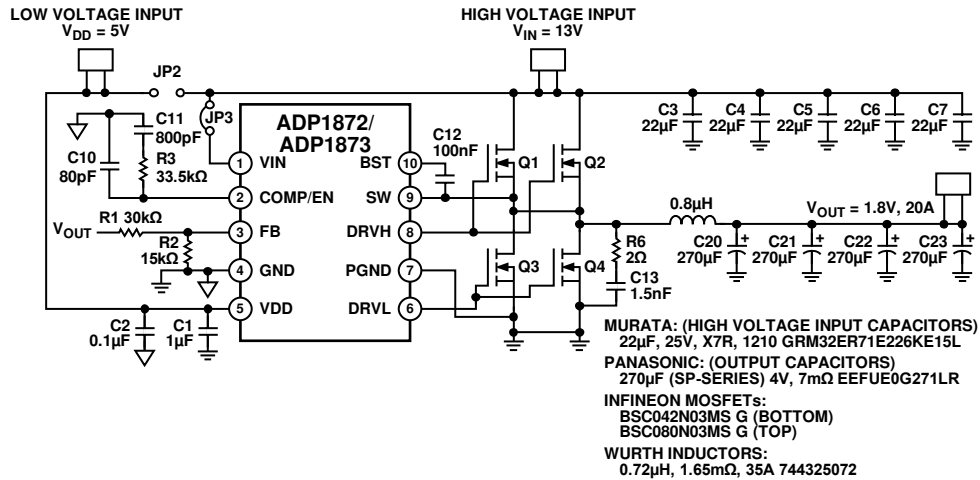

Figure 28. Application Circuit for 13 V Input, 1.8 V Output, 20 A, 300 kHz (Q2/Q4 No Connect)

08548-080

## EVALUATION BOARD SCHEMATICS AND LAYOUT

This section provides the schematics for the 1.8 V output, 300 kHz, 14 A application circuit. For other application circuits, see the [ADP1872/ADP1873](#) data sheet for the recommended values for the external components.

### 1.8 V OUTPUT, 300 kHz, 14 A APPLICATION CIRCUIT

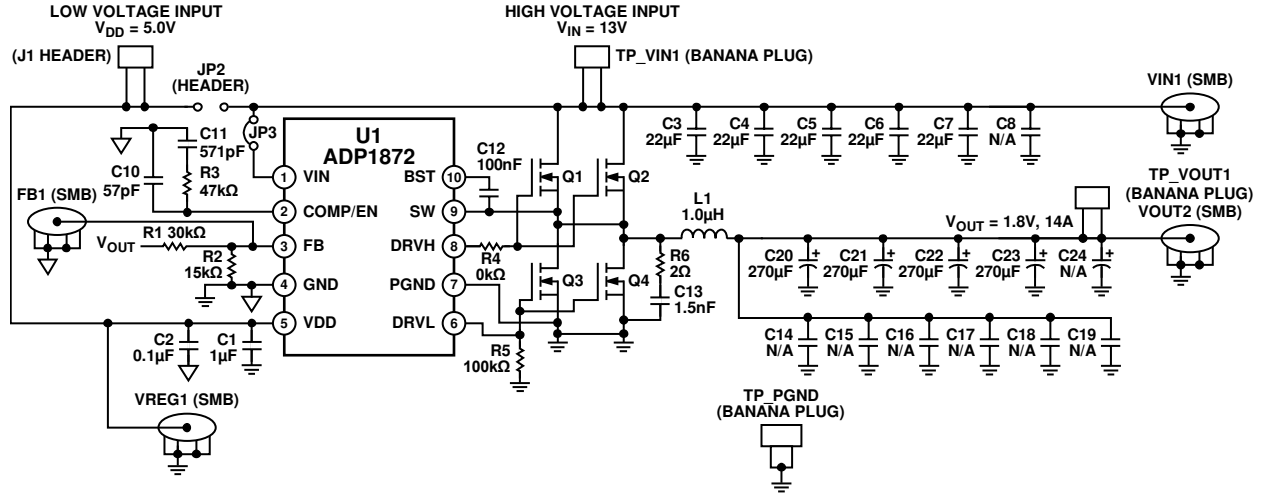

Figure 29. 1.8 V Output, 300 kHz, 14 A Application Circuit

09548-103

LAYER 1

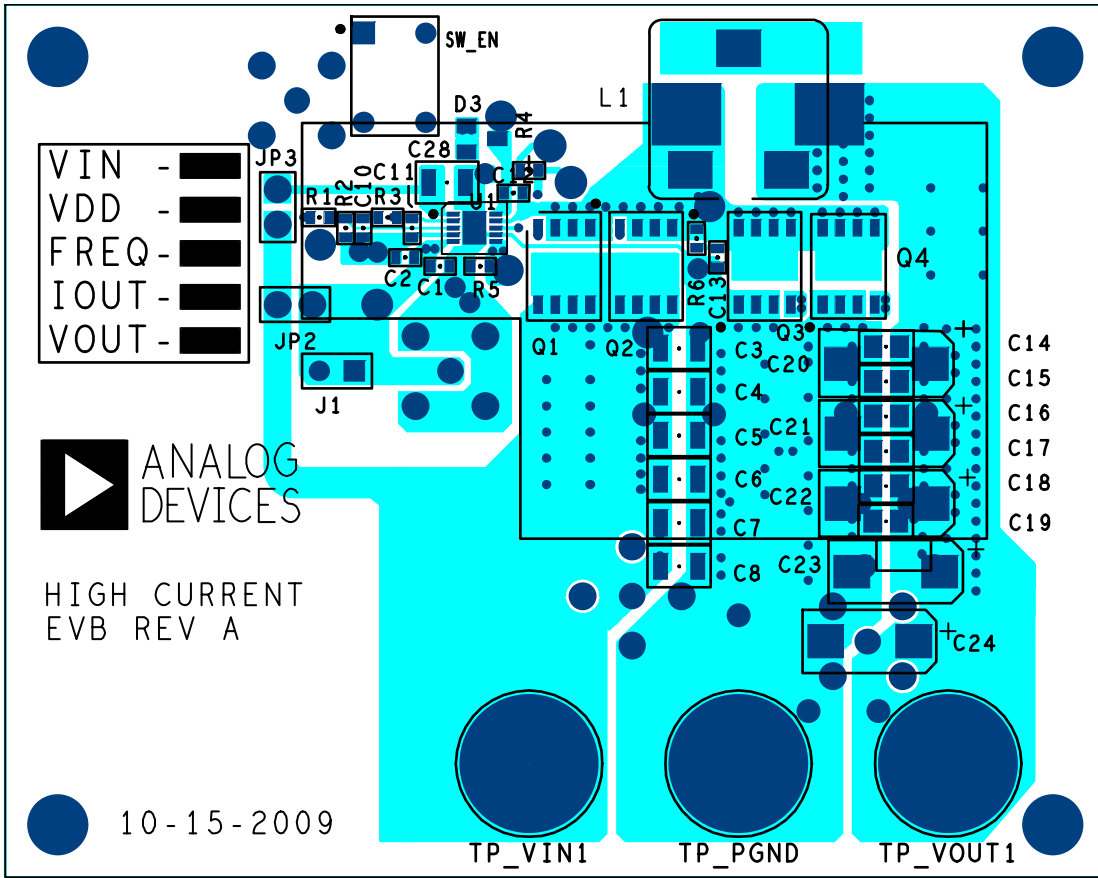

Figure 30. Layer 1

LAYER 2

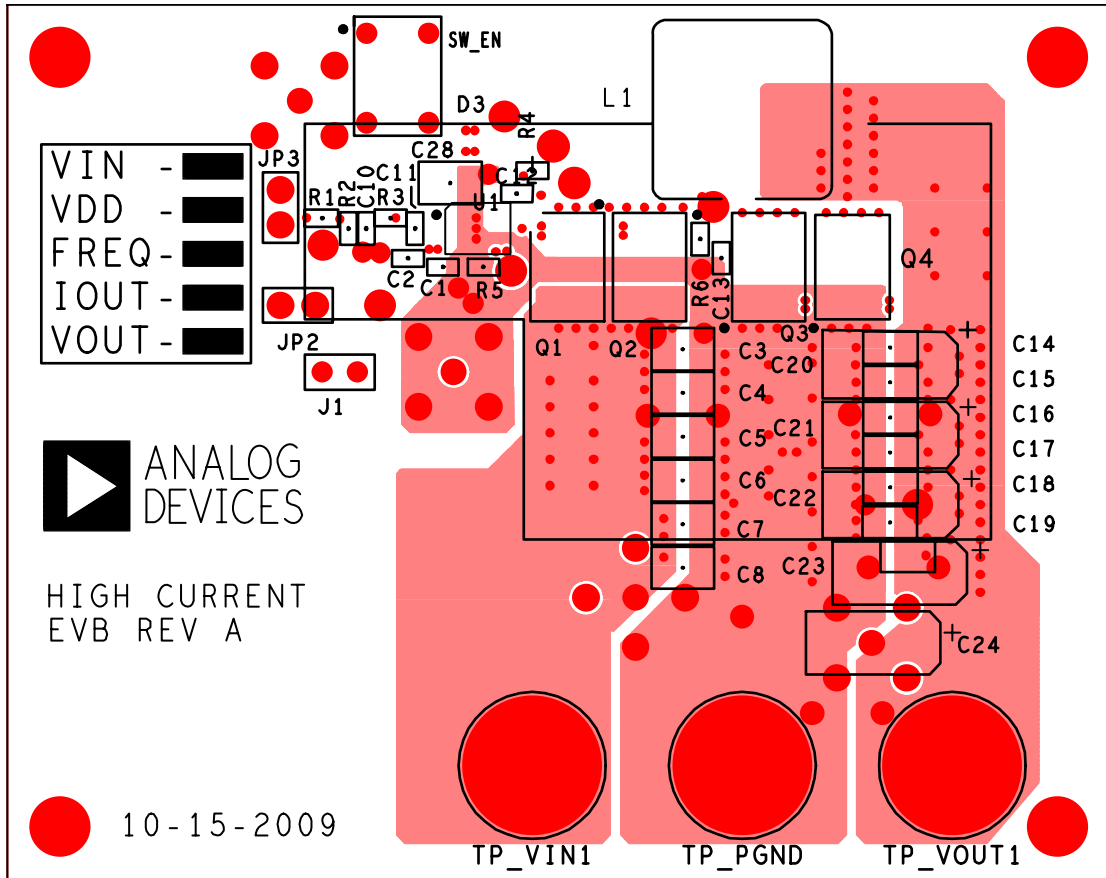

Figure 31. Layer 2

0854P-083

LAYER 3

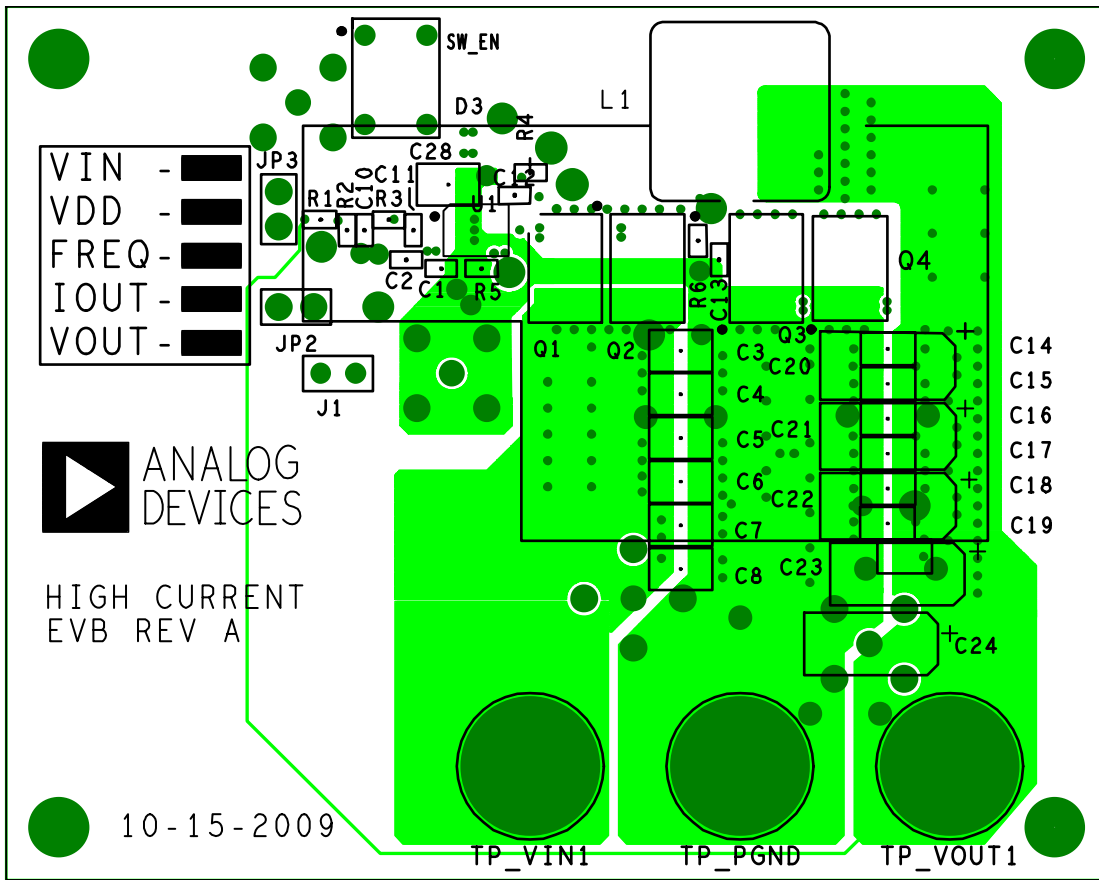

Figure 32. Layer 3



LAYER 4

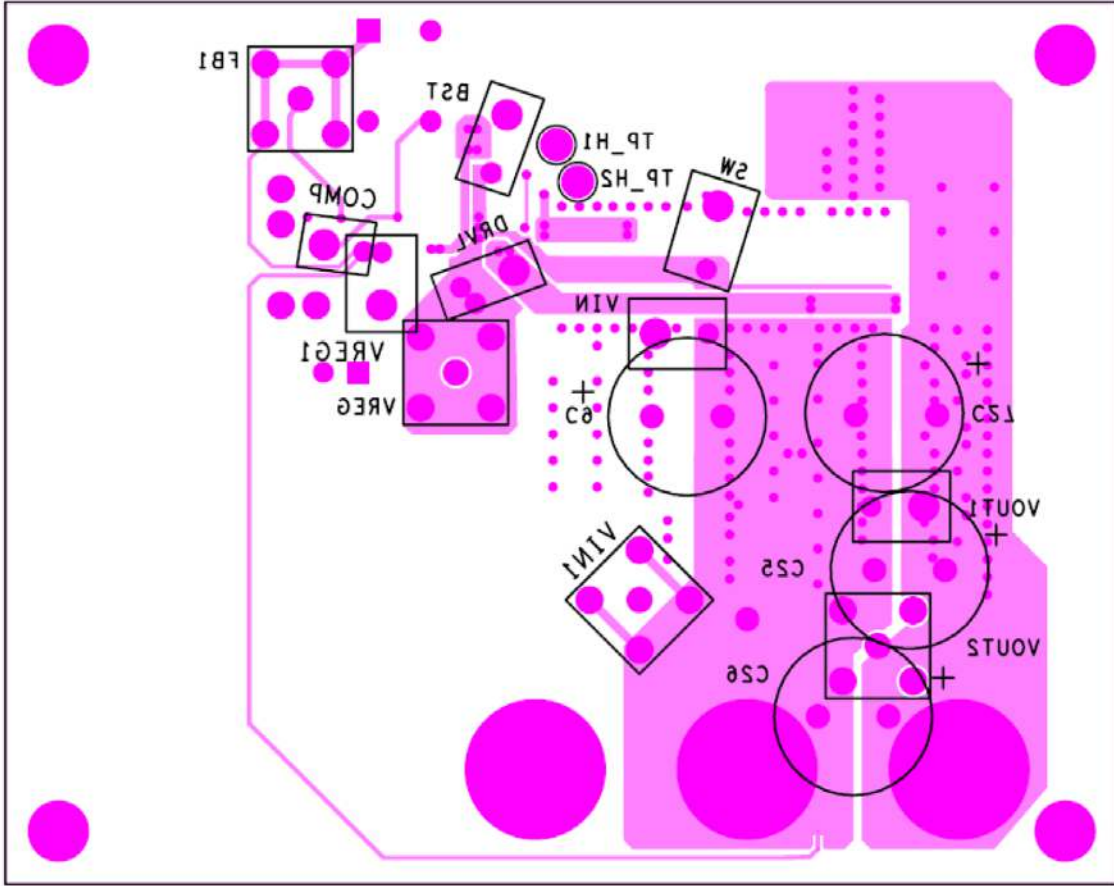

Figure 33. Layer 4

08548-085

## BILL OF MATERIALS

## 1.8 V OUTPUT, 300 kHz, 14 A APPLICATION CIRCUIT

Table 2.

Name	Reference Designator	Value	Unit	Manufacturer	Description/Model
C <sub>VDD</sub>	C1	1.0	μF	Taiyo Yuden	1.0 μF, 6.3 V, X5R ceramic capacitor (0402), JMK105BJ105KV-F
C <sub>VDD</sub>	C2	0.1	μF	TDK	0.1 μF, 25 V, X5R ceramic capacitor (0402), C1005X5R1E104K
C <sub>IN</sub>	C3	22	μF	Murata	25 V, X7R, 1210 (3.2 mm × 2.5 mm × 2.5 mm) GRM32ER71E226KE15L
C <sub>IN</sub>	C4	22	μF	Murata	25 V, X7R, 1210 (3.2 mm × 2.5 mm × 2.5 mm) GRM32ER71E226KE15L
C <sub>IN</sub>	C5	22	μF	Murata	25 V, X7R, 1210 (3.2 mm × 2.5 mm × 2.5 mm) GRM32ER71E226KE15L
C <sub>IN</sub>	C6	22	μF	Murata	25 V, X7R, 1210 (3.2 mm × 2.5 mm × 2.5 mm) GRM32ER71E226KE15L
C <sub>IN</sub>	C7	22	μF	Murata	25 V, X7R, 1210 (3.2 mm × 2.5 mm × 2.5 mm) GRM32ER71E226KE15L
C <sub>IN</sub>	C8	N/A	N/A		
C <sub>PAR</sub>	C10	57	pF	Taiyo Yuden <sup>1</sup>	±10%, 50 V, X7R ceramic capacitor (0402)
C <sub>c</sub>	C11	571	pF	Taiyo Yuden <sup>1</sup>	±5%, 50 V, C0H ceramic capacitor (0402)
C <sub>BST</sub>	C12	100	nF	Taiyo Yuden <sup>1</sup>	±10%, 50 V, X7R ceramic capacitors (0603)
C <sub>SNUBBER</sub>	C13	1.5	nF	Taiyo Yuden <sup>1</sup>	±10%, 50 V, X7R ceramic capacitors (0603)
C <sub>OUT</sub>	C14	N/A	N/A		
C <sub>OUT</sub>	C15	N/A	N/A		
C <sub>OUT</sub>	C16	N/A	N/A		
C <sub>OUT</sub>	C17	N/A	N/A		
C <sub>OUT</sub>	C18	N/A	N/A		
C <sub>OUT</sub>	C19	N/A	N/A		
C <sub>OUT</sub>	C20	270	μF	Panasonic	SP-series, 4 V, 7 mΩ, 3.7 A EEFUE0G271LR (4.3 mm × 7.3 mm × 4.2 mm)
C <sub>OUT</sub>	C21	270	μF	Panasonic	SP-series, 4 V, 7 mΩ, 3.7 A EEFUE0G271LR (4.3 mm × 7.3 mm × 4.2 mm)
C <sub>OUT</sub>	C22	270	μF	Panasonic	SP-series, 4 V, 7 mΩ, 3.7 A EEFUE0G271LR (4.3 mm × 7.3 mm × 4.2 mm)
C <sub>OUT</sub>	C23	270	μF	Panasonic	SP-series, 4 V, 7 mΩ, 3.7 A EEFUE0G271LR (4.3 mm × 7.3 mm × 4.2 mm)
C <sub>OUT</sub>	C24	N/A	N/A		
R <sub>TOP</sub>	R1	30	kΩ	Vishay <sup>1</sup>	±1% resistors (0603)
R <sub>BOT</sub>	R2	15	kΩ	Vishay <sup>1</sup>	±1% resistors (0603)
R <sub>c</sub>	R3	47	kΩ	Vishay <sup>1</sup>	±1% resistors (0603)
R <sub>GATE</sub>	R4	0	kΩ	Vishay <sup>1</sup>	±1% resistors (0603)
R <sub>RES</sub>	R5	100	kΩ	Vishay <sup>1</sup>	±1% resistors (0603)
R <sub>SNUBBER</sub>	R6	2	Ω	Vishay <sup>1</sup>	±1% resistors (0603)
Top MOSFET	Q1	N/A	N/A	Infineon	BSC080N03MS G
Top MOSFET	Q2	N/A	N/A	Infineon	BSC080N03MS G
Bottom MOSFET	Q3	N/A	N/A	Infineon	BSC080N03MS G
Bottom MOSFET	Q4	N/A	N/A	Infineon	BSC080N03MS G
Inductor	L1	1.0	μH	Würth Elek	7443251200
Header	J1	N/A	N/A		
Header	JP2	N/A	N/A		
Header	JP3	N/A	N/A		
Banana Plugs	TP_VIN1	N/A	N/A		
Banana Plugs	TP_PGND	N/A	N/A		
Banana Plugs	TP_VOUT1	N/A	N/A		
Controller/Driver	U1	N/A	N/A	Analog Devices	ADP1872ARMZ-0.3-R7 <sup>2</sup> (LDT) or ADP1873ARMZ-0.3-R7 <sup>2</sup> (LDF)
Diode	D3	N/A	N/A		

<sup>1</sup> Components from other manufacturers can also be used, as long as the characteristics listed in the corresponding description are met.<sup>2</sup> Z = RoHS Compliant Part.

## NOTES

**NOTES**

## NOTES

## NOTES

**ESD Caution**

**ESD (electrostatic discharge) sensitive device.** Charged devices and circuit boards can discharge without detection. Although this product features patented or proprietary protection circuitry, damage may occur on devices subjected to high energy ESD. Therefore, proper ESD precautions should be taken to avoid performance degradation or loss of functionality.

**Legal Terms and Conditions**

By using the evaluation board discussed herein (together with any tools, components documentation or support materials, the "Evaluation Board"), you are agreeing to be bound by the terms and conditions set forth below ("Agreement") unless you have purchased the Evaluation Board, in which case the Analog Devices Standard Terms and Conditions of Sale shall govern. Do not use the Evaluation Board until you have read and agreed to the Agreement. Your use of the Evaluation Board shall signify your acceptance of the Agreement. This Agreement is made by and between you ("Customer") and Analog Devices, Inc. ("ADI"), with its principal place of business at One Technology Way, Norwood, MA 02062, USA. Subject to the terms and conditions of the Agreement, ADI hereby grants to Customer a free, limited, personal, temporary, non-exclusive, non-sublicensable, non-transferable license to use the Evaluation Board FOR EVALUATION PURPOSES ONLY. Customer understands and agrees that the Evaluation Board is provided for the sole and exclusive purpose referenced above, and agrees not to use the Evaluation Board for any other purpose. Furthermore, the license granted is expressly made subject to the following additional limitations: Customer shall not (i) rent, lease, display, sell, transfer, assign, sublicense, or distribute the Evaluation Board; and (ii) permit any Third Party to access the Evaluation Board. As used herein, the term "Third Party" includes any entity other than ADI, Customer, their employees, affiliates and in-house consultants. The Evaluation Board is NOT sold to Customer; all rights not expressly granted herein, including ownership of the Evaluation Board, are reserved by ADI. CONFIDENTIALITY. This Agreement and the Evaluation Board shall all be considered the confidential and proprietary information of ADI. Customer may not disclose or transfer any portion of the Evaluation Board to any other party for any reason. Upon discontinuation of use of the Evaluation Board or termination of this Agreement, Customer agrees to promptly return the Evaluation Board to ADI. ADDITIONAL RESTRICTIONS. Customer may not disassemble, decompile or reverse engineer chips on the Evaluation Board. Customer shall inform ADI of any occurred damages or any modifications or alterations it makes to the Evaluation Board, including but not limited to soldering or any other activity that affects the material content of the Evaluation Board. Modifications to the Evaluation Board must comply with applicable law, including but not limited to the RoHS Directive. TERMINATION. ADI may terminate this Agreement at any time upon giving written notice to Customer. Customer agrees to return to ADI the Evaluation Board at that time. LIMITATION OF LIABILITY. THE EVALUATION BOARD PROVIDED HEREUNDER IS PROVIDED "AS IS" AND ADI MAKES NO WARRANTIES OR REPRESENTATIONS OF ANY KIND WITH RESPECT TO IT. ADI SPECIFICALLY DISCLAIMS ANY REPRESENTATIONS, ENDORSEMENTS, GUARANTEES, OR WARRANTIES, EXPRESS OR IMPLIED, RELATED TO THE EVALUATION BOARD INCLUDING, BUT NOT LIMITED TO, THE IMPLIED WARRANTY OF MERCHANTABILITY, TITLE, FITNESS FOR A PARTICULAR PURPOSE OR NONINFRINGEMENT OF INTELLECTUAL PROPERTY RIGHTS. IN NO EVENT WILL ADI AND ITS LICENSORS BE LIABLE FOR ANY INCIDENTAL, SPECIAL, INDIRECT, OR CONSEQUENTIAL DAMAGES RESULTING FROM CUSTOMER'S POSSESSION OR USE OF THE EVALUATION BOARD, INCLUDING BUT NOT LIMITED TO LOST PROFITS, DELAY COSTS, LABOR COSTS OR LOSS OF GOODWILL. ADI'S TOTAL LIABILITY FROM ANY AND ALL CAUSES SHALL BE LIMITED TO THE AMOUNT OF ONE HUNDRED US DOLLARS (\$100.00). EXPORT. Customer agrees that it will not directly or indirectly export the Evaluation Board to another country, and that it will comply with all applicable United States federal laws and regulations relating to exports. GOVERNING LAW. This Agreement shall be governed by and construed in accordance with the substantive laws of the Commonwealth of Massachusetts (excluding conflict of law rules). Any legal action regarding this Agreement will be heard in the state or federal courts having jurisdiction in Suffolk County, Massachusetts, and Customer hereby submits to the personal jurisdiction and venue of such courts. The United Nations Convention on Contracts for the International Sale of Goods shall not apply to this Agreement and is expressly disclaimed.