

6 dBi Omni Antenna 698-960 MHz, N Type Female
Fiberglass Radome, 2:1 Max VSWR



Antennas Technical Data Sheet

PE51OM1034

Features

- All weather operation
- Includes heavy duty steel mast mounting brackets
- Lightweight fiberglass radome
- Integral N-Female connector
- Rugged industrial grade design
- 360° Omnidirectional Pattern
- 4 to 6 dBi gain

Applications

- Supports lowband LTE and 5G networks
- Point to Multipoint and Non Line of Sight (NLOS)
- Applications
- 600, 700, 800 Cellular Band Operation

Description

The PE51OM1034 from Pasternack is a high performance 5G / LTE outdoor omnidirectional antenna designed for Cellular Networks. The PE51OM1034 operates from 698 to 960 MHz which is ideal for 5G, LTE, CDMA, LPWAN/IoT/ M2M applications including LoRA, LTE-M, and NB-IOT. The Multi-Band design of the Pasternack PE51OM1034 antenna eliminates the need to purchase different antennas for each frequency. The same antenna can be used for a wide array of base station cellular applications where wide coverage is desired. Pasternacks PE51OM1034 can be used to distribute Cellular telecommunication signals over a large area.

The omnidirectional antenna with vertical polarization PE51OM1034 from Pasternack has Type N connectors and 4-6 dBi of gain. The Type N connectorized PE51OM1034 antenna from Pasternack excels in large open areas. The mounting bracket and hardware are included for easy installation. Our Pasternack ISO 9001:2008 registered facilities in Irvine, CA ships all Type N RF, microwave and millimeter wave waveguide components from stock the same day you purchase them. Pasternack offers the broadest and deepest in-stock inventory and is where to buy 5G antennas. Our expert technical support and friendly, knowledgeable customer service personnel are available to assist you with your particular needs for 5G / LTE outdoor omnidirectional 5G cellular antennas.

Configuration

Design	Omni
Band Type	Single
Radiation Pattern	Omnidirectional
Polarization	Vertical
Connector Type	N Female
Number of Ports	1

Electrical Specifications

Description	Minimum	Typical	Maximum	Units
Frequency Range	698		960	MHz
Input VSWR			2:1	
Impedance		50		Ohms
Gain		6		dBi
Input Power			200	Watts

Click the following link (or enter part number in "SEARCH" on website) to obtain additional part information including price, inventory and certifications: [6 dBi Omni Antenna 698-960 MHz, N Type Female Fiberglass Radome, 2:1 Max VSWR PE51OM1034](#)

6 dBi Omni Antenna 698-960 MHz, N Type Female
Fiberglass Radome, 2:1 Max VSWR



Antennas Technical Data Sheet

PE510M1034

Mechanical Specifications

Radome Material	Fiberglass
Size	
Overall Length	42.8 in [108.71 cm]
Width	2.3 in [58.42 mm]
Height	2.3 in [58.42 mm]
Mounting Mast Diameter	1.18 to 2.36 in [29.97 to 59.94 mm]
Weight	3.3 lbs [1.5 kg]

Environmental Specifications

Temperature	
Operating Range	-40 to +70 deg C
Wind Loading	124.27 MPH [199.99 KPH]
Humidity	91

Compliance Certifications (see [product page](#) for current document)

Plotted and Other Data

Notes:

6 dBi Omni Antenna 698-960 MHz, N Type Female Fiberglass Radome, 2:1 Max VSWR from Pasternack Enterprises has same day shipment for domestic and International orders. Our RF, microwave and millimeter wave products maintain a 99.4% availability and are part of the broadest selection in the industry.

Click the following link (or enter part number in "SEARCH" on website) to obtain additional part information including price, inventory and certifications: [6 dBi Omni Antenna 698-960 MHz, N Type Female Fiberglass Radome, 2:1 Max VSWR PE510M1034](#)

URL: <https://www.pasternack.com/6-dbi-omni-antenna-698-960-mhz-n-type-female-2-1-max-vswr-pe51om1034-p.aspx>

The information contained in this document is accurate to the best of our knowledge and representative of the part described herein. It may be necessary to make modifications to the part and/or the documentation of the part, in order to implement improvements. Pasternack reserves the right to make such changes as required. Unless otherwise stated, all specifications are nominal. Pasternack does not make any representation or warranty regarding the suitability of the part described herein for any particular purpose, and Pasternack does not assume any liability arising out of the use of any part or documentation.

PE510M1034 CAD Drawing

6 dBi Omni Antenna 698-960 MHz, N Type Female Fiberglass Radome, 2:1 Max VSWR

REVISIONS			
REV.	DESCRIPTION	DATE	APPROVED
A	INITIAL RELEASE	05/17/2021	KHIETPAS

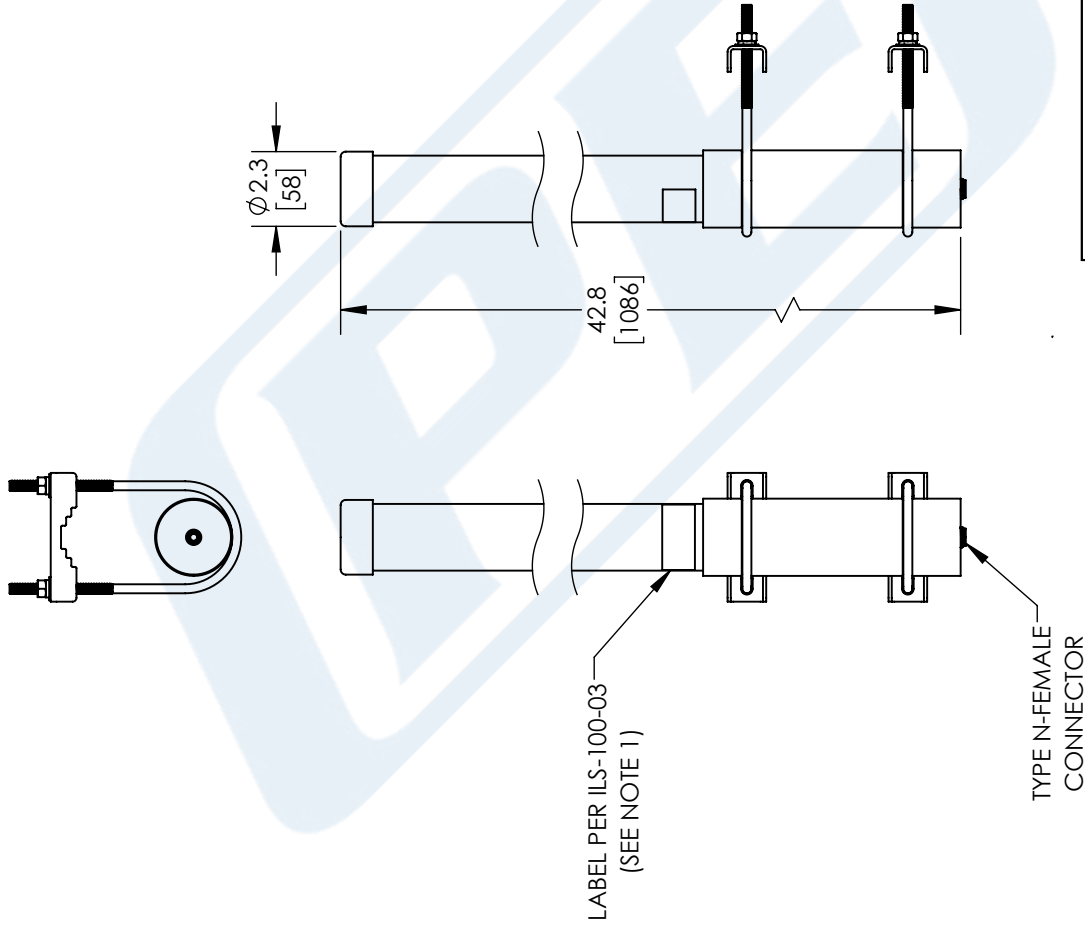

NOTES:
 1. LABEL PER ILS-100-03 (FOR INTERNAL REFERENCE ONLY)
 LABEL LOCATION FOR REFERENCE ONLY

UNLESS OTHERWISE SPECIFIED LEADING DIMENSIONS ARE INCHES DIMENSIONS IN [] ARE MILLIMETERS

TOLERANCES:
 .X = ±.2 [.508] FRACTIONS ± 1/32
 .XX = ±.02 [.51] ANGLES ± 1°
 .XXX = ±.005 [.13]

CABLE LENGTH (L) TOLERANCES:
 L ≤ 12 [305] = +1 [25] / -0
 12 [305] < L ≤ 60 [1524] = +2 [51] / -0
 60 [1524] < L ≤ 120 [3048] = +4 [102] / -0
 120 [3048] < L ≤ 300 [7620] = +6 [152] / -0
 300 [7620] < L = +5% / -0

ALL DIMENSIONS SHOWN ARE FOR REFERENCE ONLY.

PE PASTERNAK
 an INFINITI® brand

Pasternack Enterprises, Inc.
 P. O. Box 16759, Irvine, CA 92623.
 Phone: 1.949.261.1920 | 1.866.727.8376
 Fax: 1.949.261.7451
 Website: www.pasternack.com
 E-mail: sales@pasternack.com

SIZE: A CAGE CODE: 53919 DRAWN BY: BPUCHASKI ITEM NO.: PE510M1034

THIRD-ANGLE PROJECTION

THE INFORMATION AND DESIGN IN THIS DOCUMENT IS THE PROPERTY OF PASTERNAK CORPORATION ALL RIGHTS RESERVED.

SHEET 1 OF 1

SCALE: N/A

REV: A

THESE COMMODITIES, TECHNOLOGY OR SOFTWARE WERE EXPORTED FROM THE UNITED STATES IN ACCORDANCE WITH THE EXPORT ADMINISTRATION REGULATIONS. DIVERSION CONTRARY TO U.S. LAW PROHIBITED.