

STRUCTURE	Silicon Monolithic Integrated Circuit
NAME OF PRODUCT	DC-AC Inverter Control IC
TYPE	BD9890F
FUNCTION	<ul style="list-style-type: none"> ▪ 2ch control with Push-Pull ▪ Lamp current and voltage sense feed back control ▪ Sequencing easily achieved with Soft Start Control ▪ Short circuit protection with Timer Latch ▪ Under Voltage Lock Out ▪ Short circuit protection with over voltage ▪ Mode-selectable the operating or stand-by mode by stand-by pin ▪ Synchronous operating the other BD9890F or BD9890FV IC's ▪ BURST mode controlled by PWM and DC input ▪ 2ch in-phase in BURST mode

○Absolute Maximum Ratings (Ta = 25°C)

Parameter	Symbol	Limits	Unit
Supply Voltage	Vcc	15	V
Operating Temperature Range	Topr	-40~+90	°C
Storage Temperature Range	Tstg	-55~+125	°C
Power Dissipation	Pd	600*1 (BD9890F)	mW
		850*2 (BD9890FV)	
Maximum Junction Temperature	Tjmax	+125	°C

*1Pd derate at 6.0mW/°C for temperature above Ta = 25°C (When mounted on a PCB 70.0mm×70.0mm×1.6mm)

*2Pd derate at 8.5mW/°C for temperature above Ta = 25°C (When mounted on a PCB 70.0mm×70.0mm×1.6mm)

○Recommended operating condition

Parameter	Symbol	Limits	Unit
Supply voltage	VCC	5.0~14.0	V
CT oscillation frequency	fCT	20~150	kHz
BCT oscillation frequency	fBCT	0.05~0.50	kHz

Status of this document

The Japanese version of this document is the official specification.

Please use the translation version of this document as a reference to expedite understanding of the official version.

If there are any uncertainty in translation version of this document, official version takes priority.

○Electric Characteristics (Ta=25°C, VCC=7V)

Parameter	Symbol	Limits			Unit	Conditions
		MIN.	TYP.	MAX.		
((WHOLE DEVICE))						
Operating current	Icc1	—	11.0	17.0	mA	CT=0.5V
Stand-by current	Icc2	—	2	10	μA	
((OVER VOLTAGE DETECT))						
FB over voltage detect voltage	Vovf	2.20	2.40	2.60	V	
((STAND BY CONTROL))						
Stand-by voltage H	VstH	1.6	—	Vcc	V	System ON
Stand-by voltage L	VstL	-0.3	—	0.8	V	System OFF
Stand-by hysteresis	ΔVst	0.08	0.18	0.28	V	
((TIMER LATCH))						
Timer Latch voltage	Vcp	1.9	2.0	2.1	V	
Timer Latch current	Icp	0.5	1.0	1.5	μA	
((BURST MODE))						
BOSC Max voltage	VburH	1.94	2.0	2.06	V	fBCT=0.2kHz
BOSC Min Voltage	VburL	0.4	0.5	0.6	V	fBCT=0.2kHz
BOSC constant current	IBCT	1.35/BRT	1.5/BRT	1.65/BRT	A	
BOSC frequency	fBOSC	266	280	294	Hz	BRT=33kΩ, BCT=0.050μF
((OSC BLOCK))						
OSC constant current	ICT	1.35/RT	1.5/RT	1.65/RT	A	
OSC Max voltage	Vosch	1.8	2.0	2.2	V	fct=60kHz
OSC Min voltage	Voscl	0.3	0.5	0.7	V	fct=60kHz
MAX DUTY	MAXDUTY	44	46.5	49	%	fct=60kHz
Soft start current	Iss	1.0	2.0	3.0	μA	
IS COMP detect Voltage	Visc	0.45	0.50	0.55	V	
SS COMP detect voltage	Vss	2.0	2.2	2.4	V	
SRT ON resistance	RsRT	—	200	400	Ω	
((UVLO BLOCK))						
Operating voltage	VuvloH	4.100	4.300	4.500	V	
Shut down voltage	VuvloL	3.900	4.100	4.300	V	
Operating voltage (External UVLO)	Vuvlo1	2.160	2.220	2.280	V	
Lock out voltage (External UVLO)	Vuvlo2	2.242	2.315	2.388	V	
Hysteresis width	ΔVuvlo	0.068	0.095	0.122	V	
((REG BLOCK))						
REG output voltage	VREG	3.038	3.100	3.162	V	
REG source current	I _{REG}	5.0	—	—	mA	
VREF voltage	Vref1	1.225	1.250	1.275	V	VREF=OPEN
VREF input voltage range	Vref2	0.60	—	1.50	V	VREF applying voltage
((FEED BACK BLOCK))						
IS threshold voltage 1	Vis1	1.225	1.250	1.275	V	VREF=OPEN
IS threshold voltage 2	Vis2	—	Vref2	—	V	VREF applying voltage
VS threshold voltage	Vvs	1.220	1.250	1.280	V	
IS source current 1	Iis1	—	—	1.5	μA	DUTY=2.0V
IS source current 2	Iis2	13.0	20.0	27.0	μA	DUTY=0V, IS=0.5V
VS source current	Ivs	—	—	1.0	μA	
((OUTPUT BLOCK))						
NAch output voltage H	VoutNAH	Vcc-0.3	Vcc-0.1	—	V	
NBch output voltage H	VoutNBH	Vcc-0.3	Vcc-0.1	—	V	
NAch output voltage L	VoutNAL	—	0.1	0.3	V	
NBch output voltage L	VoutNBL	—	0.1	0.3	V	
NAch output sink resistance	RsinkNA	—	5	10	Ω	I _{sink} = 10mA
NAch output source resistance	RsourceNA	—	8	16	Ω	I _{source} = 10mA
NBch output sink resistance	RsinkNB	—	5	10	Ω	I _{sink} = 10mA
NBch output source resistance	RsourceNB	—	8	16	Ω	I _{source} = 10mA
Drive output frequency	fOUT	58.5	60.0	61.5	KHz	RT=18kΩ, CT=400pF
((COMP BLOCK))						
Under voltage detect	Vcompl	0.620	0.640	0.660	V	
((PROTECT CLOCK))						
Normal output voltage	VPH	2.9	3.1	3.3	V	
Protect output voltage	VPL	—	—	0.5	V	

(This product is not designed to be radiation-resistant.)

○Package Dimensions

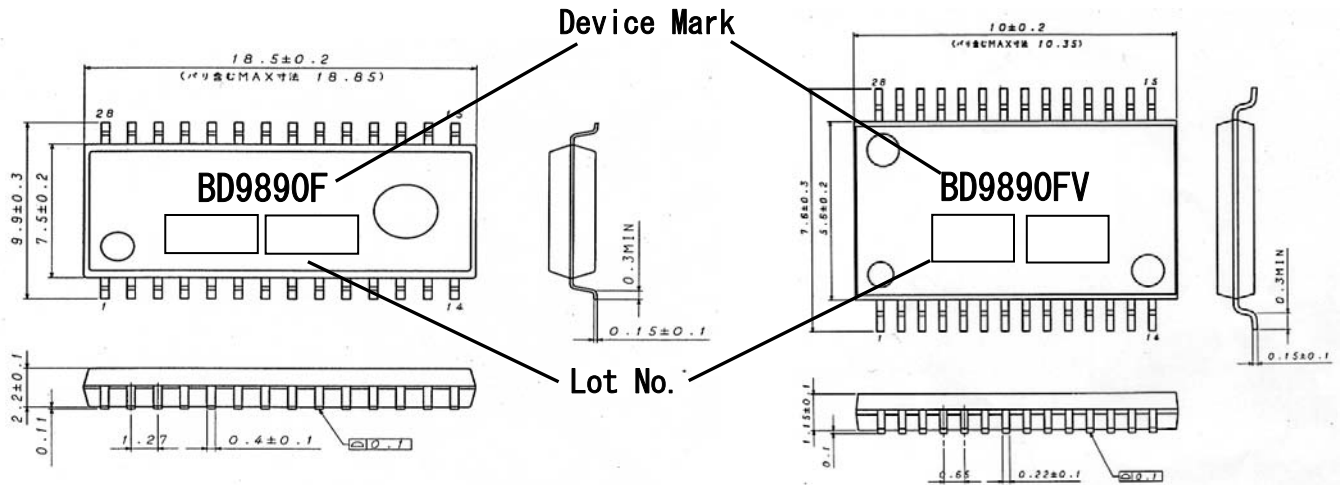

SOP28 (unit:mm)

SSOP-B28 (unit:mm)

○Block Diagram

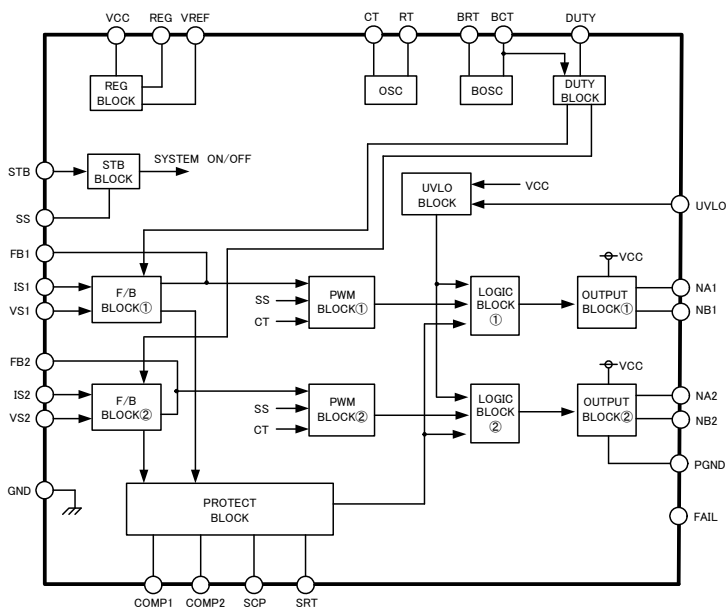

○Pin Description

Pin No.	Pin Name	Function
1	DUTY	Control PWM mode and BURST mode
2	BRT	External resistor from BRT to GND for adjusting the BURST triangle oscillator
3	BCT	External capacitor from BCT to GND for adjusting the BURST triangle oscillator
4	RT	External resistor from SRT to RT for adjusting the triangle oscillator
5	SRT	External resistor from SRT to RT for adjusting the triangle oscillator
6	CT	External capacitor from CT to GND for adjusting the triangle oscillator
7	GND	GROUND
8	FB1	Error amplifier output①
9	IS1	Error amplifier input①
10	VS1	Error amplifier input②
11	FB2	Error amplifier output②
12	IS2	Error amplifier input③
13	VS2	Error amplifier input④
14	VREF	Reference voltage
15	FAIL	Protect clock output
16	STB	Stand-by switch
17	COMP1	Under voltage detect for 1ch
18	COMP2	Under voltage detect for 2ch
19	UVLO	External Under Voltage Lock OUT
20	REG	Internal regulator output
21	SS	External capacitor from SS to GND for Soft Start Control
22	SCP	External capacitor from SCP to GND for Timer Latch
23	NA2	FET driver for 2ch
24	NB2	FET driver for 2ch
25	PGND	Ground for FET drivers
26	NB1	FET driver for 1ch
27	NA1	FET driver for 1ch
28	Vcc	Supply voltage input

○NOTE FOR USE

1. When designing the external circuit, including adequate margins for variation between external devices and IC. Use adequate margins for steady state and transient characteristics.
2. The circuit functionality is guaranteed within of ambient temperature operation range as long as it is within recommended operating range. The standard electrical characteristic values cannot be guaranteed at other voltages in the operating ranges, however the variation will be small.
3. Mounting failures, such as misdirection or miscounts, may harm the device.
4. A strong electromagnetic field may cause the IC to malfunction.
5. The GND pin should be the location within $\pm 0.3V$ compared with the PGND pin.
6. BD9890F and BD9890FV incorporate a built-in thermal shutdown circuit (TSD circuit). The thermal shutdown circuit (TSD circuit) is designed only to shut the IC off to prevent runaway thermal operation. It is not designed to protect the IC or guarantee its operation of the thermal shutdown circuit is assumed.
7. Absolute maximum ratings are those values that, if exceeded, may cause the life of a device to become significantly shortened. Moreover, the exact failure mode caused by short or open is not defined. Physical countermeasures, such as a fuse, need to be considered when using a device beyond its maximum ratings.
8. About the external FET, the parasitic Capacitor may cause the gate voltage to change, when the drain voltage is switching. Make sure to leave adequate margin for this IC variation.
9. On operating Slow Start Control (SS is less than 2.2V), It does not operate Timer Latch.
10. By STB voltage, BD9890F and BD9890FV are changed to 2 states. Therefore, do not input STB pin voltage between one state and the other state (0.8~1.6).

11. The pin connected a connector need to connect to the resistor for electrical surge destruction. This IC is a monolithic IC which (as shown is Fig-1) has P⁺ substrate and between the various pins. A P-N junction is formed from this P layer of each pin. For example, the relation between each potential is as follows,

- (When GND > PinB and GND > PinA, the P-N junction operates as a parasitic diode.)
- (When PinB > GND > PinA, the P-N junction operates as a parasitic transistor.)

Parasitic diodes can occur inevitably in the structure of the IC. The operation of parasitic diodes can result in mutual interference among circuits as well as operation faults and physical damage. Accordingly you must not use methods by which parasitic diodes operate, such as applying a voltage that is lower than the GND (P substrate) voltage to an input pin.

12. This IC is a monolithic IC which (as shown is Fig-1)has P⁺ substrate and between the various pins. A P-N junction is formed from this P layer of each pin. For example, the relation between each potential is as follows,

- (When GND > PinB and GND > PinA, the P-N junction operates as a parasitic diode.)
- (When PinB > GND > PinA, the P-N junction operates as a parasitic transistor.)

Parasitic diodes can occur inevitably in the structure of the IC. The operation of parasitic diodes can result in mutual interference among circuits as well as operation faults and physical damage. Accordingly you must not use methods by which parasitic diodes operate, such as applying a voltage that is lower than the GND (P substrate) voltage to an input pin.

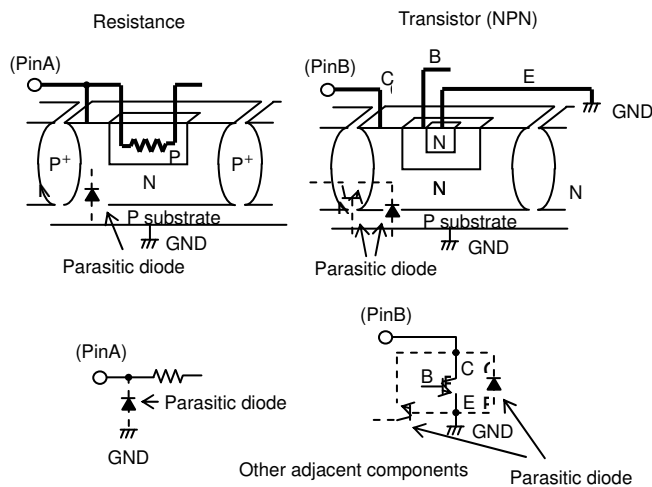

Fig-1 Simplified structure of a Bipolar IC

Notes

No copying or reproduction of this document, in part or in whole, is permitted without the consent of ROHM Co.,Ltd.

The content specified herein is subject to change for improvement without notice.

The content specified herein is for the purpose of introducing ROHM's products (hereinafter "Products"). If you wish to use any such Product, please be sure to refer to the specifications, which can be obtained from ROHM upon request.

Examples of application circuits, circuit constants and any other information contained herein illustrate the standard usage and operations of the Products. The peripheral conditions must be taken into account when designing circuits for mass production.

Great care was taken in ensuring the accuracy of the information specified in this document. However, should you incur any damage arising from any inaccuracy or misprint of such information, ROHM shall bear no responsibility for such damage.

The technical information specified herein is intended only to show the typical functions of and examples of application circuits for the Products. ROHM does not grant you, explicitly or implicitly, any license to use or exercise intellectual property or other rights held by ROHM and other parties. ROHM shall bear no responsibility whatsoever for any dispute arising from the use of such technical information.

The Products specified in this document are intended to be used with general-use electronic equipment or devices (such as audio visual equipment, office-automation equipment, communication devices, electronic appliances and amusement devices).

The Products specified in this document are not designed to be radiation tolerant.

While ROHM always makes efforts to enhance the quality and reliability of its Products, a Product may fail or malfunction for a variety of reasons.

Please be sure to implement in your equipment using the Products safety measures to guard against the possibility of physical injury, fire or any other damage caused in the event of the failure of any Product, such as derating, redundancy, fire control and fail-safe designs. ROHM shall bear no responsibility whatsoever for your use of any Product outside of the prescribed scope or not in accordance with the instruction manual.

The Products are not designed or manufactured to be used with any equipment, device or system which requires an extremely high level of reliability the failure or malfunction of which may result in a direct threat to human life or create a risk of human injury (such as a medical instrument, transportation equipment, aerospace machinery, nuclear-reactor controller, fuel-controller or other safety device). ROHM shall bear no responsibility in any way for use of any of the Products for the above special purposes. If a Product is intended to be used for any such special purpose, please contact a ROHM sales representative before purchasing.

If you intend to export or ship overseas any Product or technology specified herein that may be controlled under the Foreign Exchange and the Foreign Trade Law, you will be required to obtain a license or permit under the Law.



Thank you for your accessing to ROHM product informations.
More detail product informations and catalogs are available, please contact us.

ROHM Customer Support System

<http://www.rohm.com/contact/>