

DWG. NO. SD_87256-***21

CAD FILE S872562.LDGN

▽

DO NOT SCALE DRAWING

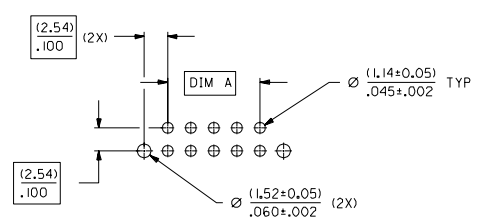
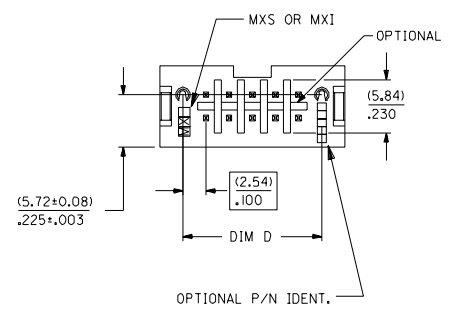
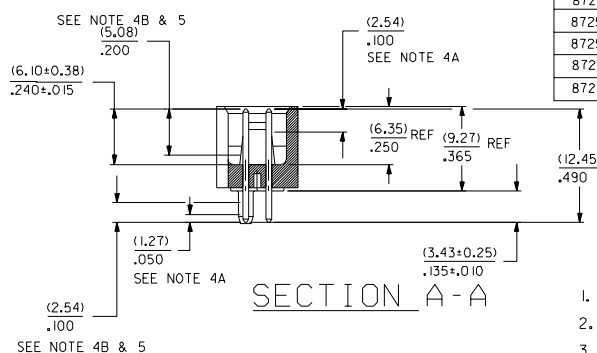
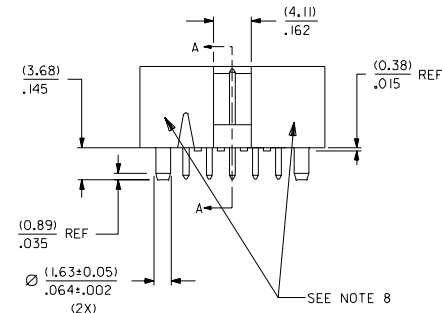
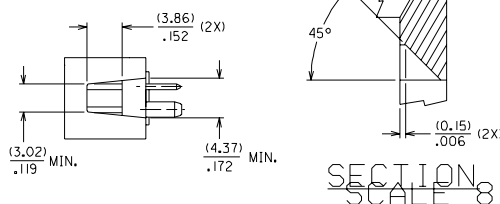
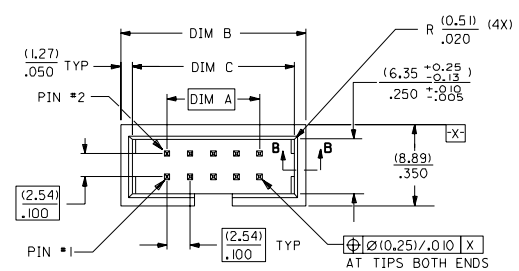

RECOMMENDED PCB PATTERN

PART NUMBERS	CKT SIZE	DIM A	DIM B	DIM C	DIM D
87256-0421	04	(2.54)/.100	(12.70)/.500	(10.16)/.400	(7.62)/.300
87256-0621	06	(5.08)/.200	(15.24)/.600	(12.70)/.500	(10.16)/.400
87256-0821	08	(7.62)/.300	(17.78)/.700	(15.24)/.600	(12.70)/.500
87256-1021	10	(10.16)/.400	(20.32)/.800	(17.78)/.700	(15.24)/.600
87256-1221	12	(12.70)/.500	(22.86)/.900	(20.32)/.800	(17.78)/.700
87256-1421	14	(15.24)/.600	(25.40)/1.000	(22.86)/.900	(20.32)/.800
87256-1621	16	(17.78)/.700	(27.94)/1.100	(25.40)/1.000	(22.86)/.900
87256-1821	18	(20.32)/.800	(30.48)/1.200	(27.94)/1.100	(25.40)/1.000
87256-2021	20	(22.86)/.900	(33.02)/1.300	(30.48)/1.200	(27.94)/1.100
87256-2421	24	(27.94)/1.100	(38.10)/1.500	(35.56)/1.400	(33.02)/1.300
87256-2621	26	(30.48)/1.200	(40.64)/1.600	(38.10)/1.500	(35.56)/1.400
87256-3021	30	(35.56)/1.400	(45.72)/1.800	(43.18)/1.700	(40.64)/1.600
87256-3421	34	(40.64)/1.600	(50.80)/2.000	(48.26)/1.900	(45.72)/1.800
87256-4021	40	(48.26)/1.900	(58.42)/2.300	(55.88)/2.200	(53.34)/2.100
87256-4421	44	(53.34)/2.100	(63.50)/2.500	(60.96)/2.400	(58.42)/2.300
87256-5021	50	(60.96)/2.400	(71.12)/2.800	(68.58)/2.700	(66.04)/2.600
87256-5621	56	(68.58)/2.700	(78.74)/3.100	(76.20)/3.000	(73.66)/2.900
87256-6021	60	(73.66)/2.900	(83.82)/3.300	(81.28)/3.200	(78.74)/3.100
87256-6421	64	(78.74)/3.100	(88.90)/3.500	(86.36)/3.400	(83.82)/3.300
87256-7221	72	(88.90)/3.500	(99.06)/3.900	(96.52)/3.800	(93.98)/3.700

PART NUMBER LEGEND

87256 - * * 2 1

CKT SIZES

NOTES :

- PIN PUSHOUT FORCE (0.9072 KG)/2 LBS MIN.
- PRODUCT SPECIFICATION #70246 APPLIES.
- WAFER TO BE FLAT WITHIN (0.03MM/CM)/.003IN/IN.
- DIMENSIONS FOR PLATING LOCATIONS : A - MEASURE POINT FOR THICKNESS.
B - MINIMUM COVERAGE.
- GOLD END OF PIN UNLESS OVERALL PLATED.
- FINISH : (PER ES-88)
0.13um/5u" MIN GOLD FLASH OVER 1.02um/40u" MIN.PD/NI
IN SELECTED AREA AND 2.5um/100u" MIN.TIN/LEAD IN SELECTED AREA OVER 1.27um/50u" MIN NICKEL OVERALL
- FOR ILLUSTRATION PURPOSE A 10 CKT IS SHOWN.
- OPTIONAL LOCATION FOR WEEK/YEAR STAMP IF REQUIRED BY CUSTOMER

(MM)
INCH

				MATERIAL : WAFER : HIGH TEMP. THERMOPLASTICS PINS : (10.64)/.025 SO CU ALLOY		MOLEX SINGAPORE PTE LTD SHEET 1 OF 1	
				FINISH : SEE DRAWING			
A	RELEASE PER ECN# S50173	S50173	INC	941017	GENERAL TOLERANCES ± 0.20/.008		REV A
LTR	REVISION RECORD	ECN	DR	CHK	DATE	DWG. NO. SD_87256-***21	
REVISE ONLY ON CAD SYSTEM				DRAWN BY KC LING 941017		TITLE : C-GRID, SHROUDED WAFER SLOTTED, WITH IN-LINE POLARIZATION PEGS	
				APPR'D BY		SCALE 2 : 1	