

NOTES:

1. RECOMMENDED SOLDER INSTRUCTION SEE SHEET 2
2. METALSHELLS: COPPER ALLOY; min. 315µin TIN over 40-80µin NICKEL
3. INSULATORS: PBT GF UL 94 V-0, GREEN
4. CONTACTS: COPPER ALLOY
PLATING: 8µin HARD GOLD over min. 50µin NICKEL
SOLDER CUP ACCEPTS CABLE AWG 20
5. HIGH POWER CONTACTS 10A: COPPER ALLOY
PLATING MATING AREA:
8µin HARD GOLD over min. 50µin NICKEL
PLATING TERMINATION SIDE:
8µin HARD GOLD over min. 50µin NICKEL
SOLDER CUP ACCEPTS CABLE AWG 16-20
6. THREADED INSERTS:
COPPER ALLOY; min. 200µin TIN over 80µin NICKEL
7. COLLARS: COPPER ALLOY; min. 200µin TIN over 80µin NICKEL
8. HEXLOCKING SCREWS: STAINLESS STEEL
9. FRAME: ZINC DIE CAST; NICKEL PLATED
10. O-RING: SILICON; BLUE
11. RECOMMENDED PANEL CUT-OUT ON SHEET 2
12. RECOMMENDED TORQUE FOR MOUNTING SCREW
35Ncm (3.1in.LB) / max. 40Ncm (3.5 in.LB)
13. CONNECTOR IS PART MARKED: 6007W2SAM61B30X CONEC ABC

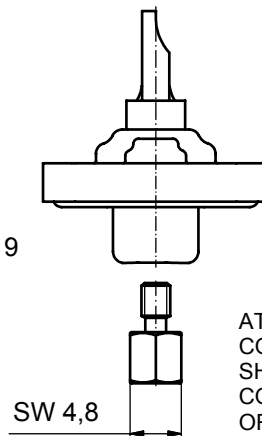
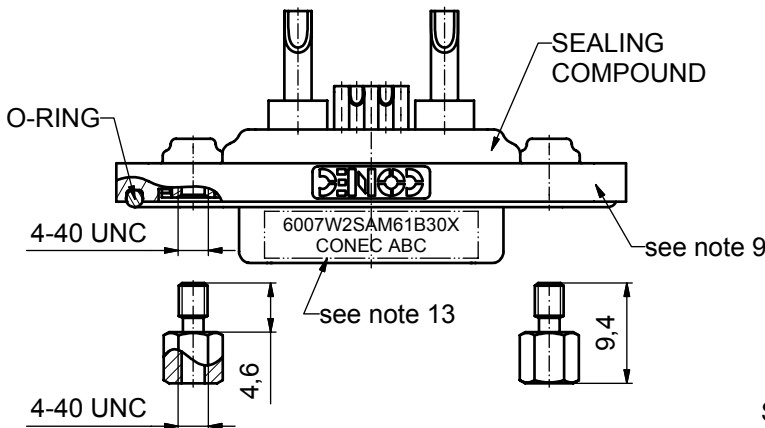
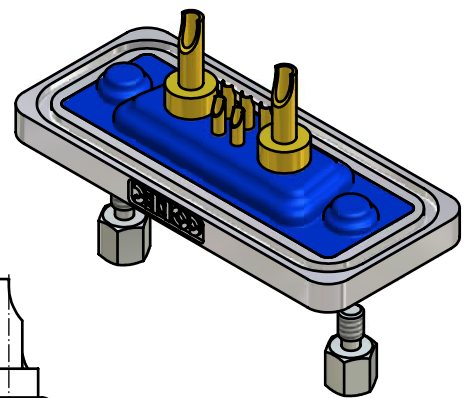
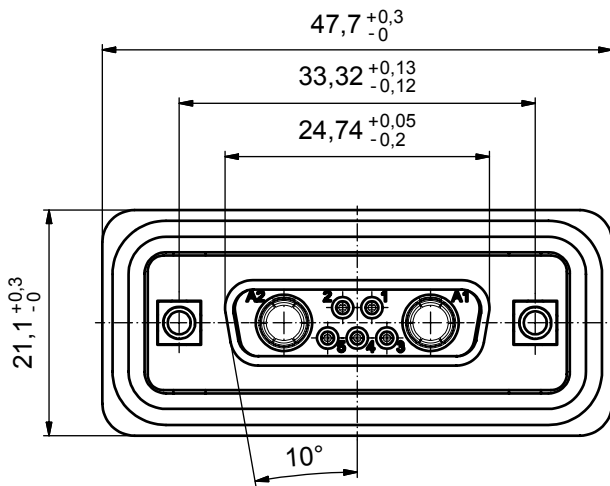
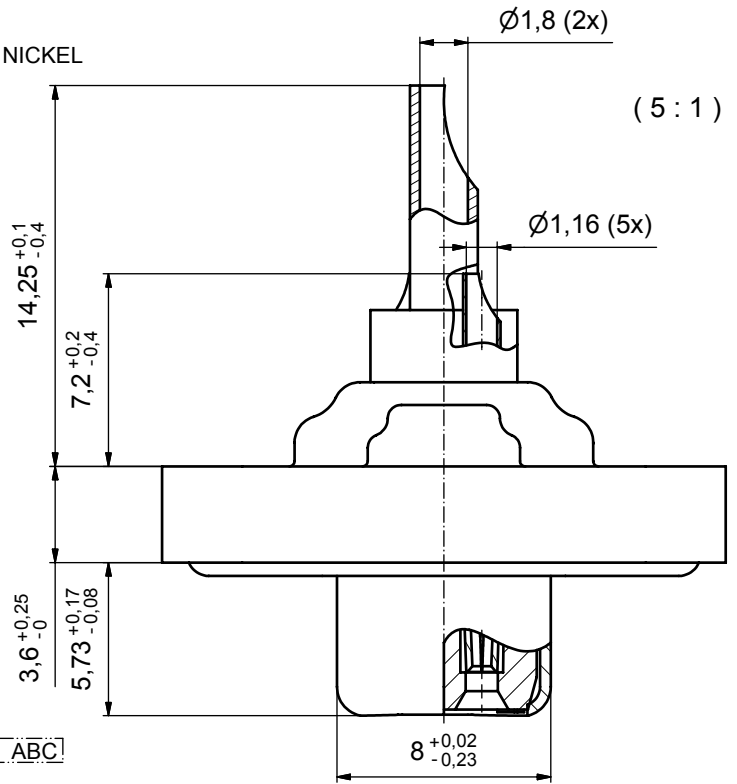

Directive 2002/95/EC
RoHS
Compliant

AT ALL TIMES WATER RESISTANT CONNECTORS NOT IN USE SHOULD BE COVERED WITH A CONEC WATER RESISTANT CAP OR WATER TIGHT HOOD.

APPROVAL # FREIGABE # DEBLOCAGE # AUTORIZACION # APPROVAL	
CUSTOMER APPROVAL DATE:	
NAME:	TITLE:
COMPANY NAME:	
APPROVAL # FREIGABE # DEBLOCAGE # AUTORIZACION # APPROVAL	

THIS DRAWING MAY NOT BE COPIED OR REPRODUCED IN ANY WAY, AND MAY NOT BE PASSED ON TO A THIRD PARTY WITHOUT WRITTEN PERMISSION. OWNERSHIP AND COPYRIGHT OF CONEC GmbH DO NOT ALTER CAD DRAWING BY HAND				tolerance		dim. in mm	scale: 2:1 (5:1)		
							material: see notes		
				drawn	17.06.10		Schmidt		
				appd.	17.06.10		Fischer		
		norm		title:		D-SUB COMBINATION FEMALE 7W2S SOLDER CUP with threaded insert and hexlocking screw			
		d-old		dwg no:				Inventor 10	DIN-A3
				15K1A670				sh: 1	
				CONEC		part no: 6007W2SAM61B30X			
rev.	description	date	name						

Solder Instruction

1. Cable should be prepared for soldering. The cable/wires must be pretinned.
2. Insert cable/wire into solder cup.
3. Signal Contact
 - 3.1. Operate the soldering iron at 350°C, 50 Watt max. and use a pencil tip.
 - 3.2. Put tip to wire in solder cup.
 - 3.3. After 1 second bring in solder.
 - 3.4. Heat for 3 seconds longer. Do not heat contact more than 4 seconds in total.
4. Power Contact
 - 4.1. Operate the soldering iron at 350°C, 100 Watt max. and use a pencil tip.
 - 4.2. Put tip to wire in solder cup.
 - 4.3. After 1 second bring in solder.
 - 4.4. Heat for 5 seconds longer. Do not heat contact more than 6 seconds in total.
5. Remove soldering iron.
6. Wait until solder gets rigid again.
7. Do not solder adjacent contacts consecutively, alternate position within the connector to minimize heat build up.

RECOMMENDED PANEL CUT-OUT

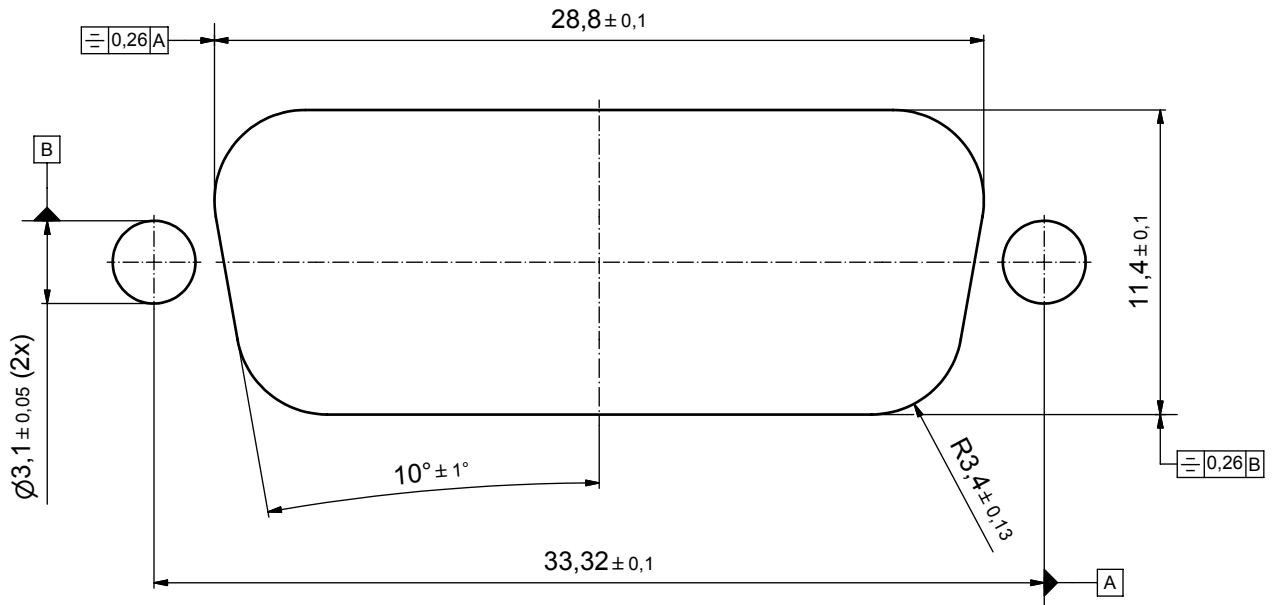

APPROVAL # FREIGABE # DEBLOCAGE # AUTORIZACION # APPROVAL	
CUSTOMER APPROVAL DATE:	
NAME:	TITLE:
COMPANY NAME:	
APPROVAL # FREIGABE # DEBLOCAGE # AUTORIZACION # APPROVAL	

THIS DRAWING MAY NOT BE COPIED OR REPRODUCED IN ANY WAY, AND MAY NOT BE PASSED ON TO A THIRD PARTY WITHOUT WRITTEN PERMISSION. OWNERSHIP AND COPYRIGHT OF CONEC GmbH DO NOT ALTER CAD DRAWING BY HAND				tolerance		 dim. in mm
				date	name	
				drawn	17.06.10 Schmidt	
				appd.	17.06.10 Fischer	
norm						
d-old						
a	Origin					
rev.	description	date	name			



scale: 5:1	
material: see sheet 1	
title: PANEL CUT-OUT	
D-SUB COMBINATION FEMALE 7W2S	
Solder cup; with threaded insert, hexlocking screw	
dwg no: Inventor 10	DIN-A3
15K1A670	
part no: see sheet 1	sh: 2