



NPN SILICON POWER TRANSISTOR

DESCRIPTION

These 2N6315 and 2N6316 devices are an excellent choice for un-tuned amplifier applications. It is also ideal for general purpose power switch and amplifier applications. Microsemi also offers numerous other products to meet higher and lower power voltage regulation applications.



**TO-213AA (TO-66)
Package**

Important: For the latest information, visit our website <http://www.microsemi.com>.

FEATURES

- Hermetically sealed.
- Complimentary pairing with the PNP 2N6317 and 2N6318.
- RoHS compliant versions available.

APPLICATIONS / BENEFITS

- Convenient package.
- Mechanically rugged.
- Commercial, industrial, and military uses.

MAXIMUM RATINGS @ 25 °C unless otherwise stated

Parameters/Test Conditions	Symbol	Value	Unit
Junction and Storage Temperature	T _J and T _{STG}	-65 to +200	°C
Thermal Resistance Junction-to-Lead ⁽¹⁾	R _{θJL}	235	°C
Collector-Base Voltage	V _{CBO}	60 80	V
Emitter-Base Voltage	V _{EBO}	5	V
Collector-Emitter Voltage	V _{CEO}	60 80	V
Continuous Operating Collector Current	I _C	7	A
Continuous Base Current		2	A
Total Power Dissipation ⁽²⁾	P _T	90	W

- NOTES:** 1. At 1/8 inch from case for 10 seconds.
2. Derate linearly at 0.515 W/°C.

MSC – Lawrence

6 Lake Street,
Lawrence, MA 01841
Tel: 1-800-446-1158 or
(978) 620-2600
Fax: (978) 689-0803

MSC – Ireland

Gort Road Business Park,
Ennis, Co. Clare, Ireland
Tel: +353 (0) 65 6840044
Fax: +353 (0) 65 6822298

Website:

www.microsemi.com

MECHANICAL and PACKAGING

- CASE: Hermetic, TO-66 package. Nickel plate with nickel cap.
- TERMINALS: Solder dipped (Sn63/Pb37) over nickel plated alloy 52. RoHS compliant matte-tin plating is also available.
- MARKING: MSC, part number, date code, polarity symbol.
- WEIGHT: Approximately 5.7 grams.
- See [Package Dimensions](#) on last page.

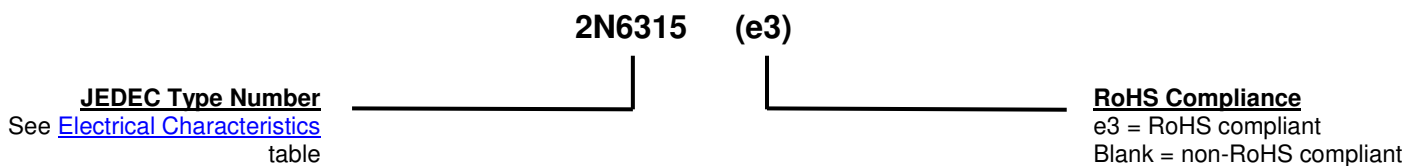
PART NOMENCLATURE

SYMBOLS & DEFINITIONS

Symbol	Definition
I_B	Base current
T_C	Case temperature
V_{CB}	Collector-base voltage
V_{CC}	Collector-supply voltage
V_{EB}	Emitter-base voltage

ELECTRICAL CHARACTERISTICS @ 25 °C unless otherwise stated

Parameters / Test Conditions	Symbol	Min.	Max.	Unit
STATIC CHARACTERISTICS				
Collector Cutoff Current $V_{CE} = 60 V_{BE} = 1.5 V, T_C = 150 ^\circ C$ $V_{CE} = 80 V_{BE} = 1.5 V, T_C = 150 ^\circ C$	2N6315 2N6316	I_{CEX}	2.0	mA
Collector Cutoff Current $V_{CE} = 60 V_{BE} = 1.5 V$ $V_{CE} = 80 V_{BE} = 1.5 V$	2N6315 2N6316	I_{CEX}	0.25	mA
Emitter Cutoff Current $V_{EB} = 5 V$		I_{EBO}	1.0	mA
Collector-Emitter Open Base Sustain Voltage ⁽¹⁾ $I_B = 0, I_C = 100 mA$	2N6315 2N6316	$V_{CEO(sus)}$	60 80	
Collector Cutoff Current, Base Open $I_B = 0, V_{CE} = 30 V$ $I_B = 0, V_{CE} = 40 V$	2N6315 2N6316	I_{CEO}	0.5	mA
DC Forward Current Transfer Ratio ⁽¹⁾ $I_C = 7 A, V_{CE} = 4 V$ $I_C = 2.5 A, V_{CE} = 4 V$ $I_C = 0.5 A, V_{CE} = 4 V$		h_{FE}	4 20 35	100
Collector-Emitter Saturation Voltage ⁽¹⁾ $I_C = 7.0 A, I_B = 1.75 A$ $I_C = 4.0 A, I_B = 0.4 A$		$V_{CE(sat)}$	2.0 1.0	V
Base-Emitter Saturation Voltage ⁽¹⁾ $I_C = 7.0 A, I_B = 1.75 A$		$V_{BE(sat)}$	2.5	V
Base-Emitter Voltage ⁽¹⁾ $I_C = 2.5 A, V_{CE} = 4.0 V$		V_{BE}	1.5	V

NOTE: 1. Pulse Width $\leq 300 \mu s$; duty cycle $\leq 2 \%$.

DYNAMIC CHARACTERISTICS

Parameters / Test Conditions	Symbol	Min.	Max.	Unit
Magnitude of Common Emitter Small-Signal Short-Circuit Forward Current Transfer Ratio $V_{CE} = 10 V, I_C = 0.25 A, f = 1 MHz$	$ h_{fe} $	4		
Common Base Output $V_{CB} = 10 V, I_E = 0 A, f = 1 MHz$	C_{ob}		200	pF
Common Emitter Small-Signal Short-Circuit Forward Current Trans-Ratio $V_{CE} = 4 V, I_C = 0.5 A, f = 1 kHz$	h_{fe}	20		

SWITCHING CHARACTERISTICS

Parameters / Test Conditions	Symbol	Min.	Max.	Unit
Rise time $V_{CC} = 30 V, I_C = 2.5 A, I_{B1} = I_{B2} = 0.25 A$ (see figure 2)	t_r		0.7	μs
Storage time $V_{CC} = 30 V, I_C = 2.5 A, I_{B1} = I_{B2} = 0.25 A$ (see figure 2)	t_s		1.0	μs
Fall time $V_{CC} = 30 V, I_C = 2.5 A, I_{B1} = I_{B2} = 0.25 A$ (see figure 2)	t_f		0.8	μs

GRAPHS

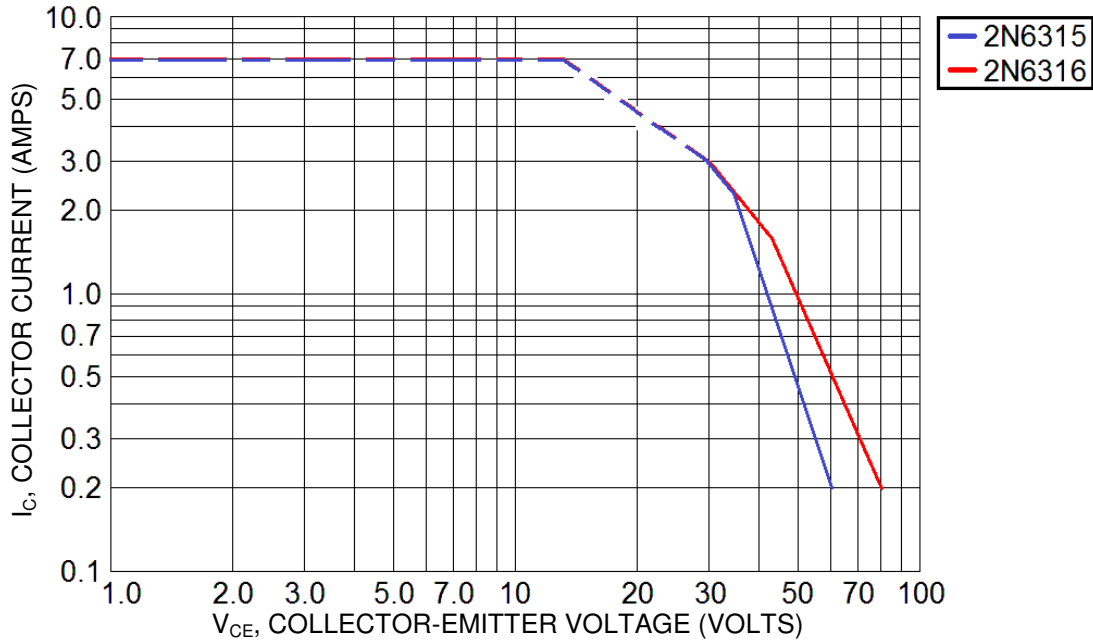

Figure 1
Safe Operating Area ($T_C = 25\text{ }^\circ\text{C}$)

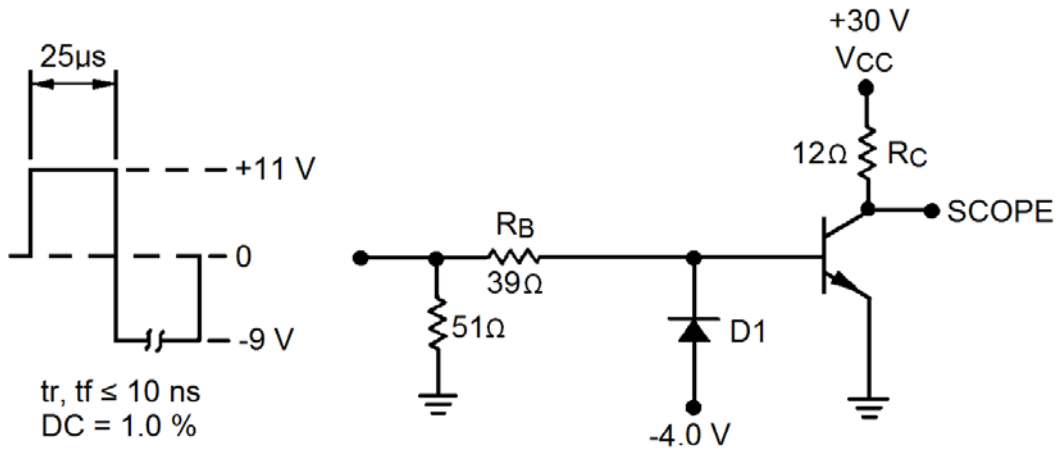
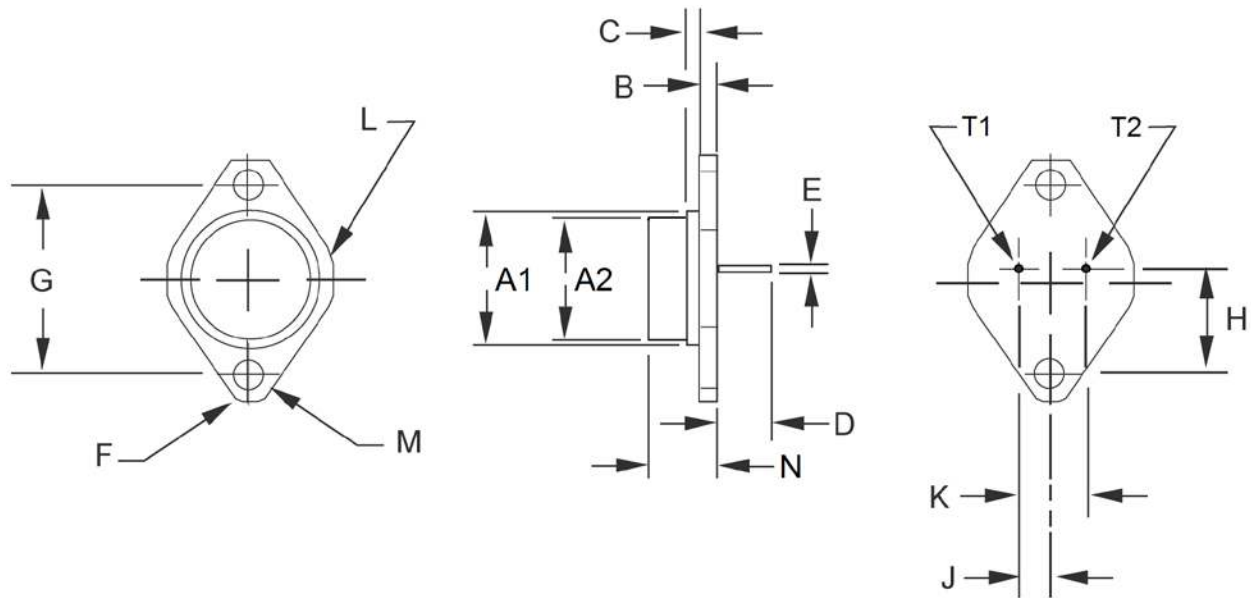

Figure 2
Switching Times Test Circuit

PACKAGE DIMENSIONS

DIM	INCH		MILLIMETERS	
	MIN	MAX	MIN	MAX
A1	.470	.500	11.94	12.70
A2	-	.620	-	15.75
B	.050	.075	1.27	1.91
C	-	.050	-	1.27
D	.360	-	9.14	-
E	.028	.034	0.71	0.86
F	.145 radius		3.68 radius	
G	.958	.962	24.33	24.43
H	.570	.590	14.48	14.99
J	.093	.107	2.36	2.72
K	.190	.210	4.83	5.33
L	.350 radius		8.89 radius	
M	.142	.152	3.61	3.86
N	.250	.340	6.35	8.64
T1	Base			
T2	Emitter			
Case	Collector			