

THIS COPY IS PROVIDED ON A RESTRICTED BASIS AND IS NOT TO BE USED IN ANY WAY DETRIMENTAL TO THE INTERESTS OF PANDUIT CORP.

NOTES:

1. DIMENSIONS IN [] ARE IN MILLIMETERS.

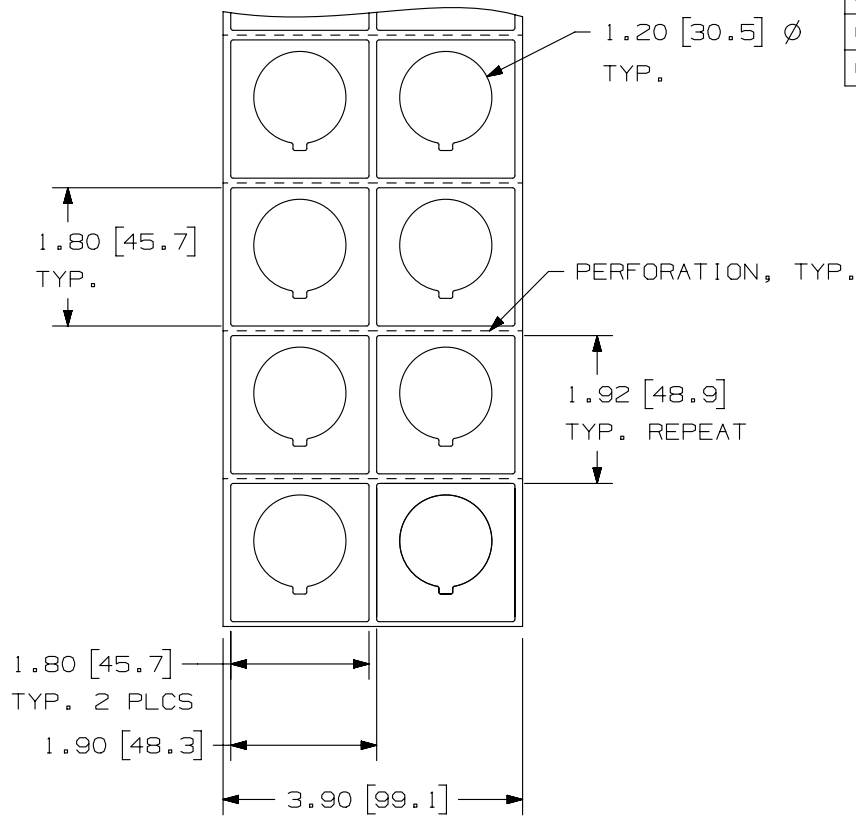

PANDUIT PART NO.	MATERIAL	FACE COLOR	PKG. QTY.	THICKNESS	PRODUCT TYPE
C180X180A0T-30	GMH3	BLACK	500	.030 +/- .010	POLYESTER/ FOAM COMPONENT LABEL
C180X180A8T-30		YELLOW			
C180X180APT-30	GMH3-W	WHITE			
C180X180AST-30	GMH3	GREEN			
C180X180AWT-30		RED			

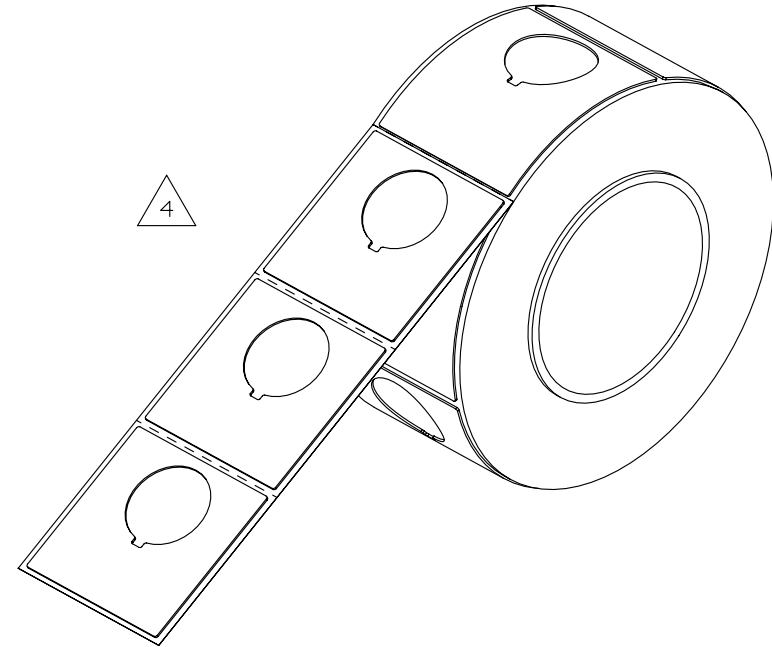

REV	DATE	BY	CHK	APR	DESCRIPTION	ECN
4	1/10/13	RVU	DAPE	SEWH	ADD material column and ISO view. Update part numbers sequence list.	GAECN00513
3	5/3/10	RVU	DAPE		TOL. SHOULD BE .12, .062, NOT .1, .050.	6036
2	1/30/09	RVU	DAPE		REMOVE "REPEAT" FROM THE LABEL SIZE. ADD DIM. PERF. VERTICAL. REMOVE C180X180AMT-22.	5592
1	1/14/09	RVU	DAPE		VOID	
0	9/5/08	RVU	DAPE	PTR	DRAWING RELEASE.	5537

TITLE						
RAISED PANEL PUSH BUTTON LABELS C180X180A*T-30 CUSTOMER DRAWING						
ITEM REVISION NAME				100491BN/05		
DATASET FILE NAME				100491BN-DC-C10727/05E		
UNLESS OTHERWISE SPECIFIED, DIMENSIONAL TOLERANCES ARE: IN [mm]				PANDUIT TM MATERIAL: SEE TABLE		
.x ± .12 [3.05] .xxx ± .025 [.635] .xx ± .062 [1.57] ANGLES ±						
THIRD ANGLE PROJECTION				DRAWING NUMBER: C10727		
DRAWN BY	DATE	CHK	SCALE	SHT 1 OF 1		SIZE
RVU	9/5/08	MSAD	NTS			A

D10100DA/12