

REVISIONS				
SYM	ZONE	ECN, ERN NO.	DATE	APPRD.
A		PROPOSAL	06/02/27	L.CHAN
B		PER ECN E07135	JUN 5/07	L.CHAN
C		UPDATE PER ACTUAL PART.	OCT22/15	L.CHAN

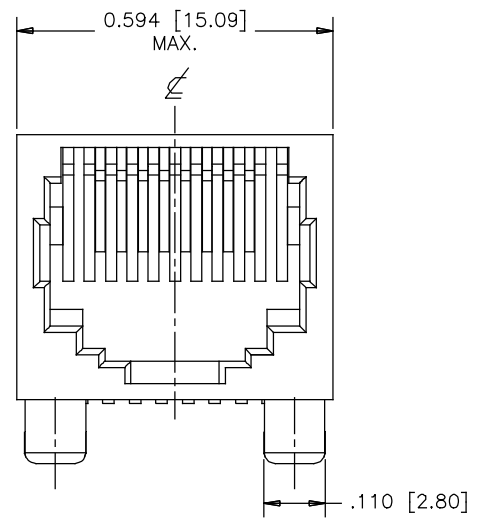

FRONT VIEW

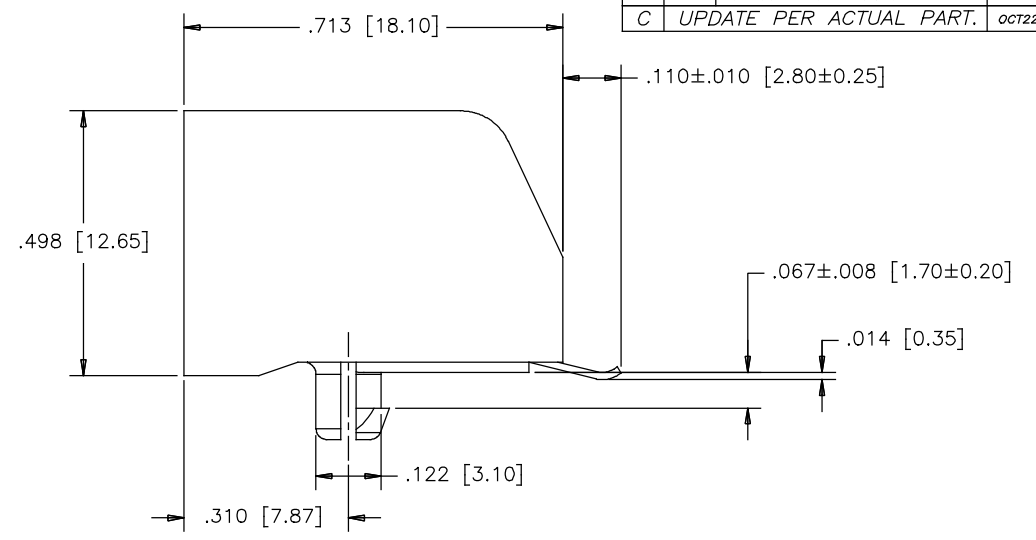

SIDE VIEW

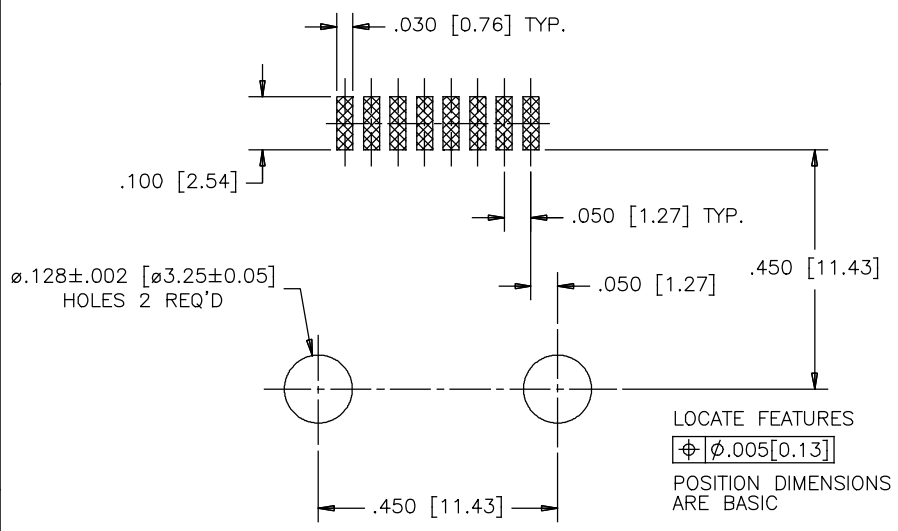

RECOMMENDED P.C.B. LAYOUT
(COMPONENT SIDE OF BOARD)

MATERIALS:

HOUSING: HIGH TEMPERATURE THERMOPLASTIC
FLAMMABILITY RATING UL94V-0
COLOR: BLACK

CONTACTS: PHOSPHOR BRONZE

PLATING: MATING AREA: SELECTIVELY PLATED GOLD—PER
PART NUMBER OPTIONS
50 MICROINCH [1.27 MICRONS] MIN. NICKEL OVERALL
100 MICROINCH [2.54 MICRONS] MIN. MATTE TIN
OR GOLD FLASH OVER TAIL

AMPHENOL PART NUMBER: RJE07-188-0X10

- GOLD PLATING**
- 1 = 06 MICROINCH
 - 2 = 15 MICROINCH
 - 3 = 30 MICROINCH
 - 4 = 50 MICROINCH



DRAWN PAULW	DATE 06/02/27
DESIGNED	
CHECKED CHIGOW	06/02/27
I. E. APPRD. JEFF.S	JUN 5/07
Q. A. APPRD. KENT.Y	JUN 5/07
DWG. APPRD.	
ENG. REL. NO. E07135	
REF.	
DIMENSIONS ARE IN inches (mm)	CODE ID. NO. 03554

Amphenol Canada Corp.			
TITLE RJE07 SURFACE MOUNT MODULAR JACK 8 POSITION, 8 CONTACTS, WITHOUT SHIELD, WITHOUT FLANGE AND WITHOUT KEY - RoHS COMPLIANT			
DWG	DRAWING NO.	REV.	
	P-RJE07-188-0X10	C	
SCALE	WT. -----	SURF. -----	SHEET 1 OF 1

THIS DOCUMENT CONTAINS PROPRIETARY INFORMATION AND SUCH INFORMATION MAY NOT BE DISCLOSED TO OTHERS FOR ANY PURPOSE OR USED FOR MANUFACTURING PURPOSES WITHOUT WRITTEN PERMISSION FROM AMPHENOL CANADA CORP.