

THIS DRAWING IS UNPUBLISHED. RELEASED FOR PUBLICATION
 © COPYRIGHT - By - ALL RIGHTS RESERVED.

LOC		DIST		REVISIONS			
P	LTR	DESCRIPTION		DATE	DWN	APVD	
U		REV PER ECO-12-007856		25APR12	PY	RL	

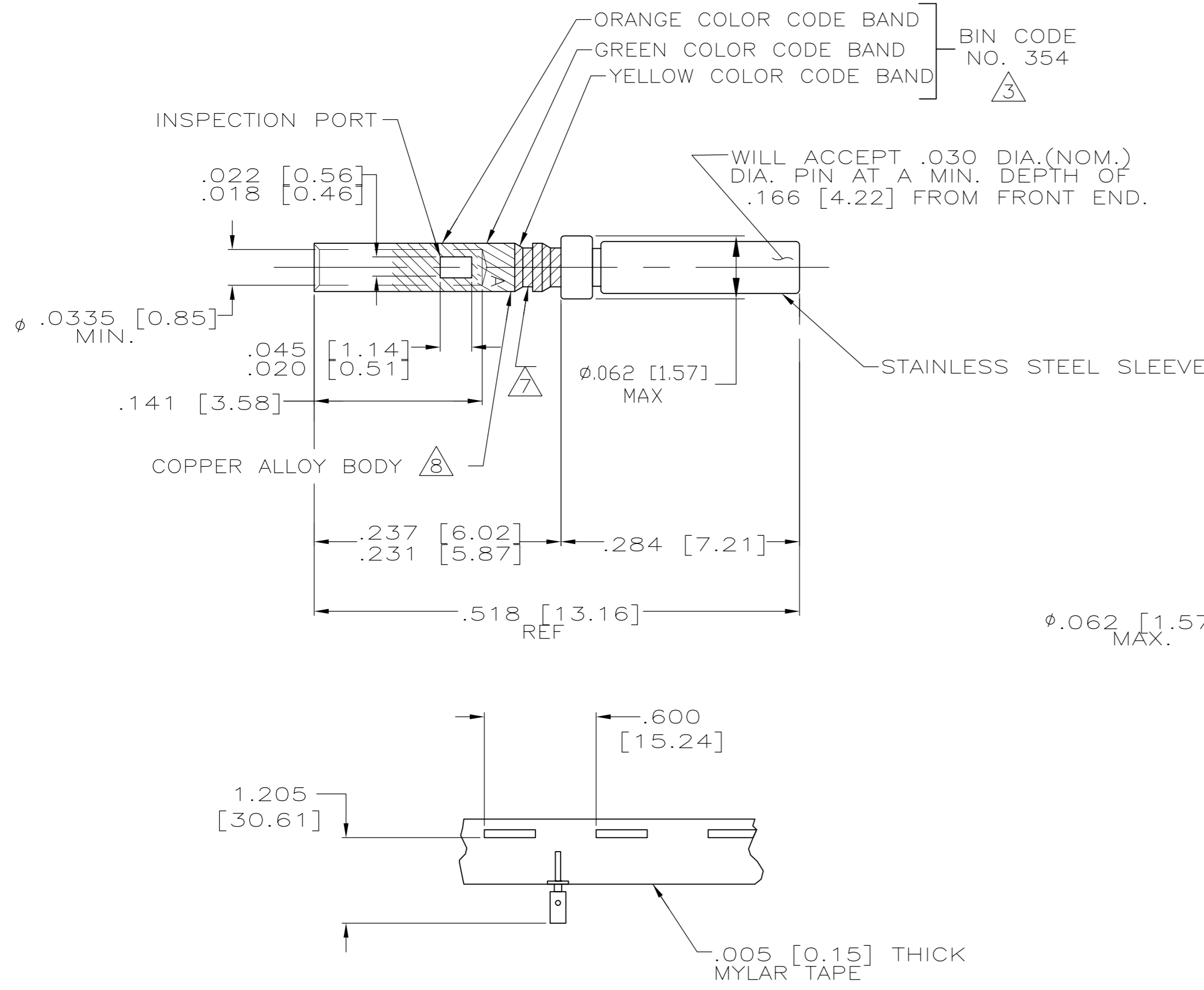

1. WIRE BARREL WILL ACCEPT #22-28 AWG WIRE.
2. CRIMPING TOOL- USE MS3198-1 WITH APPLICABLE POSITIONER.
3. CONTACT CONFORMS TO MIL-C-39029/57, SIZE 22.
4. NET WEIGHT- .102 GRAMS.
5. INSERTION, EXTRACTION TOOL- AMP P/N 91067-1.
6. THIS CONTACT IDENTIFIED AS MS27491-22 SUPERSEDES M24308/12-1.
7. IDENTIFICATION GROOVE IS OPTIONAL.
8. PLATING: GOLD PER ASTM-B-488 OVER NICKEL.
9. MANUFACTURER'S LOGO ("A" OR " - . . . ") LOCALATIONAL OPTIONAL

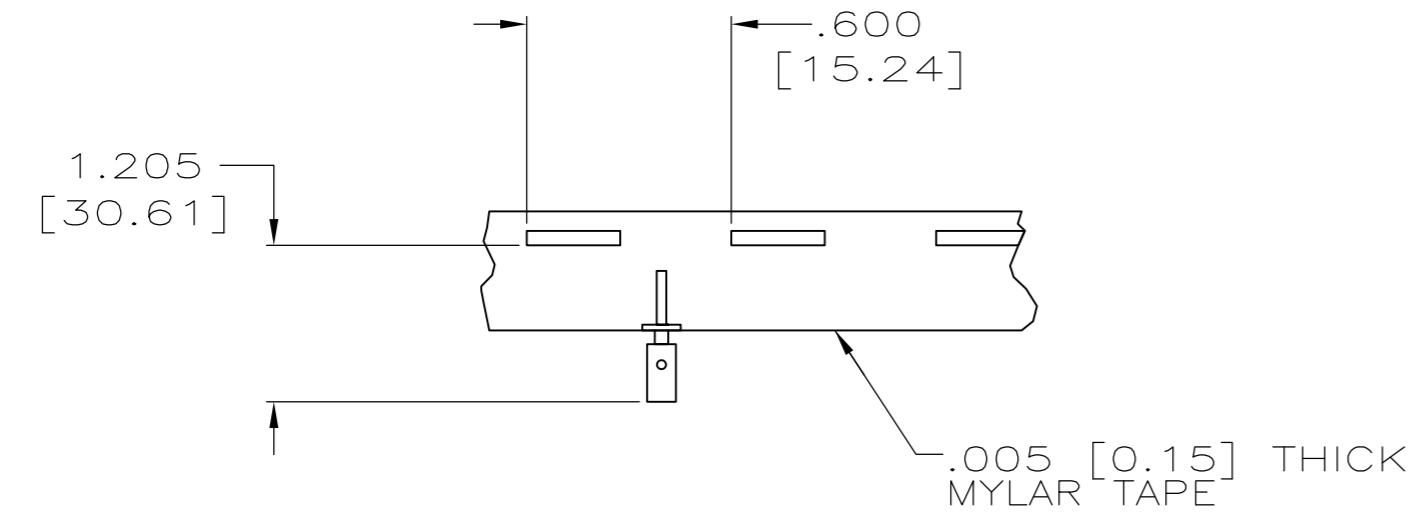
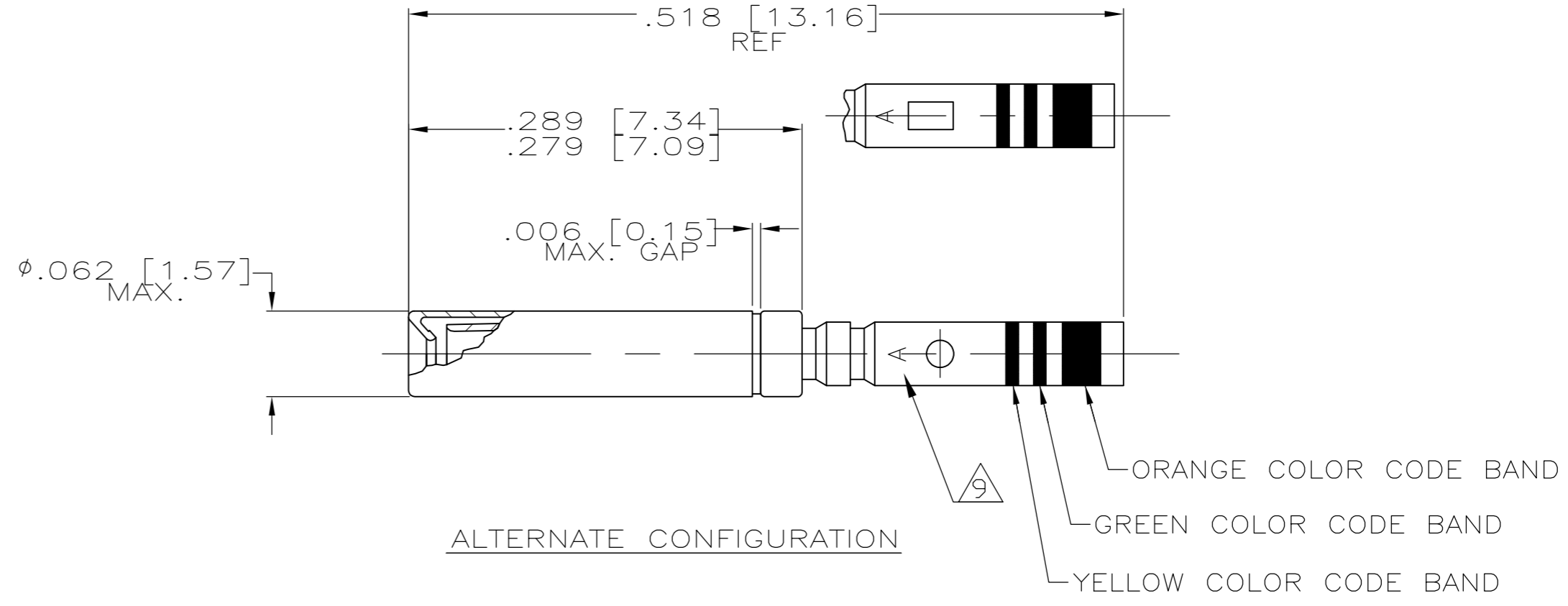

WHEN ORDERING CONTACT ON TAPE, ORDER BY THE TAPE NUMBER PLUS THE PACKAGING CODE AS FOLLOWS:

2. FOR USE WITH AMP TAPETRONIC, PNEUMATIC TOOL-
 A. 1000 PARTS TO A BOX ADD PACKAGING CODE: 1MBOX
3. FOR USE WITH 4/8 INDENT STRIPPER CRIMPER-
 A. 1000 PARTS TO A REEL ADD PACKAGING CODE: 1MREEL
 B. 5000 PARTS TO A REEL ADD PACKAGING CODE: 5MREEL

DESCRIPTION	PLATING	PART NO.
CONTACTS ON TAPE; COLOR CODED	8	204351-6
AS SHOWN; COLOR CODED	8	204351-5
AS SHOWN; NO COLOR CODE	8	204351-4
CONTACTS ON TAPE; COLOR CODED	8	204351-2
AS SHOWN; COLOR CODED	8	204351-1

THIS DRAWING IS A CONTROLLED DOCUMENT.		DWN R. RINEHART 10-5-90	TE TE Connectivity	
DIMENSIONS: INCHES		CHK R. GILLIMAN 10-10-90		
TOLERANCES UNLESS OTHERWISE SPECIFIED:		APVD R. GILLIMAN 10-10-90	NAME CONTACT ASS'Y, SOCKET SIZE 22D, AMPLIMITE	
0 PLC ± -		PRODUCT SPEC	SIZE CAGE CODE DRAWING NO RESTRICTED TO	
1 PLC ± -		APPLICATION SPEC	A2 00779 C=204351	
2 PLC ± -			SCALE 10:1 SHEET 1 OF 1 REV U	
3 PLC ± .005 [0.13]				
4 PLC ± -				
ANGLES ± -				
FINISH		WEIGHT .102 GRAMS		
		CUSTOMER DRAWING		