

THIS DRAWING IS UNPUBLISHED. RELEASED FOR PUBLICATION .19  
 © COPYRIGHT 19 BY AMP INCORPORATED, HARRISBURG, PA. ALL INTERNATIONAL RIGHTS RESERVED. AMP PRODUCTS MAY BE COVERED BY U.S. AND FOREIGN PATENTS AND/OR PATENTS PENDING.

REVISIONS				DATE	APPROVED
P	F	ZONE	LTR	DESCRIPTION	
L			L	REVISED; ECN AA-6527	11-90 LHS NJ

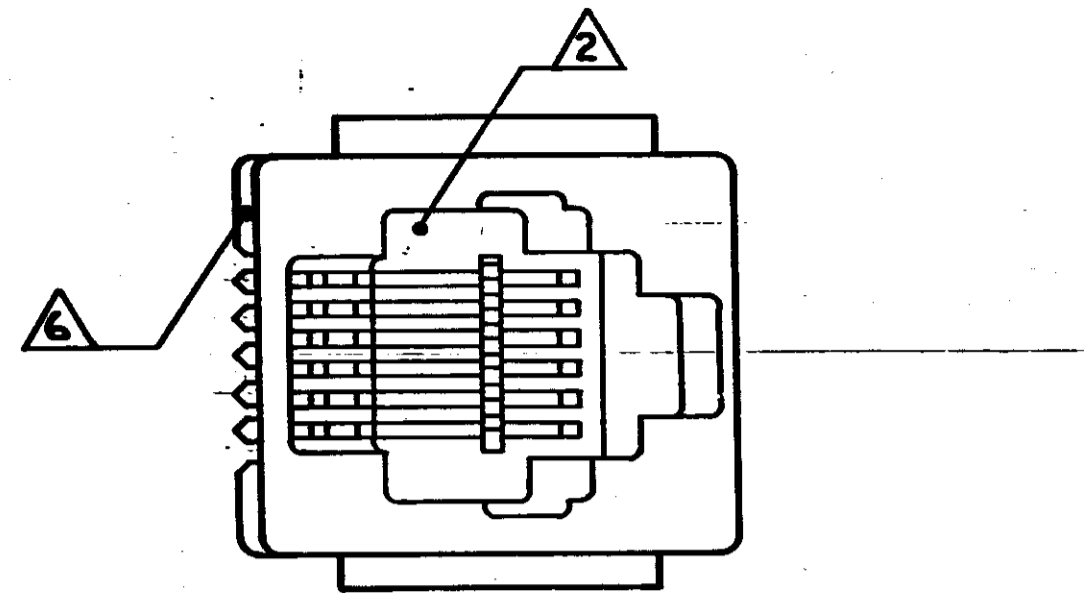

- 1 MATERIAL: HOUSING - PBT POLYESTER, BLACK, TERMINAL - .0138 THICK PHOS-BRONZE PLATED WITH .00005 THICK HARD GOLD IN LOCALIZED GOLD PLATE AREA AND .00008 THICK TIN-LEAD IN SOLDER AREA OVER .00005 THICK NICKEL UNDERPLATE.
- 2 CAVITY CONFORMS TO FCC RULES AND REGULATIONS PART 68 AND REA BULLETIN 345-81, PE-76 SPECIFICATION FOR MODULAR TELEPHONE HARDWARE.
- 3. FOR APPLICATION INFORMATION SEE AMP SPECIFICATION 114-2048.
- 4. FOR PERFORMANCE REQUIREMENTS SEE AMP SPECIFICATION 108-1163.
- 5. ALL DIMENSIONS SHOWN ARE MAXIMUM UNLESS OTHERWISE SPECIFIED.
- 6 VENDOR DESIGNATION SHALL BE THE LETTER 'A' ON THIS SURFACE.
- 7 BULK PACKAGED IN A TRAY.
- 8 PACKAGED 28 PER TUBE.

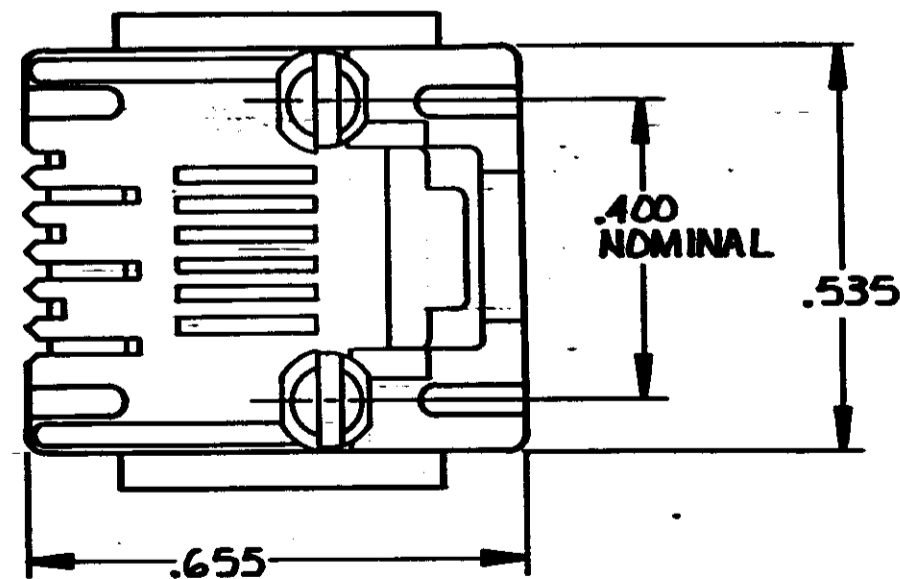
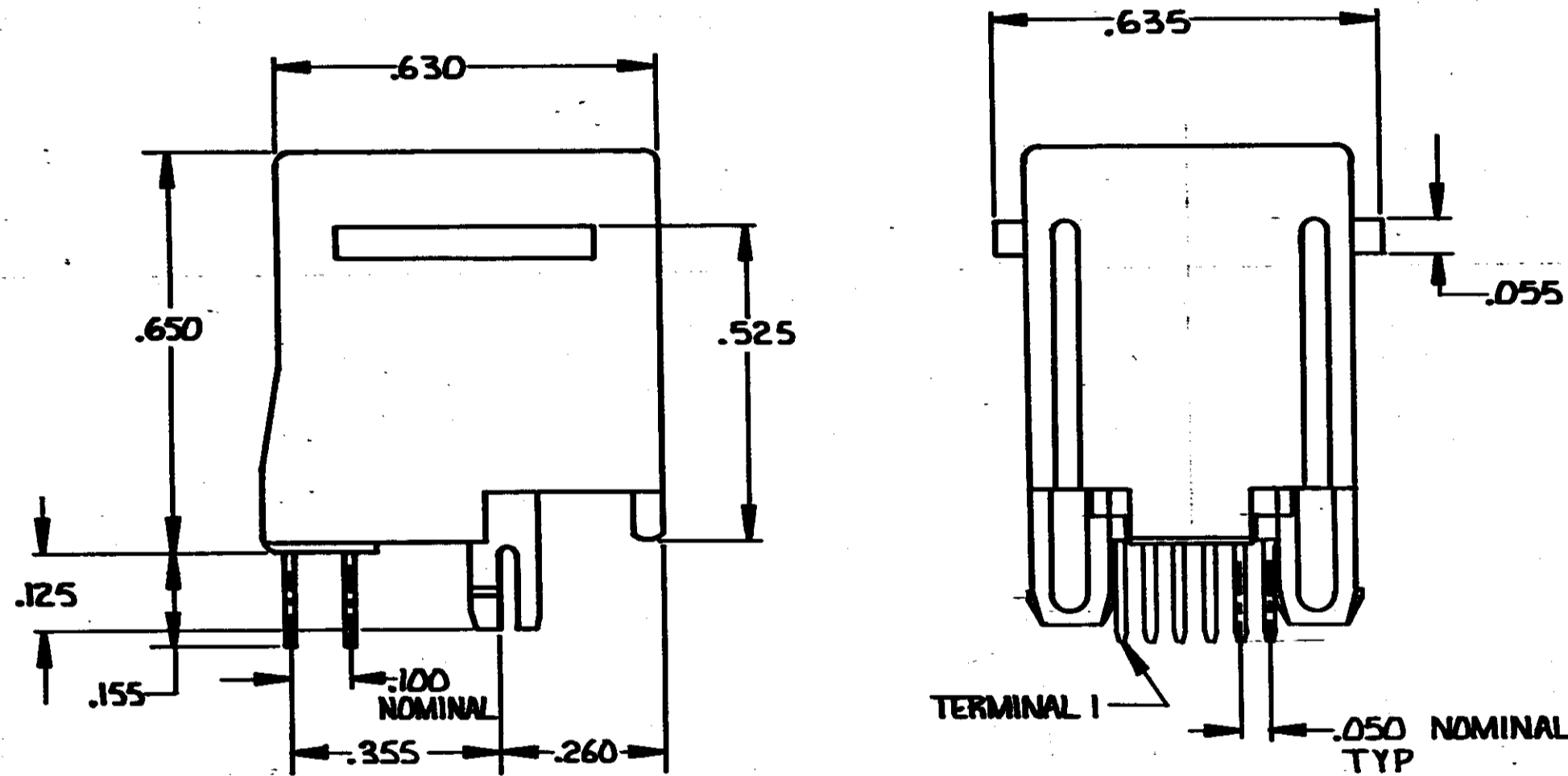

8	6	-4
7	6	-3
	4	520258 - 2
PACKAGED	CONTACTS	PART NO

UNLESS OTHERWISE SPECIFIED DIMENSIONS ARE IN INCHES. TOLERANCES ON: DECIMALS ± ANGLES ±	CONTRACT NO	AMP   AMP INCORPORATED Harrisburg, Pa. 17105	
	DR <i>STWARTEN 12/2/87</i>	NAME PRINTED CIRCUIT BOARD MODULAR JACK ASSEMBLY, TOP ENTRY, 6 POSITION, FLANGELESS WITH PANEL STOPS	
MATERIAL	CHK <i>A.C. Clark 12-4-87</i>	SIZE C	FSCM NO 00779
FINISH	APPD <i>[Signature]</i>	DRAWING NO 520258	
	APPD <i>[Signature]</i>	SCALE 4:1	SHEET 1 of 1
	DSGN APPD		
	OTHER APPD		

520258