

**ebm-papst Muldingen GmbH & Co. KG**

Bachmühle 2 · D-74673 Muldingen

Phone +49 7938 81-0

Fax +49 7938 81-110

info1@de.ebmpapst.com

www.ebmpapst.com

Limited partnership · Headquarters Muldingen

Amtsgericht (court of registration) Stuttgart · HRA 590344

General partner Elektrobau Muldingen GmbH · Headquarters Muldingen

Amtsgericht (court of registration) Stuttgart · HRB 590142

**Nominal data**

<b>Type</b>	<b>A2E300-AP02-01</b>		
<b>Motor</b>	<b>M2E074-DF</b>		
Phase		1~	1~
Nominal voltage	VAC	230	230
Frequency	Hz	50	60
Method of obtaining data		fa	fa
Valid for approval/standard		CE	CE
Speed (rpm)	min <sup>-1</sup>	2700	3000
Power consumption	W	230	350
Current draw	A	1.10	1.55
Capacitor	µF	8	8
Capacitor voltage	VDB	400	400
Max. back pressure	Pa	160	50
Max. back pressure	in. wg	0.64	0.2
Min. ambient temperature	°C	-25	-25
Max. ambient temperature	°C	70	50
Starting current	A	2.2	2.1

ml = Max. load · me = Max. efficiency · fa = Free air · cs = Customer specification · ce = Customer equipment  
Subject to change

**Data according to Commission Regulation (EU) 327/2011 (EN 17166)**

		Actual	Req. 2015			
01 Overall efficiency $\eta_{es}$	%	31.6	30.2	09 Power consumption $P_e$	kW	0.28
02 Measurement category		A		09 Air flow $q_v$	m <sup>3</sup> /h	2245
03 Efficiency category		Static		09 Pressure increase $p_{fs}$	Pa	143
04 Efficiency grade N		41.4	40	10 Speed (rpm) n	min <sup>-1</sup>	2605
05 Variable speed drive		No		11 Specific ratio*		1.00

Data obtained at optimum efficiency level.

The ErP data is determined using a motor-impeller combination in a standardized measurement setup.

\* Specific ratio =  $1 + p_{fs} / 100\,000\text{ Pa}$ 

LU-77994



### Technical description

<b>Weight</b>	3.13 kg
<b>Size</b>	300 mm
<b>Motor size</b>	74
<b>Rotor surface</b>	Painted black
<b>Blade material</b>	Sheet steel, painted black
<b>Number of blades</b>	5
<b>Airflow direction</b>	V
<b>Direction of rotation</b>	Counterclockwise, viewed toward rotor
<b>Degree of protection</b>	IP44; installation- and position-dependent as per EN 60034-5
<b>Insulation class</b>	"F"
<b>Moisture (F) / Environmental (H) protection class</b>	H1
<b>Max. permitted ambient temp. for motor (transport/storage)</b>	+ 80 °C
<b>Min. permitted ambient temp. for motor (transport/storage)</b>	- 40 °C
<b>Installation position</b>	Shaft horizontal or rotor on bottom; rotor on top on request
<b>Condensation drainage holes</b>	On rotor side
<b>Mode</b>	S1
<b>Motor bearing</b>	Ball bearing
<b>Touch current according to IEC 60990 (measuring circuit Fig. 4, TN system)</b>	< 0.75 mA
<b>Motor protection</b>	Thermal overload protector (TOP) internally connected
<b>With cable</b>	Variable
<b>Protection class</b>	I (with customer connection of protective earth)
<b>Conformity with standards</b>	EN 60335-1; CE
<b>Approval</b>	CCC; EAC

## AC axial fan

sickle-shaped blades (S series)

## Product drawing

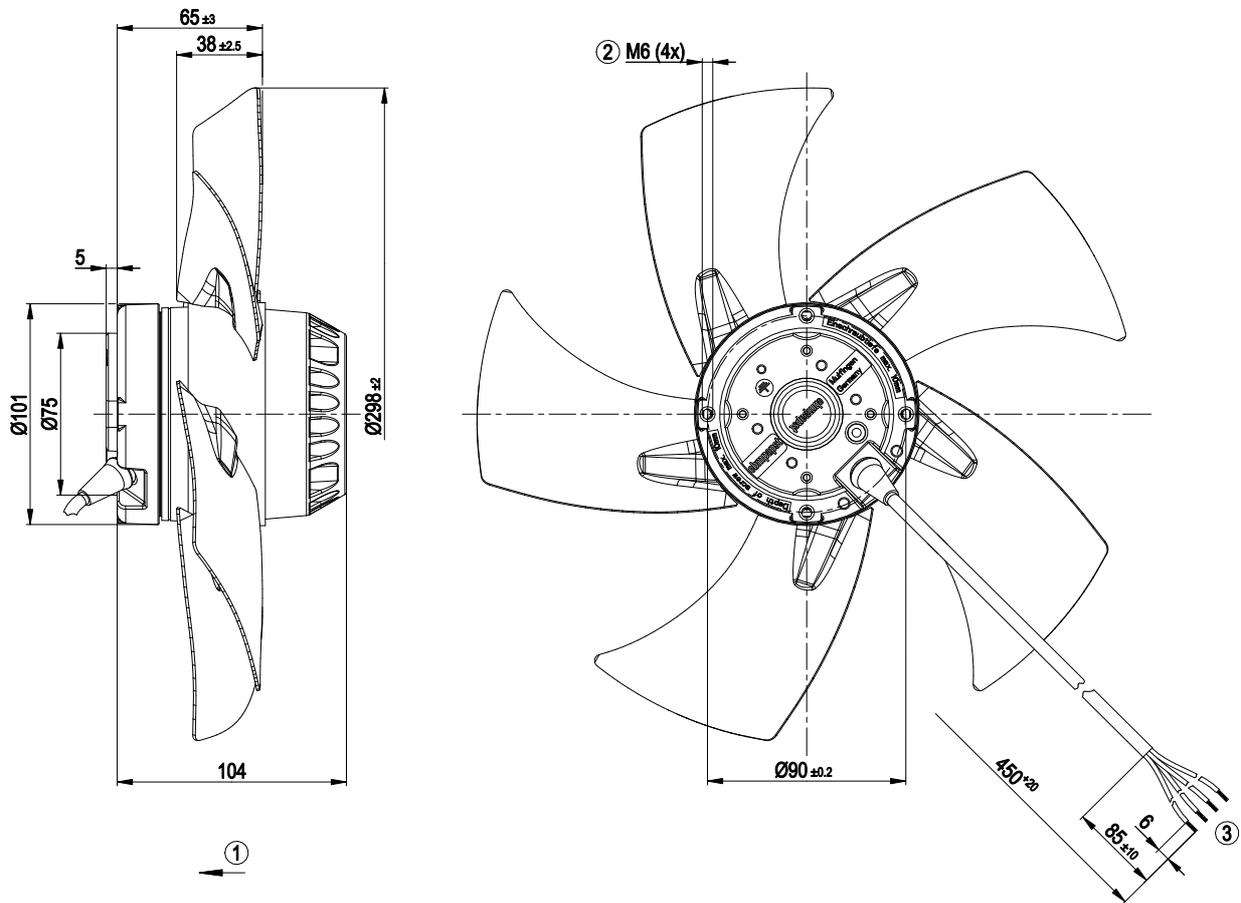

1	Direction of air flow "V"
2	Max. clearance for screw 10 mm
3	Cable silicone 4G 0.5 mm <sup>2</sup>
	4x splice

# AC axial fan

sickle-shaped blades (S series)

## Connection diagram

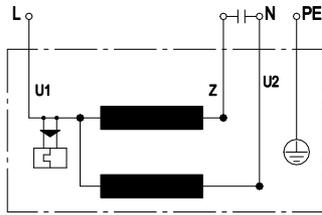

U1	blue	Z	brown	U2	black
PE	green/yellow				

## Curves: Air performance 50 Hz

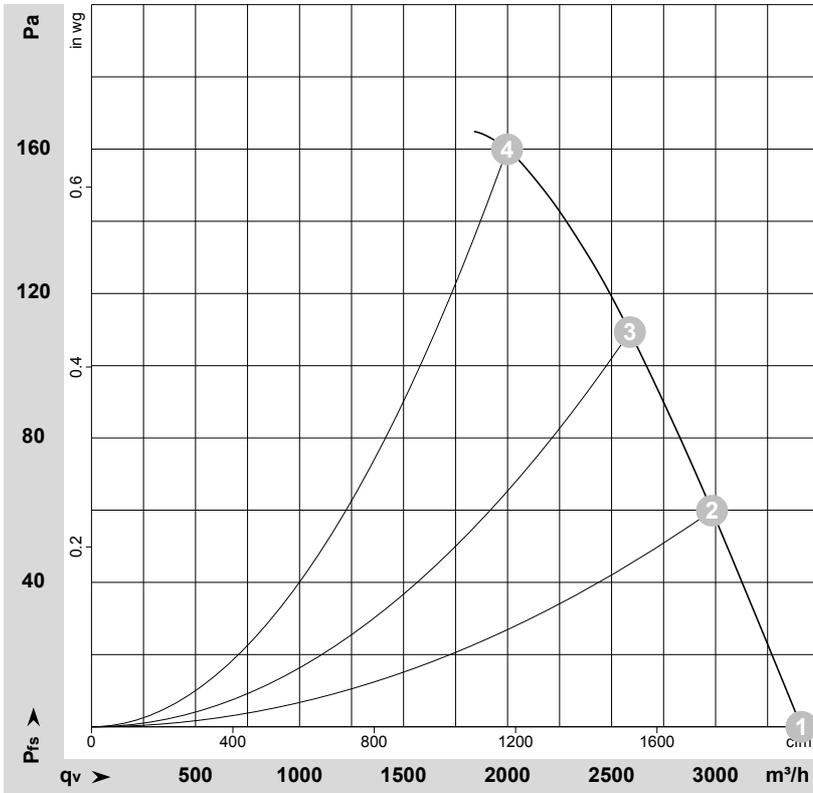

$\rho = 1.15 \text{ kg/m}^3 \pm 2 \%$

Measurement: LU-29177-1

Air performance measured according to ISO 5801 installation category A. For detailed information on the measurement setup, contact ebm-papst. Intake sound level: Sound power level according to ISO 13347 / sound pressure level measured at 1 m distance from fan axis. The values given are valid under the specified measuring conditions and may vary due to conditions of installation. For deviations from the standard configuration, the parameters have to be checked on the installed unit.

## Measured values

	U	f	n	P <sub>e</sub>	I	LpA <sub>in</sub>	LwA <sub>in</sub>	q <sub>v</sub>	p <sub>fs</sub>	q <sub>v</sub>	p <sub>fs</sub>
	V	Hz	min <sup>-1</sup>	W	A	dB(A)	dB(A)	m <sup>3</sup> /h	Pa	cfm	in. wg
1	230	50	2700	230	1.10	73	80	3415	0	2010	0.00
2	230	50	2675	256	1.12	73	80	2985	60	1755	0.24
3	230	50	2615	275	1.20	73	80	2590	110	1525	0.44
4	230	50	2540	300	1.31	74	82	2000	160	1175	0.64

U = Voltage · f = Frequency · n = Speed (rpm) · P<sub>e</sub> = Power consumption · I = Current draw · LpA<sub>in</sub> = Sound pressure level intake side · LwA<sub>in</sub> = Sound power level intake side  
 q<sub>v</sub> = Air flow · p<sub>fs</sub> = Pressure increase



## Curves: Air performance 60 Hz

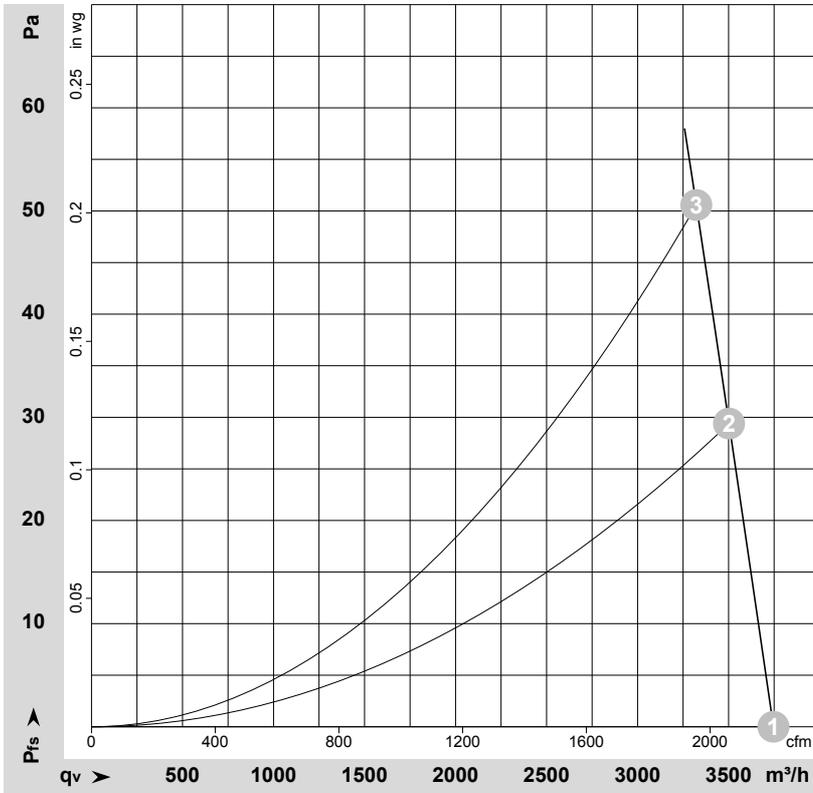

$\rho = 1.15 \text{ kg/m}^3 \pm 2 \%$

Measurement: LU-29105-1

Air performance measured according to ISO 5801 installation category A. For detailed information on the measurement setup, contact ebm-papst. Intake sound level: Sound power level according to ISO 13347 / sound pressure level measured at 1 m distance from fan axis. The values given are valid under the specified measuring conditions and may vary due to conditions of installation. For deviations from the standard configuration, the parameters have to be checked on the installed unit.

## Measured values

	U	f	n	P <sub>e</sub>	I	LpA <sub>in</sub>	LwA <sub>in</sub>	q <sub>v</sub>	p <sub>fs</sub>	q <sub>v</sub>	p <sub>fs</sub>
	V	Hz	min <sup>-1</sup>	W	A	dB(A)	dB(A)	m <sup>3</sup> /h	Pa	cfm	in. wg
1	230	60	3000	350	1.55	77	84	3745	0	2205	0.00
2	230	60	2930	357	1.58	76	83	3500	30	2060	0.12
3	230	60	2875	362	1.60	75	83	3325	50	1955	0.20

U = Voltage · f = Frequency · n = Speed (rpm) · P<sub>e</sub> = Power consumption · I = Current draw · LpA<sub>in</sub> = Sound pressure level intake side · LwA<sub>in</sub> = Sound power level intake side  
 q<sub>v</sub> = Air flow · p<sub>fs</sub> = Pressure increase

