

Fast-Settling FET OPERATIONAL AMPLIFIERS

FEATURES

- **SETTLING TIME (0.01%), 600nsec, max**
- **TRUE DIFFERENTIAL INPUT**
- **SLEW RATE, 100V/ μ sec, min**
- **FULL POWER, 1.5MHz, min**
- **INPUT IMPEDANCE, $10^{11}\Omega$**
- **INTERNALLY COMPENSATED**
- **STABLE OPERATION, 1000pF, typ**

DESCRIPTION

The 3550 is specifically designed for fast transient applications such as D/A and A/D conversion, sample/hold, multiplexer buffering and pulse amplification where the primary amplifier requirements are fast settling, good accuracy, and high input impedance.

Because the 3550 is internally compensated, elaborate compensation schemes requiring external components are not necessary. The smooth 6dB/octave rolloff of open-loop gain and the low output impedance provides the excellent step response and smooth settling without sacrificing frequency stability (no oscillations even with 1000pF of capacitive load)! A 10 to 1 improvement in settling time with large capacitive loads can be obtained with the addition of a single capacitor.

Unlike many wideband and fast settling amplifiers the 3550 has a true differential input. This means it can provide its excellent transient performance in the inverting, non-inverting, current to voltage, and difference configurations.

The 3550J and S have identical specifications except for temperature range: The 3550J is specified for 0°C to +70°C and the 3550S is specified for -55°C to +125°C. The 3550K has improved dynamic specifications and is specified over the 0°C to +70°C temperature range.

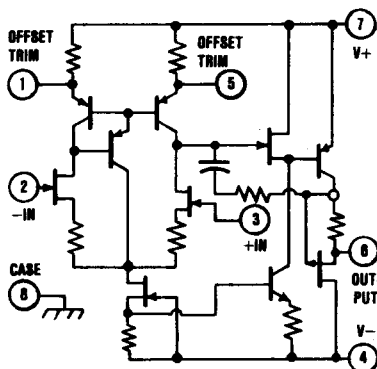

SPECIFICATIONS

ELECTRICAL

Specifications typical at +25°C and ±15VDC Power Supply unless otherwise noted.

MODELS	3550J	3550K	3550S
OPEN LOOP GAIN, DC No load 1kΩ, load min		100dB 88dB	
RATED OUTPUT Voltage, min Current, min Open-loop Output Resistance		±10V ±10mA 100Ω at 1MHz	
DYNAMIC RESPONSE Bandwidth (0dB, small signal) Full Power Response, min Slew Rate, min Settling Time (0.01%), max	10MHz 1.0MHz 65V/μsec 1μsec	20MHz 1.5MHz 100V/μsec 0.6μsec	10MHz 1.0MHz 65V/μsec 1μsec
INPUT OFFSET VOLTAGE Initial Offset, +25°C, max vs Temperature vs Supply Voltage vs Time		±1mV ±50μV/°C ±500μV/V ±100μV/mo	
INPUT BIAS CURRENT Initial Bias, +25°C, max vs Temperature vs Supply Voltage		-100pA (after full warm-up) doubles every 10°C ±1pA/V	
INPUT DIFFERENCE CURRENT Initial Difference, +25°C		±40pA	
INPUT IMPEDANCE Differential Common Mode		10 ¹⁰ Ω 3pF 10 ¹⁰ Ω 3pF	
INPUT NOISE Voltage, 0.01Hz - 10Hz, p-p 10Hz - 10kHz, rms Current, 0.01Hz - 10Hz, p-p 10Hz - 10kHz, rms		20μV 4μV 0.2pA 1.5pA	
INPUT VOLTAGE RANGE Common-Mode Voltage Common-Mode Rejection Safe Input Voltage, max		±(V _{cc} - 5)V 70dB at +5V, -10V ±Supply	
POWER SUPPLY Rated Voltage Voltage Range, derated Current, quiescent ⁽¹⁾		±15VDC ±5VDC to ±20VDC 11mA	
TEMPERATURE RANGE Specification Operating Storage		0°C to +70°C -55°C to +125°C	-55°C to +125°C -55°C to +125°C

NOTES:

- The use of a finned heat sink is recommended.

MECHANICAL

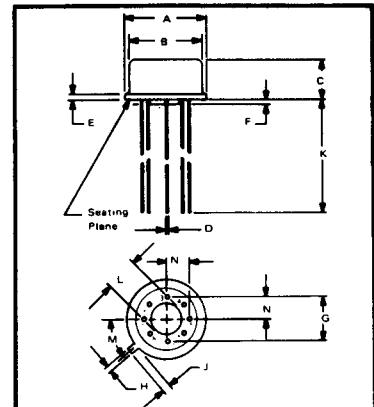

NOTE
Leads in true position within .010" (.25mm) R @ MMC at seating plane.
Pin numbers shown for reference only.
Numbers may not be marked on package.

BOTTOM VIEW

Dimensions in inches are in parentheses.

Pin material and plating composition conform to method 2003 (solderability) of Mil-Std-883 (except paragraph 3.2)

DIM	INCHES		MILLIMETERS	
	MIN	MAX	MIN	MAX
A	.335	.370	8.51	9.40
B	.305	.335	7.75	8.51
C	.165	.185	4.19	4.70
D	.016	.021	0.41	0.53
E	.010	.040	0.25	1.02
F	.010	.040	0.25	1.02
G	.200 BASIC		5.08 BASIC	
H	.028	.034	0.71	0.86
J	.029	.045	0.74	1.14
K	.500		12.7	
L	.110	.160	2.79	4.06
M	.45° BASIC		.45° BASIC	
N	.095	.105	2.41	2.67

CONNECTION DIAGRAM

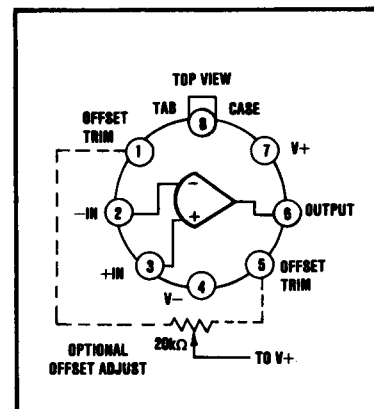

TYPICAL PERFORMANCE CURVES

$T_A = +25^\circ\text{C} \pm V_{CC} = 15\text{VDC}$ unless otherwise indicated.

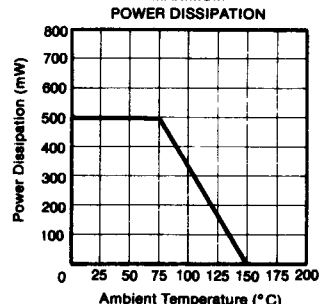
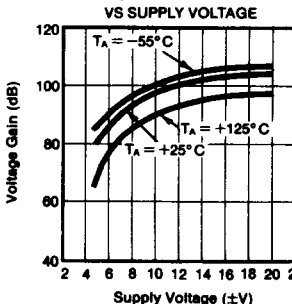
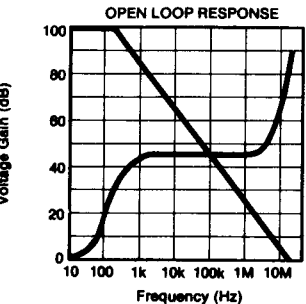
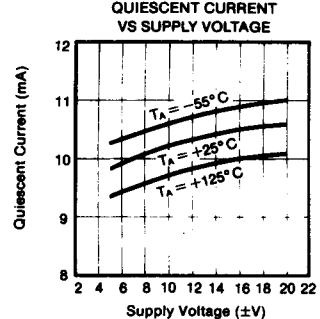
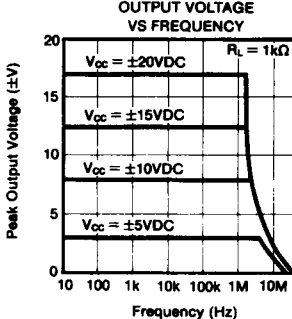
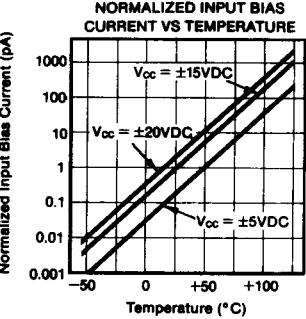
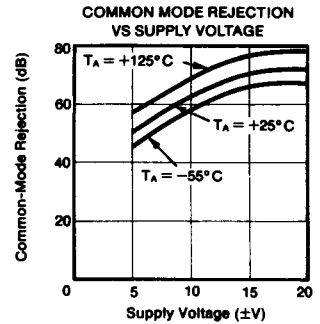
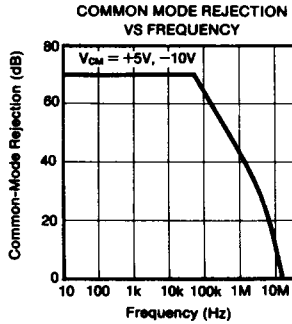
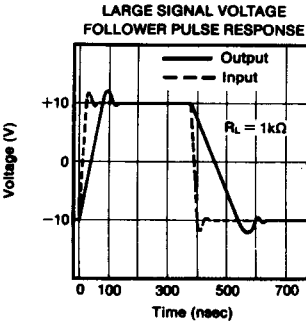
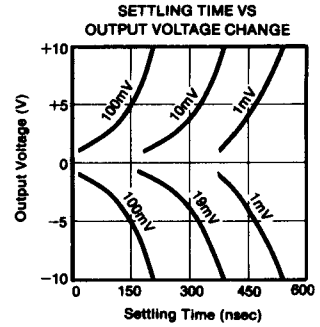
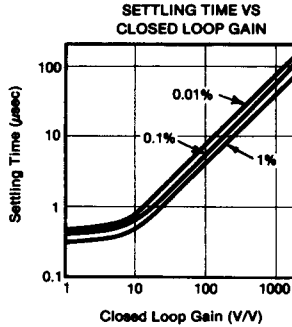
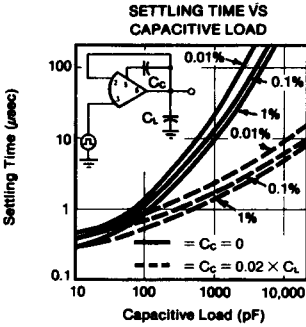

APPLICATIONS

SETTLING TIME

Settling time of an amplifier is defined (see Figure 1) as the total time required, after an input step signal, for the output to "settle" within a specified error band around the final value. This error band is expressed as a percentage of the magnitude of the step transition. A recommended test circuit for settling time is shown in Figure 2. The output error signal appears, attenuated by a factor of two, at point A and may be observed at this point with the aid of an oscilloscope. The diodes act as limiters to prevent overloading the oscilloscope during the fast leading edge of the input signal. All resistors should be $2k\Omega$ or less to eliminate degradation of performance due to stray capacitance. A typical measurement desired is the settling time to 0.01% for a 10-volt step input. This is the time required for the signal at point A to decrease to 0.5mV or less and remain below this level.

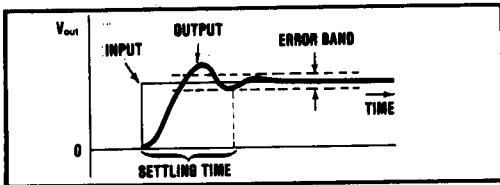

FIGURE 1. Concept of Settling Time.

Settling time for noninverting circuits can also be measured but requires the use of ultra-fast differential amplifier test fixtures. For the 3550 settling time is equal for inverting or noninverting circuits of equal gain.

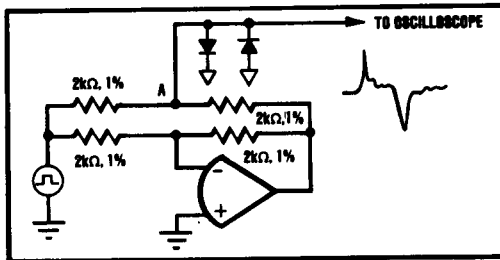

FIGURE 2. Settling Time Test Circuit.

Because settling time is affected by bandwidth which in turn is dependent upon closed-loop gain, the settling time of any operational amplifier will be a function of closed loop gain. Settling Time versus Gain curves illustrate this effect for the 3550 at several levels of settling accuracy.

The 3550 is remarkably tolerant of load capacitance because of its stable, 6dB/octave gain rolloff and low output impedance. Settling Time versus Load Capacitance curves show this characteristic for the unity-gain configuration. For larger values of load capacitance the compensation technique of Figure 3 may be used to optimize the response. The slight negative feedback provided by C_c tends to reduce any ringing at the top of

the output voltage waveform without significantly affecting the slew rate. See the Settling Time versus Load Capacitance curves for typical improvements in settling time.

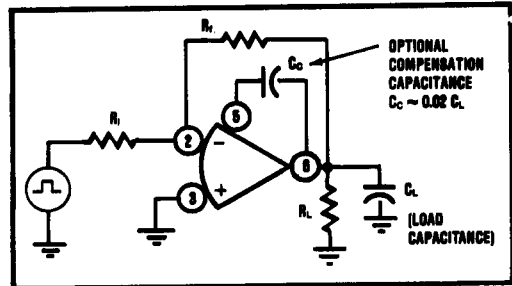

FIGURE 3. Compensation for Load Capacitance.

WIRING RECOMMENDATIONS

In order to fully realize the high frequency performance capabilities of the 3550, proper attention must be given to layout, component selection and grounding. All leads associated with the input and feedback elements should be as short as possible and all connections should be made as close to the amplifier terminals as possible. Input and feedback resistors should be made as small as possible consistent with other circuit constraints. Capacitance from the output to noninverting input can cause high frequency oscillations, particularly in high gain circuits operating from large source impedance. Careful layout of wiring or PC board patterns is the only satisfactory way of preventing such problems.

In order to prevent high frequency oscillations due to lead inductance the power supply leads should be bypassed. This should be done by connecting a $10\mu\text{F}$ tantalum capacitor in parallel with a $0.001\mu\text{F}$ ceramic capacitor from pins 7 and 4 to the power supply common.

INPUT AND OUTPUT VOLTAGE RANGE

Although the 3550 is specified for best operation on power supply voltage of $\pm 15\text{VDC}$, it will operate with minor performance changes over a power supply voltage range of $\pm 5\text{VDC}$ to $\pm 20\text{VDC}$. Many of the curves show performance of the 3550 when operated from supplies other than $\pm 15\text{VDC}$.