

REVISIONS					
REV	ECO	DESCRIPTION	DATE	BY	APPR
A1	--	RELEASE NEW DRAWING	28MAR22	VITO	TOMMY

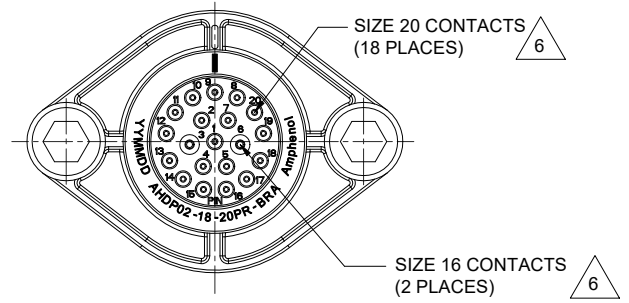

NOTES: UNLESS OTHERWISE SPECIFIED

1. MATERIAL:

HOUSING: THERMOPLASTIC; BLACK
 SEAL: SILICONE RUBBER
 THREADED INSERT: STAINLESS STEEL

2. MODIFICATIONS: BACKSHELL RING ADAPTER (BRA);

REDUCED DIA. WIRE SEAL;
 SEALED PANEL MOUNT

3. SPECIFICATIONS:

- 3.1 OPERATING TEMPERATURE: -55°C TO +125°C.
- 3.2 DIELECTRIC WITHSTANDING VOLTAGE: LESS THAN 2 MILLIAMPS CURRENT LEAKAGE @ 1500 VOLTS AC.
- 3.3 INSULATION RESISTANCE: 1000 MEGOHM MIN @ 25°C.
- 3.4 MOISTURE RESISTANCE:
 IP68 (IM OF WATER FOR A PERIOD OF 24 HOURS, MATED CONDITION);
 IP69K (MATED CONDITION)
- 3.5 MATING CYCLE DURABILITY: 100 CYCLES
- 3.6 RoHS COMPLIANT

4. MATING PART: AHDP06-18-20S* (* = SEAL TYPE)

5. ALL DIMENSIONS ARE FOR REFERENCE USE ONLY.

6. CONTACT SIZE AND WIRE RANGE:

CONTACT SIZE	MIN. INSUL O.D.	MAX. INSUL O.D.	TYPICAL WIRE RANGE	CURRENT RATING
16	1.35 mm (.053 in)	3.05 mm (.120 in)	14-20 AWG (2.0-0.5mm ²)	13 AMPS
20	1.02 mm (.040 in)	2.41 mm (.095 in)	16-22 AWG (1.5-0.35mm ²)	7.5 AMPS

M5X0.8-6H 8mm(2X) DEEP THREADED INSERT

RECOMMENDED TORQUE VALUES: 1.9-2.2 N.m

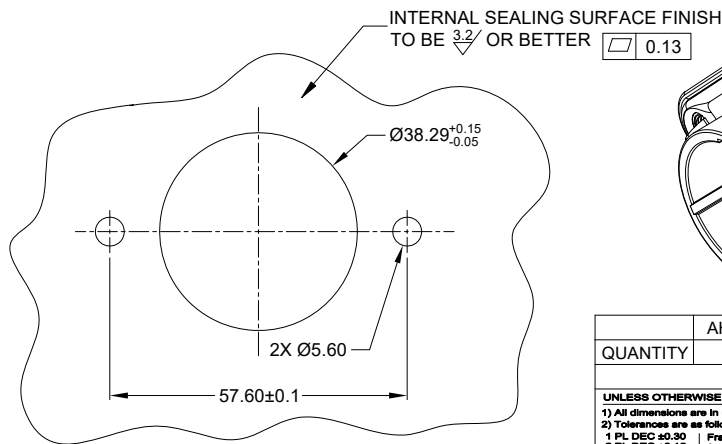

RECOMMENDED PANEL MOUNTING HOLE

RECOMMENDED PANEL THICKNESS: 1.6 TO 4.7MM

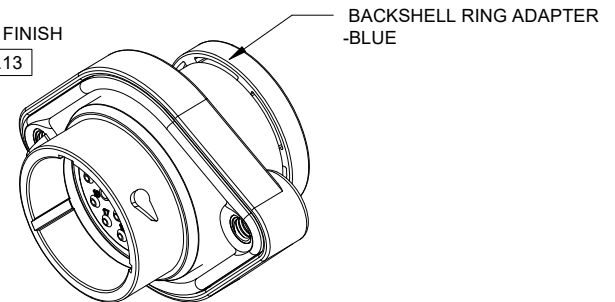

QUANTITY	AHDP02-18-20PR-BRA	DESCRIPTION	ITEM
MATERIALS LIST			
UNLESS OTHERWISE SPECIFIED		SIGNATURES DATE	
1) All dimensions are in metric(mm).		DRAWN: VITOLJ 28MAR22	
2) Tolerances are as follows:		CHECKED: SULENZHANG 29MAR22	
1 PL DEC ±0.30 Fractions ±1/64		ENGINEER:	
2 PL DEC ±0.15 Angles ±1°		APPROVAL: TOMMY 30JUL20	
3 PL DEC ±0.06		CUSTOMER:	
3) Note reference =		MATERIAL SPECIFICATIONS:	
		WEIGHT: 53.9g	
PROCESS SPECIFICATIONS:		THIS DRAWING IS SUPPLIED FOR INFORMATION ONLY. DESIGN FEATURES, SPECIFICATIONS AND PERFORMANCE DATA SHOWN HEREON ARE THE PROPERTY OF THE AMPHENOL CORPORATION. NO RIGHTS OF REPRODUCTION ARE IMPLIED. ALL DIMENSIONS ARE SUBJECT TO NORMAL MANUFACTURING VARIATIONS.	
NEXT ASSY:		SCALE: NONE	
		SIZE: B C- DWG NO: AHDP02-18-20PR-BRA REVISION: A1	
		SHEET 1 OF 1	

TITLE: 20 POS. RECEPTACLE, PIN, PANELMATE AHP SIZE 18, RD SEAL, BRA
 DWG NO.: AHDP02-18-20PR-BRA
 REV: A1
 SH: 1
 OF: 1