

FP-XMFTB

Extra Medium Flat Panel Flush Mount with Tilt

Product Features:

Holds most 32" – 52" flat panels

Maximum flat panel hole pattern – 616mm x 400mm

Adjustable tilt -5° to +15°

Distance from wall to back of the flat panel – 2.3"

Load capacity – 120 lbs

Black powder coat finish

Available in silver finish (FP-XMFT)

Product Specifications:

(for Architects & Engineers)

The wall flush with tilt mount for the extra medium flat panel display shall be the Video Mount Products (VMP) model FP-XMFT. The mount shall be designed to attach to at least 2 studs up to 24" apart or other suitable support surface. The mount shall be primarily composed of formed steel and shall incorporate arc welds and security screws. The mount shall be a universal style mount capable of mounting to all 32" – 52" flat panels. The tilt rails shall be capable of accommodating a maximum hole pattern of 616 mm wide and 400 mm tall. The mount shall be capable of tilting from -5° to +15°. The load capacity shall be 120 lbs.

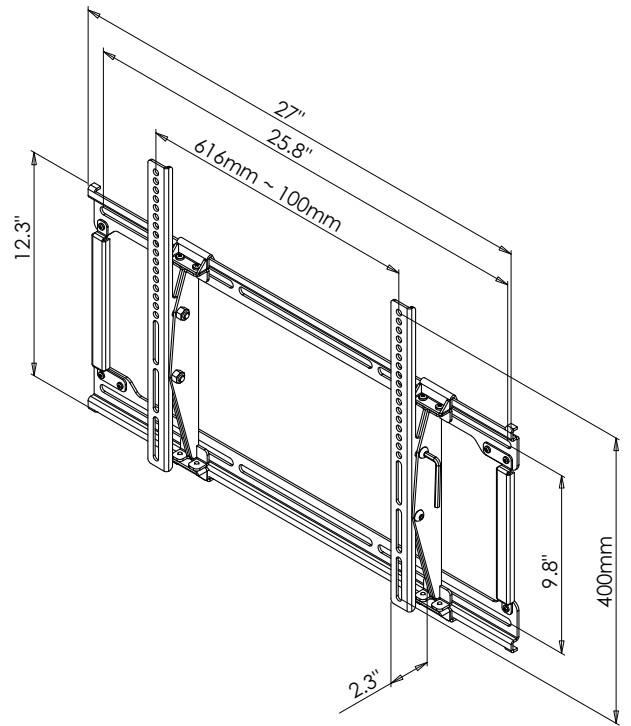

Video Mount Products

345 Log Canoe Circle

Stevensville, MD 21666

Toll Free: 877.281.2169

Telephone: 410.643.6390

Facsimile: 410.643.6615

www.videomount.com

VMP
VIDEO MOUNT PRODUCTS