

LOC		DIST		REVISIONS			
DF	DO	REV	DATE	DESCRIPTION	DATE	OWN	APVD
A	RELEASED		7-28-08			CT	RL

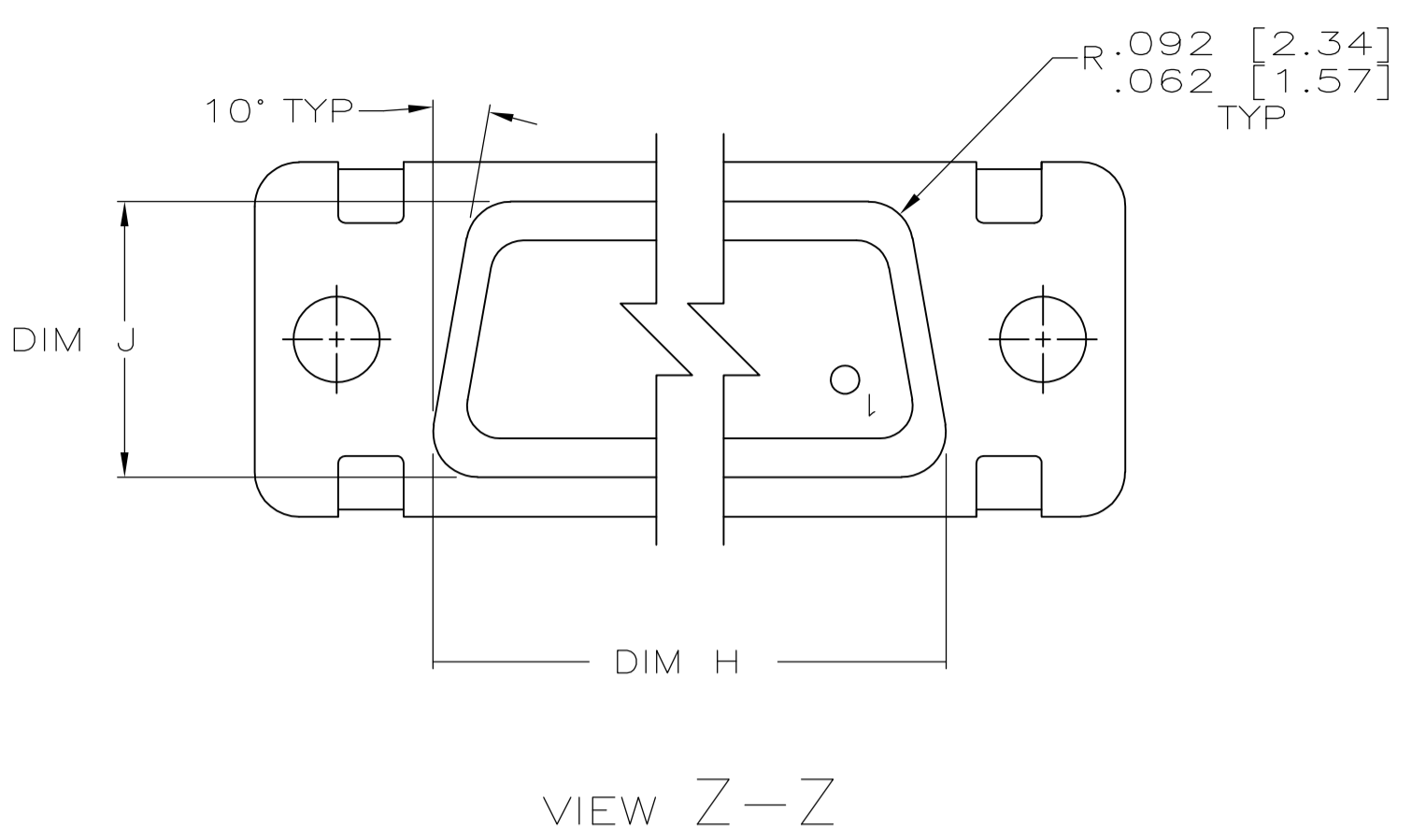

- ⚠ FOR RECOMMENDED P.C. BOARD LAYOUT. TRUE POSITION TOLERANCE FOR P.C. BOARD LAYOUT IS .010 [0.25] AT MAX MATERIAL CONDITION. SUGGESTED BOARD THICKNESS IS .094 [2.39]
- 2. THE CONNECTORS DESCRIBED IN THIS DOCUMENT WILL MATE WITH ANY PLUG CONNECTOR WITH THE SAME INSERT ARRANGEMENT.
- ⚠ MARKED WITH .047 [1.19]-.062 [1.57] HIGH CHARACTERS. FAR SIDE REFERS TO THE WIDE SIDE OF THE KEYSTONE. NEAR SIDE REFERS TO THE NARROW SIDE OF THE KEYSTONE. IF THE FRONT SHELL IS TOO SMALL FOR MFG NAME, BRAND NAME OR LOGO, MFG PART NUMBER AND DATE CODE, THEN SPLIT AS FOLLOWS:
  - A. MFG PART NUMBER ON REAR SHELL, NEAR SIDE.
  - B. MFG NAME, BRAND NAME OR LOGO AND DATE CODE ON FRONT SHELL, NEAR SIDE.
- ⚠ POINT OF ELECTRICAL ENGAGEMENT - AS MEASURED WITH A .0390 [0.991]-.0393 [0.998] DIA SQUARE ENDED TEST PIN.
- ⚠ SPACERS (QTY 2) ARE SUPPLIED WITH CONNECTORS (NOT ATTACHED TO THE CONNECTOR).

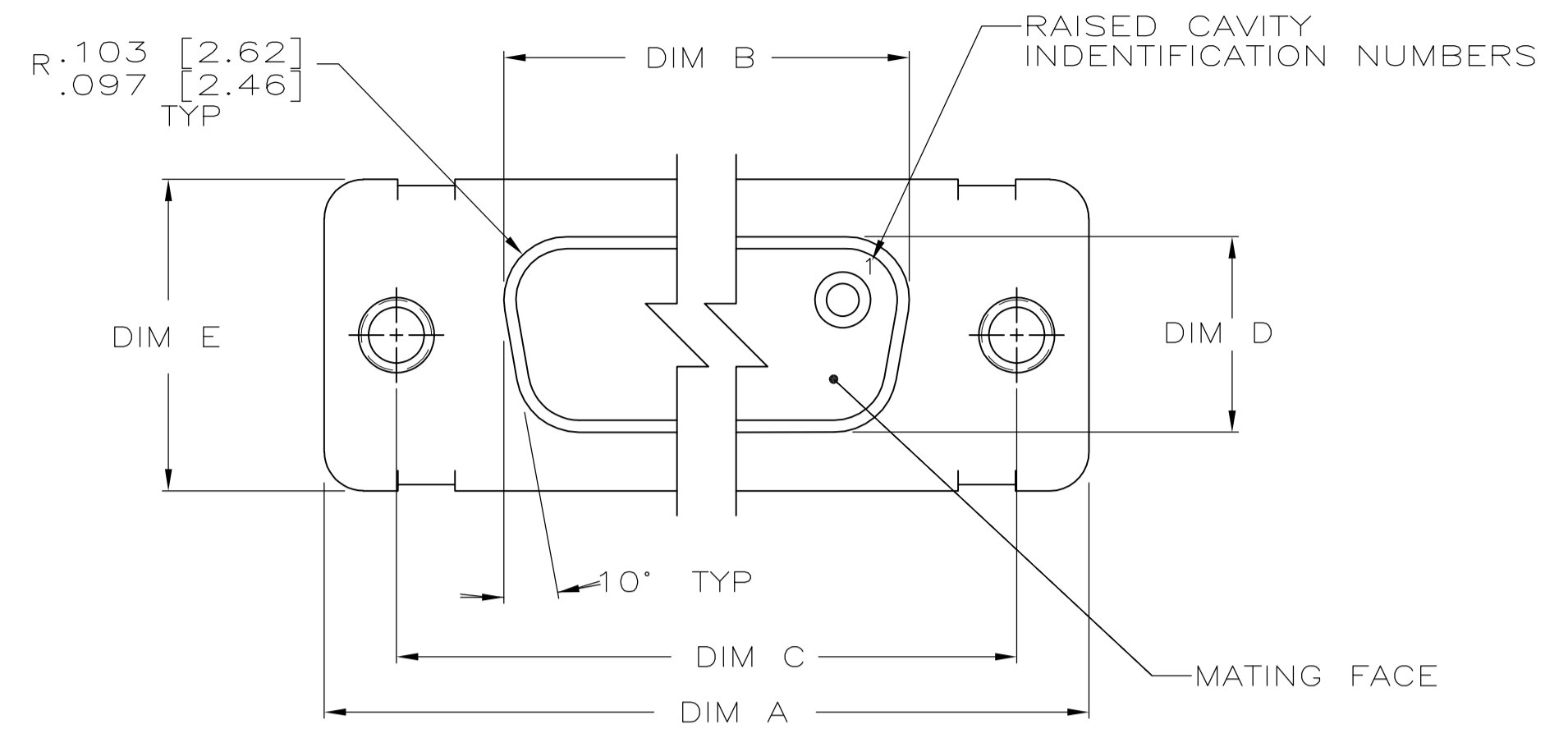
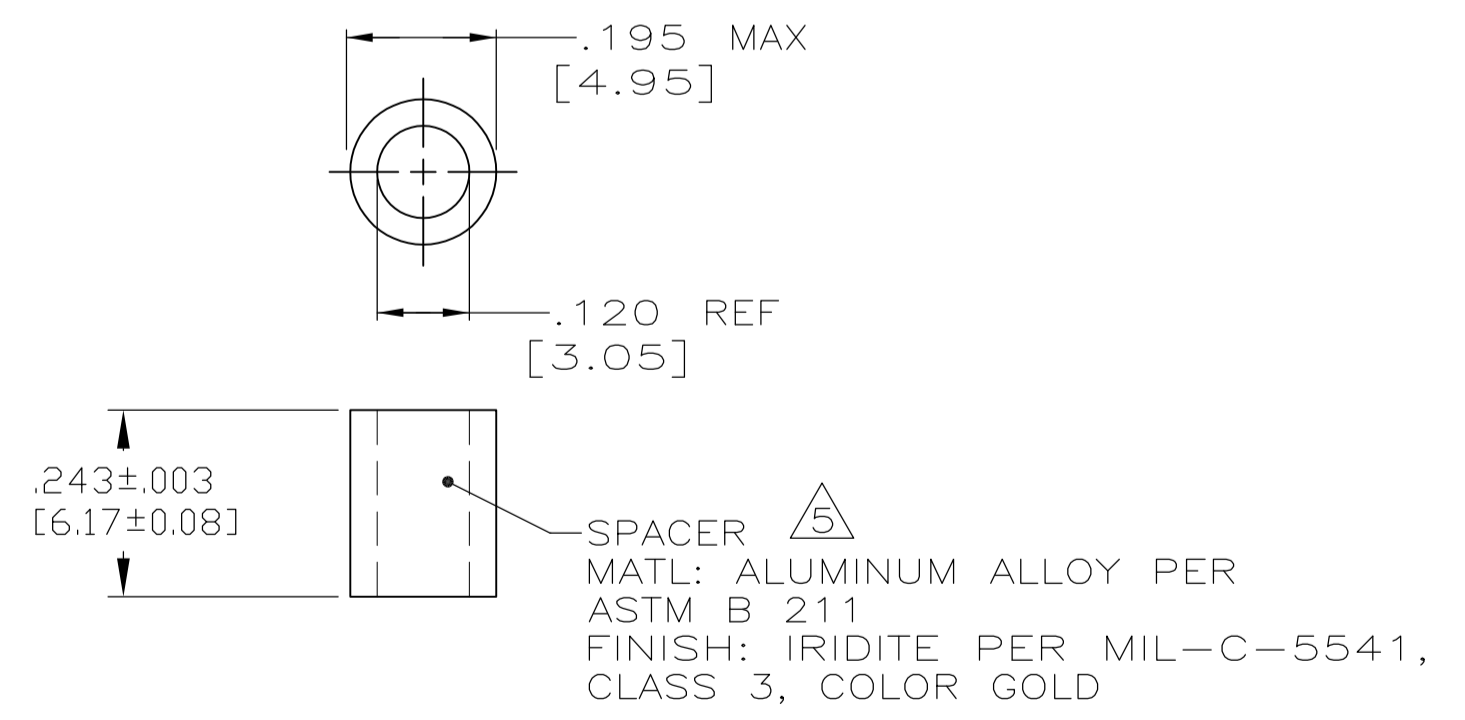
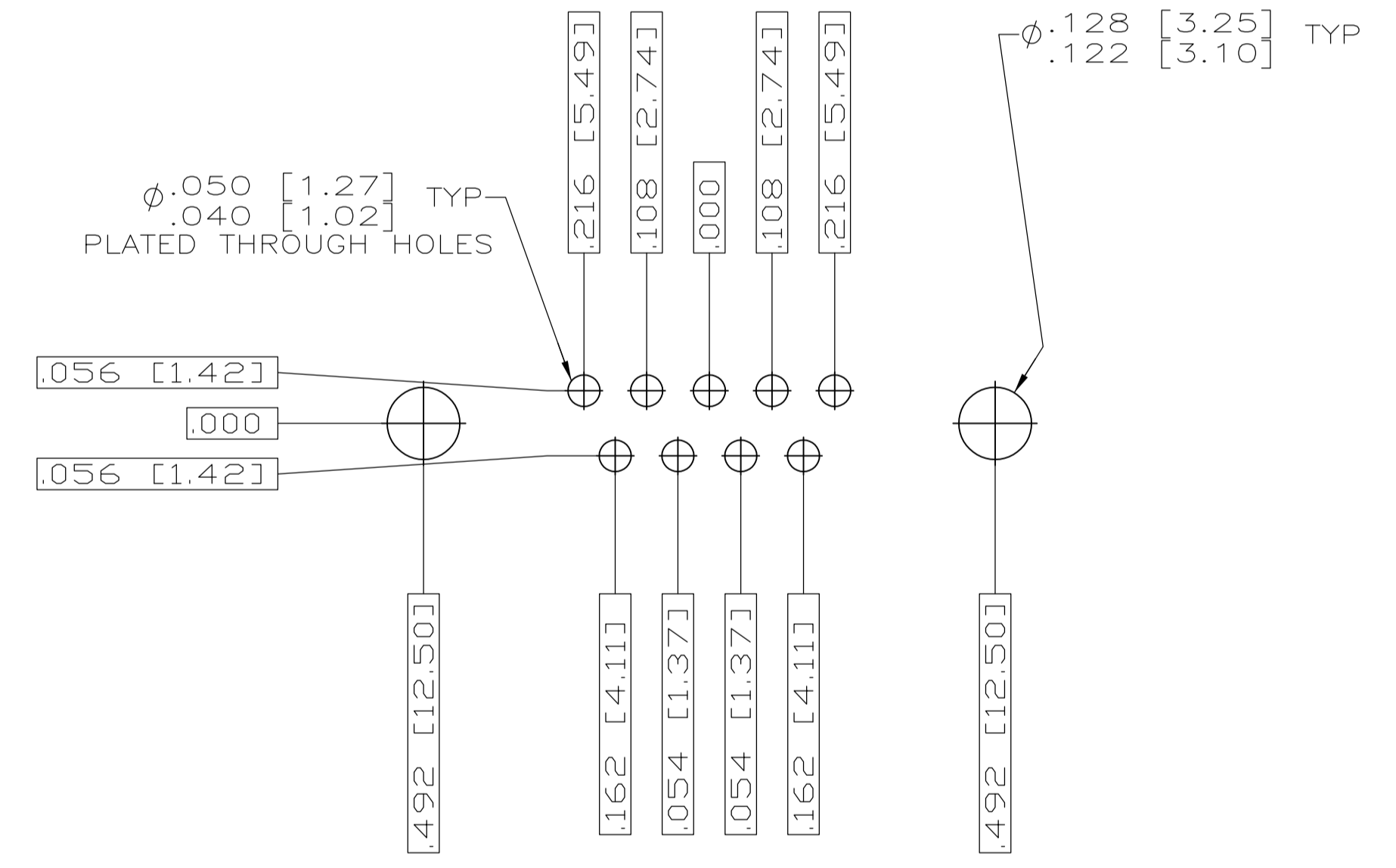
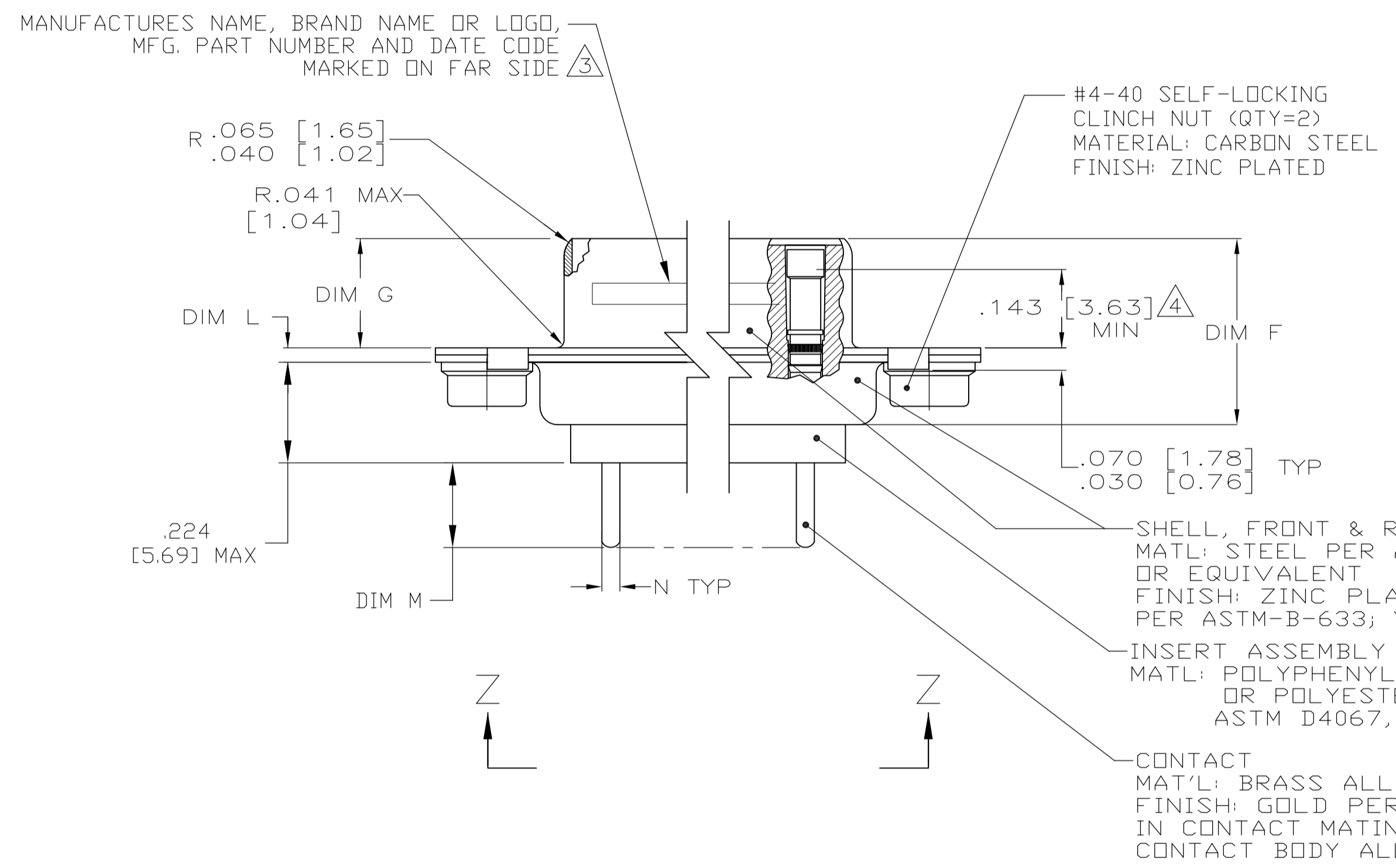

.033 [0.84] .027 [0.69]	.176 [4.47] .136 [3.45]	.040 [1.02] .020 [0.51]	.432 [10.97] .412 [10.46]	.769 [19.53] .749 [19.02]	.248 [6.30] .238 [6.05]	.439 [11.15] .419 [10.64]	.509 [12.93] .479 [12.17]	.316 [8.03] .306 [7.77]	.989 [25.12] .979 [24.87]	.648 [16.46] .638 [16.21]	1.228 [31.19] 1.198 [30.43]	MS18273-1	9	1	1996840-1
N	M	L	J	H	G	F	E	D	C	B	A	INSERT ARRANGEMENT	NO OF POS	SHELL SIZE	PART NUMBER

THIS DRAWING IS A CONTROLLED DOCUMENT.

DIMENSIONS: DIMENSIONS IN INCHES [mm]

TOLERANCES UNLESS OTHERWISE SPECIFIED:

0 PL	±	-
1 PL	±	-
2 PL	±	-
3 PL	±	-
4 PL	±	-
ANGLES	±	-

MATERIAL: SEE CALLOUTS

FINISH: SEE CALLOUTS

WEIGHT: -

CUSTOMER DRAWING

SCALE: 4:1

SHEET: 1 OF 1

REV: A

DW: C.C. THOMAS 7-28-08  
CHK: R. LEASE 7-28-08  
APVD: R. LEASE 7-28-08

Tyco Electronics Corporation  
Harrisburg, PA 17105-3608

AMPLIMITE RECEPTACLE ASSY, LOW PROFILE  
SIZE 20 POSTED P.C. BOARD CONTACTS  
SERIES 109, SIZE 1

SIZE: A1  
CAGE CODE: 00779  
DRAWING NO: 1996840