

## Evaluation Board for the **ADGS1612** SPI Interface, 1 $\Omega$ $R_{ON}$ , $\pm 5$ V, 12 V, 5 V, 3.3 V, Mux Configurable, Quad SPST Switch

### FEATURES

**SPI interface with error detection**  
**Includes CRC, invalid read/write address, and SCLK count error detection**  
**Analog supply voltages**  
Dual-supply:  $\pm 3.3$  V to  $\pm 8$  V  
Single-supply: 3.3 V to 16 V  
**PC control in conjunction with the evaluation software**  
**[EVAL-SDP-CB1Z](#) SDP**

### PACKAGE CONTENTS

**EVAL-ADGS1612SDZ**

### DOCUMENTS NEEDED

**[ADGS1612](#) data sheet**

### EQUIPMENT NEEDED

**[EVAL-SDP-CB1Z](#) controller board**  
**[ACE](#) software with EVAL-ADGS1612SDZ plug-in**  
**DC voltage source**  
 $\pm 5.5$  V for dual-supply  
12 V, 5V, 3.3V for single-supply  
**Optional digital logic supply: 3.3 V**  
**Analog signal source**  
**Method to measure voltage, such as a digital multimeter (DMM)**

### GENERAL DESCRIPTION

The EVAL-ADGS1612SDZ is the evaluation board for the [ADGS1612](#). The [ADGS1612](#) is an iCMOS, quad single-pole, single-throw (SPST) switch controlled by a serial peripheral interface (SPI). The SPI has robust error detection features. These are cyclic redundancy check (CRC) error detection, invalid read/write address detection, and serial clock (SCLK) count error detection. It is possible to daisy-chain multiple [ADGS1612](#) devices together. This enables the configuration of multiple devices with a minimal amount of digital lines. The [ADGS1612](#) also supports burst mode that decreases the time between SPI commands.

Figure 1 shows the EVAL-ADGS1612SDZ in a typical evaluation setup. The EVAL-ADGS1612SDZ is controlled by the system demonstration platform (SDP) which connects to a PC via a USB port. The [ADGS1612](#) is on the center of the evaluation board and wire screw terminals are provided to connect to each of the source and drain pins. Three screw terminals power the device and a fourth terminal provides users with a defined digital logic supply voltage, if required. Alternatively, the digital logic supply voltage can be supplied from the SDP.

Full specifications on the [ADGS1612](#) are available in the [ADGS1612](#) data sheet available from Analog Devices, Inc., and should be consulted in conjunction with this user guide when using the evaluation board.

The evaluation board interfaces to the USB port of a PC via the SDP board. The [EVAL-SDP-CB1Z](#) board ([SDP-B](#) controller board) is available to order on the Analog Devices website at [www.analog.com](http://www.analog.com).

## TABLE OF CONTENTS

Features .....	1	Link Options .....	4
Package Contents .....	1	Evaluation Board Software .....	5
Documents Needed .....	1	Installing the Software .....	5
Equipment Needed .....	1	Initial Set Up .....	5
General Description .....	1	Block Diagram And Description .....	5
Revision History .....	2	Memory Map .....	6
ADGS1612 Evaluation Board Layout .....	3	Evaluation Board Schematics and Artwork .....	7
Evaluation Board Hardware .....	4	Ordering Information .....	11
Power Supplies .....	4	Bill of Materials .....	11
Input Signals .....	4		

## REVISION HISTORY

1/2018—Revision 0: Initial Version

### ADGS1612 EVALUATION BOARD LAYOUT

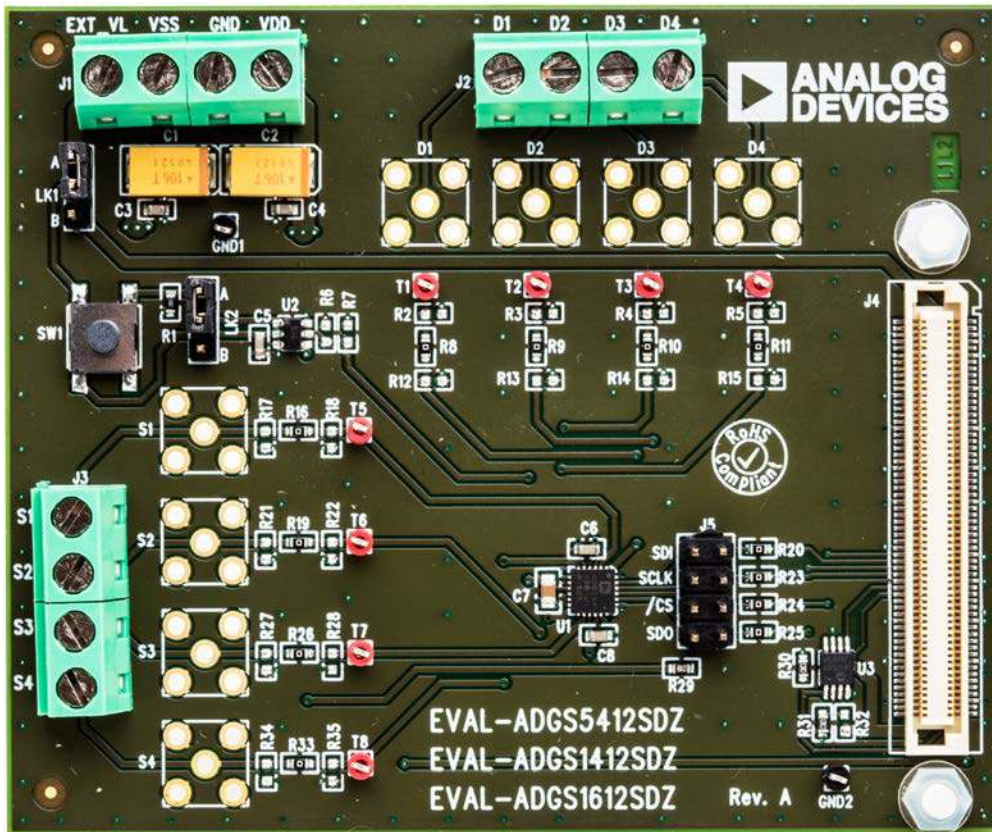

Figure 1.

16263-001

## EVALUATION BOARD HARDWARE

### POWER SUPPLIES

Connector J1 provides access to the supply pins of the [ADGS1612](#). VDD, GND, and VSS on J1 link to the corresponding pins on the [ADGS1612](#). For dual-supply voltages, the evaluation board can be powered from  $\pm 3.3$  V to  $\pm 8$  V. For single-supply voltages, the GND and VSS terminals must connect together and power the evaluation board with 3.3 V to 16 V. Additionally, 3.3 V is supplied to the  $V_L$  pin of the [ADGS1612](#) by the SDP when Link LK1 is in Position B. When controlling the [ADGS1612](#) by another method other than the SDP, supply between 2.7 V and 5.5 V to the  $V_L$  pin of the [ADGS1612](#) via the EXT\_VL screw terminal input on J1. LK1 must be in Position A.

### INPUT SIGNALS

Two screw connectors, J2 and J3, are provided to connect to both the source and drain pins of the [ADGS1612](#). Additional subminiature Version B (SMB) connector pads are available if extra connections are required.

Each trace on the source and drain side includes two sets of 0603 pads, which can place a load on the signal path to ground.

**Table 2. Link Functions**

Link Number	Function
LK1	This link selects the source of the $V_L$ voltage supplied to the <a href="#">ADGS1612</a> . Position A selects EXT_VL from J1. Position B selects 3.3 V from the SDP.
LK2	This link selects the source of the digital input of the <a href="#">ADG819</a> which is used to perform a hardware reset of the <a href="#">ADGS1612</a> . Position A indicates the SW1 push button performs a hardware reset. Position B indicates the SDP can perform a hardware reset.

A  $0 \Omega$  resistor is placed in the signal path and can be replaced with a user defined value. The resistor, combined with the 0603 pads, can create a simple resistor-capacitor (RC) filter.

### LINK OPTIONS

A number of link options are provided on the EVAL-ADGS1612SDZ board that must be set for the required operating conditions before using. Table 1 describes the positions of the links to control the evaluation board via the SDP board using a PC and external power supplies. The functions of these link options are described in detail in Table 2.

When using the SDP in conjunction with the EVAL-ADGS1612SDZ, LK1 must be in Position B to avoid damage to the SDP.

**Table 1. Link Options for SDP Control (Default)**

Link Number	Option
LK1	B
LK2	B

## EVALUATION BOARD SOFTWARE

### INSTALLING THE SOFTWARE

The EVAL-ADGS1612SDZ evaluation board uses the Analog Devices [Analysis Control Evaluation \(ACE\)](#) software. ACE is a desktop software application that allows the evaluation and control of multiple evaluation systems.

The ACE installer installs the necessary SDP drivers and .NET Framework 4 by default. Install ACE before connecting the SDP. The ACE software and access to full instructions on how to install and use ACE can be found on the Analog Devices website.

After the installation is finished, the EVAL-ADGS1612SDZ evaluation board plug-ins appear when opening ACE.

### INITIAL SET UP

To set up the evaluation board, complete the following steps:

1. Connect the evaluation board to the SDP board and connect the SDP board to the computer via a USB cable.
2. Power the evaluation board as described in the Power Supplies section.
3. Run the ACE application. The EVAL-ADGS1612SDZ board plug-ins appear in the attached hardware section of the **Start** tab.
4. Double-click on the evaluation board plug-in to open the evaluation board view seen in Figure 2.
5. The chip block diagram can be accessed by double-clicking on the [ADGS1612](#) chip (see Figure 2). This view provides a basic representation of functionality of the evaluation board. The main functions are labeled in Figure 3.

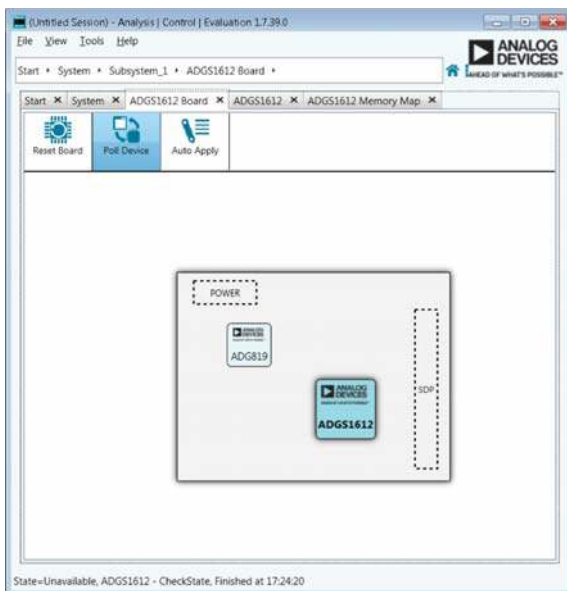

Figure 2. Evaluation Board View of the EVAL-ADGS1612SDZ

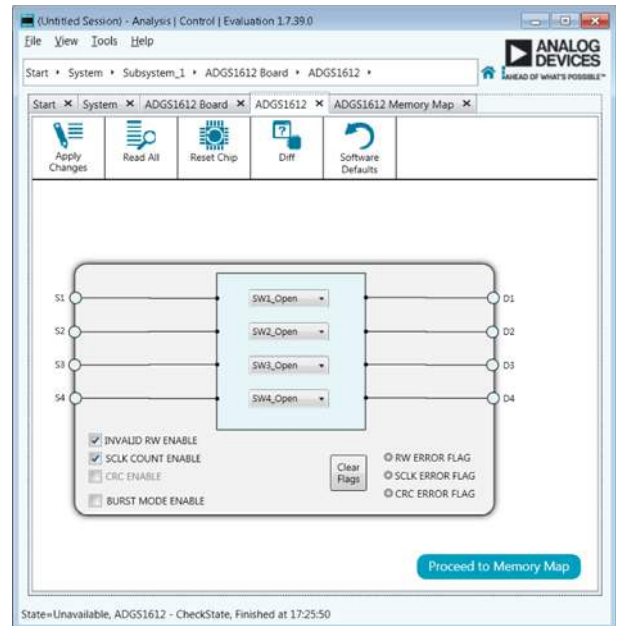

Figure 3. Chip Block Diagram View for the ADGS1612

### BLOCK DIAGRAM AND DESCRIPTION

The EVAL-ADGS1612SDZ software is organized so that it appears similar to the functional block diagram shown in the data sheet. In this way, it is easy to correlate the functions on the EVAL-ADGS1612SDZ board with the full description of each block, register, and settings is given in the [ADGS1612](#) data sheet.

Some of the blocks and their functions are described here as they pertain to the evaluation board. The full screen block diagram, shown in Figure 4, describes the functionality of each block.

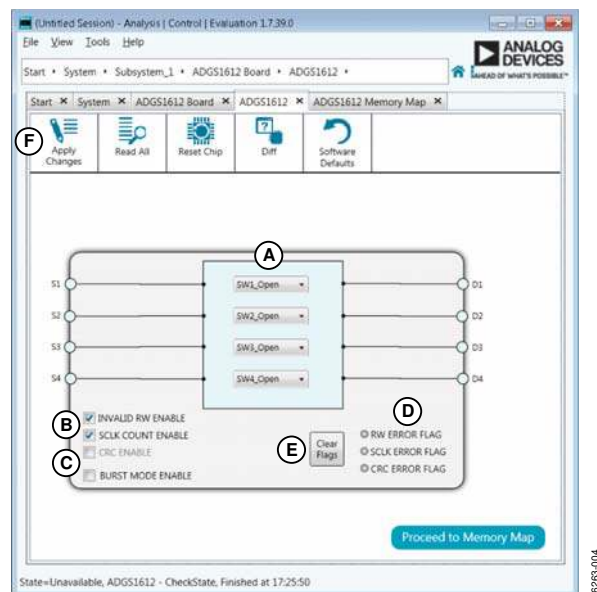

Figure 4. EVAL-ADGS1612SDZ Block Diagram with Labels

Table 3. Block Diagram Functions

Label	Function
A	The drop-down menus configure SW1 to SW4 as open or closed.
B	The <b>INVALID RW ENABLE</b> , <b>SCLK COUNT ENABLE</b> , and <b>CRC ENABLE</b> checkboxes enable or disable the error detection features on the SPI interface.
C	The <b>BURST MODE ENABLE</b> checkbox enables or disables burst mode.
D	The <b>RW ERROR FLAG</b> , <b>SCLK ERROR</b> , and <b>CRC ERROR FLAG</b> indicators illuminate red if flags assert in the error flags register.
E	The <b>Clear Flags</b> button clears the error flags register.
F	The <b>Apply Changes</b> button applies all modified values to the devices.

**Memory Map**

All registers are fully accessible from the memory map tab; this allows registers to be edited at a bit level (see Figure 5 and Figure 6). The bits shaded in dark gray are read only bits and cannot be accessed from ACE; all other bits are toggled. The **Apply Changes** button transfers data to the device.

All changes here correspond to the block diagram; for example, if the internal register bit is enabled, it displays as enabled on the block diagram. Any bits or registers that are bold are modified values that have not been transferred to the evaluation board. After clicking **Apply Changes**, the data is transferred to the evaluation board.

Registers				
+/-	Address (Hex)	Name	Data (Hex)	Data (Binary)
+	0001	* SW_DATA	01	0 0 0 0 0 0 0 0 0 1
+	0002	ERR_CONFIG	06	0 0 0 0 0 0 0 1 1 0
+	0003	* ERR_FLAGS	00	0 0 0 0 0 0 0 0 0 0
+	0005	BURST_EN	00	0 0 0 0 0 0 0 0 0 0
+	000B	SOFT_RESETB	00	0 0 0 0 0 0 0 0 0 0
+	0025	DAISY_CHAIN_EN	00	0 0 0 0 0 0 0 0 0 0
+	006C	ERR_FLAGS_RESET	A9	1 0 1 0 1 0 0 0 0 1

Figure 5. ADGS1612 Memory Map

Registers				
+/-	Address (Hex)	Name	Data (Hex)	Data (Binary)
+	<b>0001</b>	<b>* SW_DATA</b>	09	0 0 0 0 0 0 1 0 0 1
+	0002	ERR_CONFIG	06	0 0 0 0 0 0 0 1 1 0
+	0003	* ERR_FLAGS	00	0 0 0 0 0 0 0 0 0 0
+	0005	BURST_EN	00	0 0 0 0 0 0 0 0 0 0
+	000B	SOFT_RESETB	00	0 0 0 0 0 0 0 0 0 0
+	0025	DAISY_CHAIN_EN	00	0 0 0 0 0 0 0 0 0 0
+	006C	ERR_FLAGS_RESET	A9	1 0 1 0 1 0 0 0 0 1

Figure 6. ADGS1612 Memory Map with Unapplied Changes in the SW\_DATA Register

EVALUATION BOARD SCHEMATICS AND ARTWORK

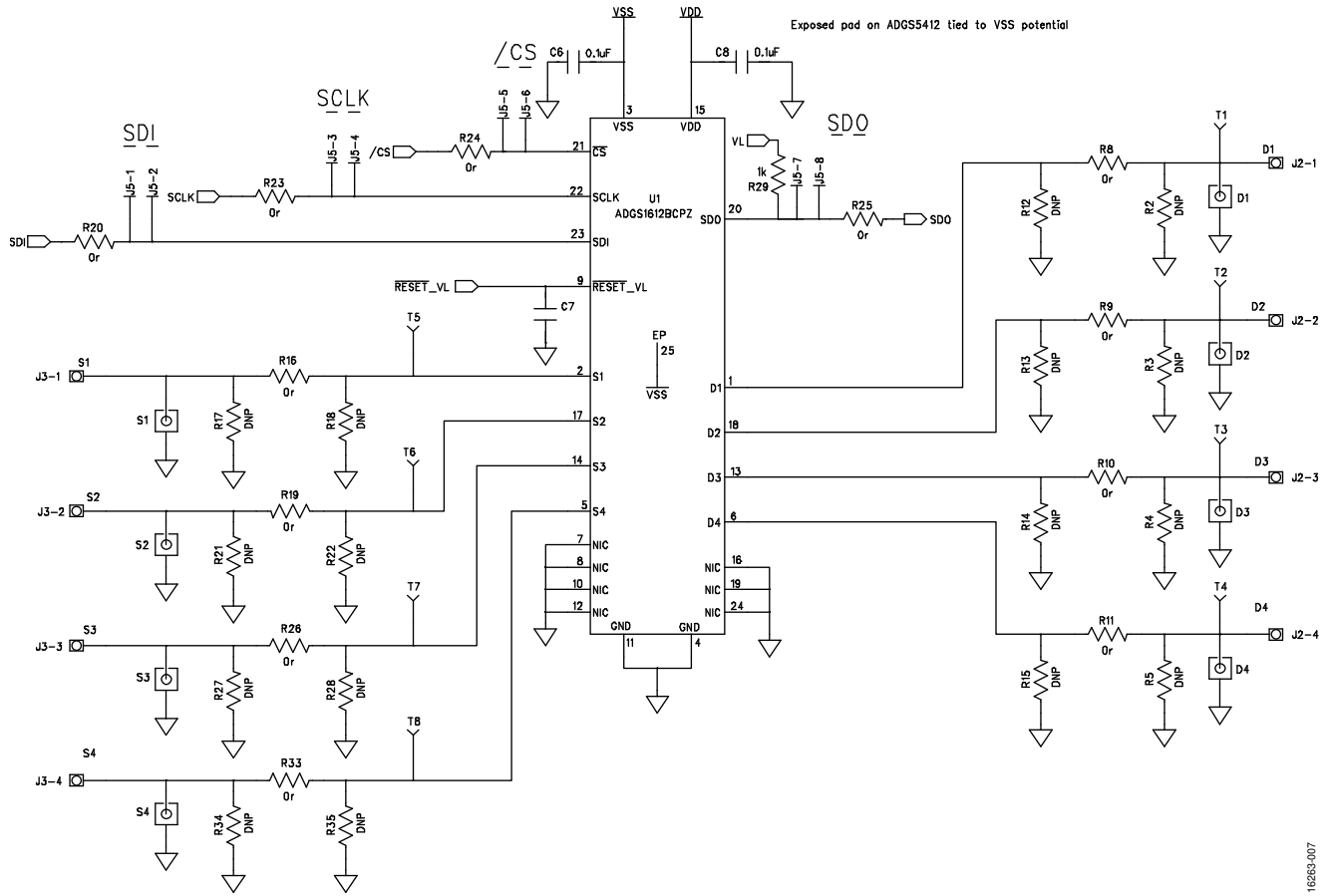

Figure 7. EVAL-ADGS1612SDZ Schematic 1

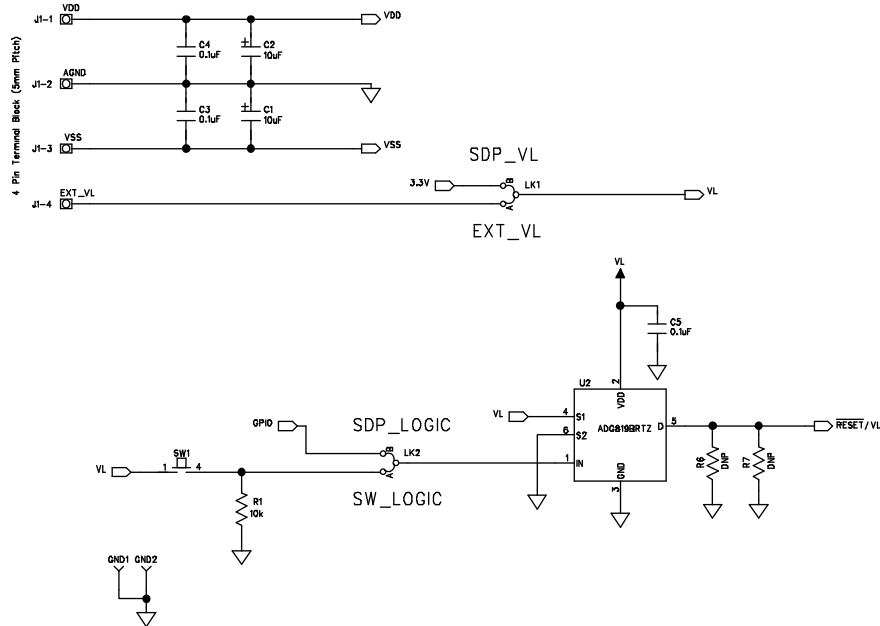

Figure 8. EVAL-ADGS1612SDZ Schematic 2

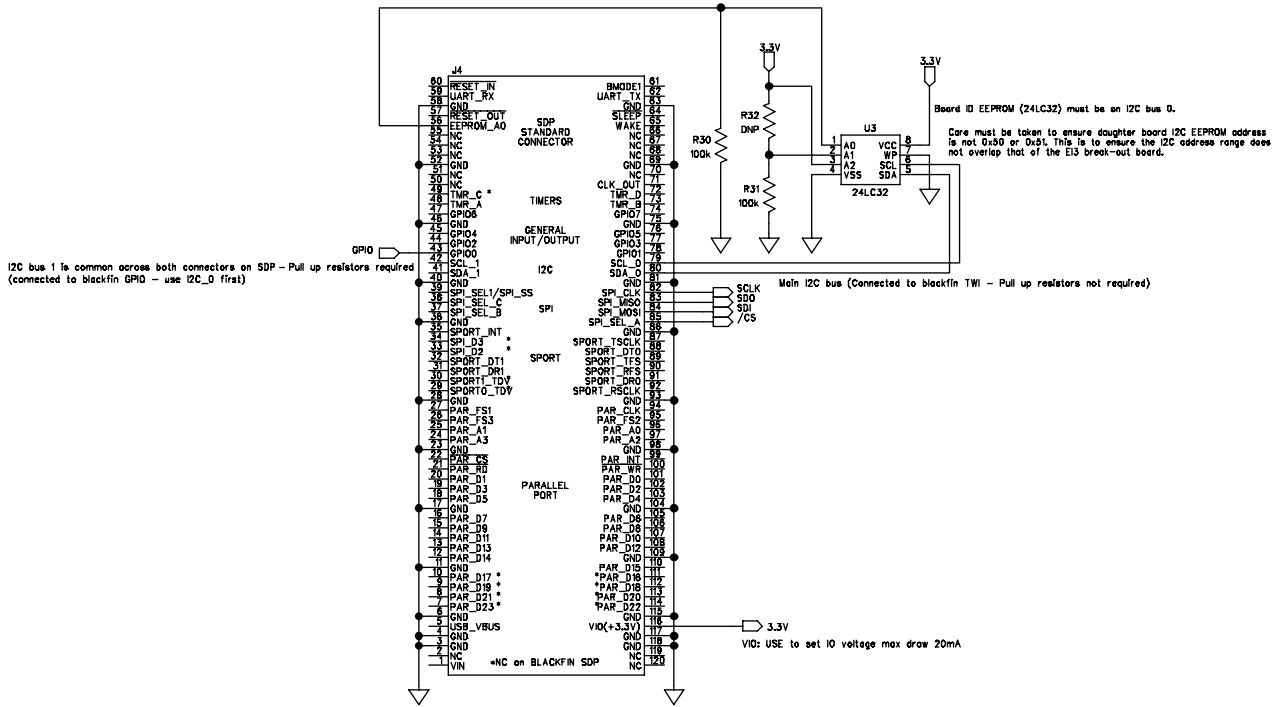

Figure 9. EVAL-ADGS1612SDZ Schematic 3

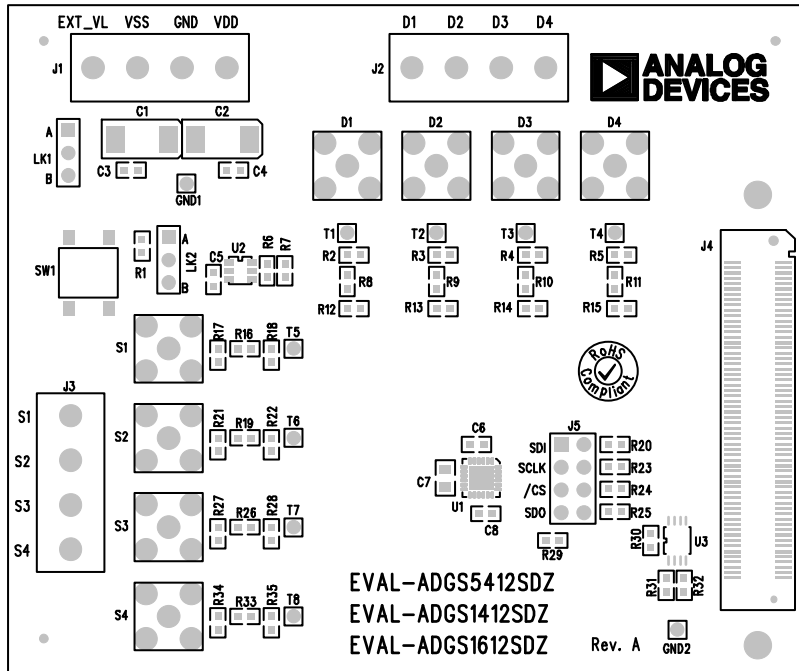

Figure 10. EVAL-ADGS1612SDZ Silk Screen



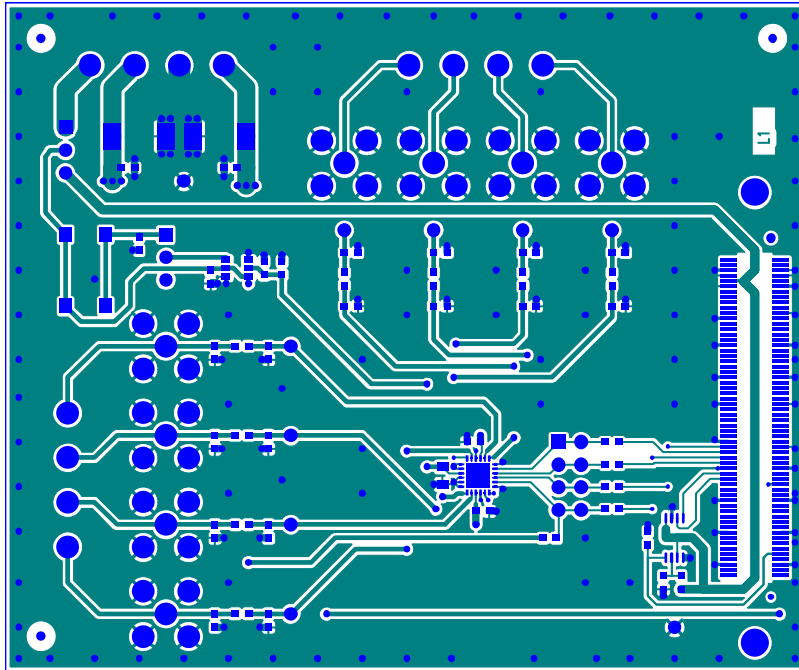

Figure 11. EVAL-ADGS1612SDZ Top Layer

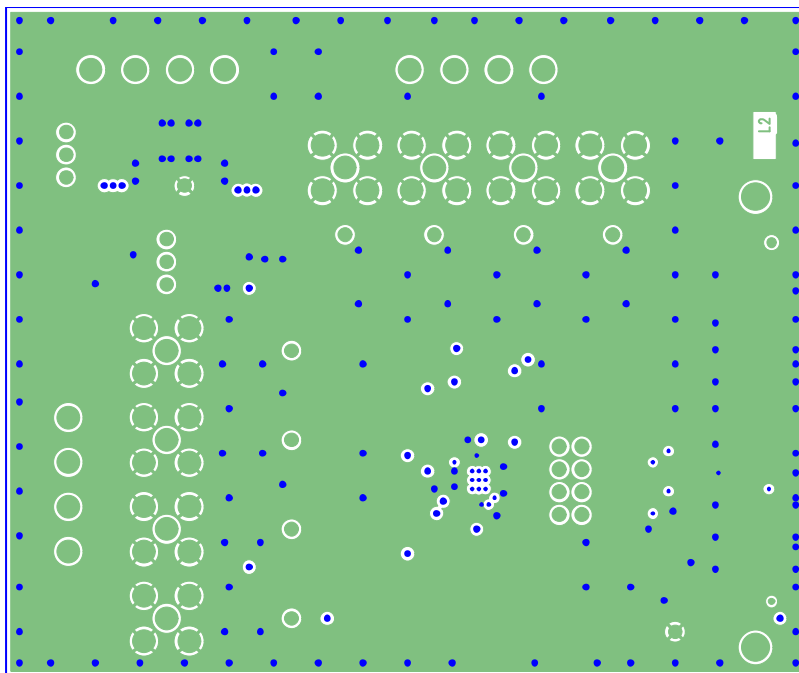
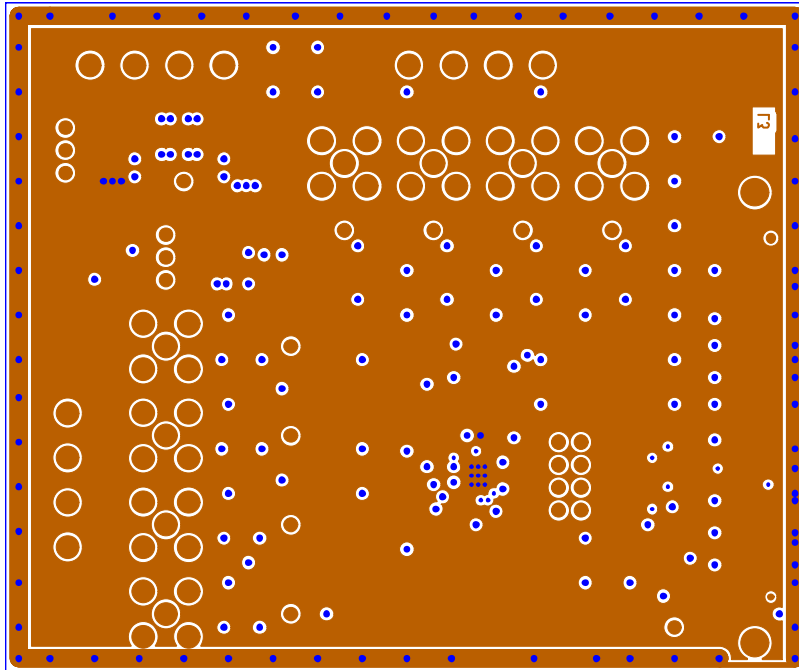
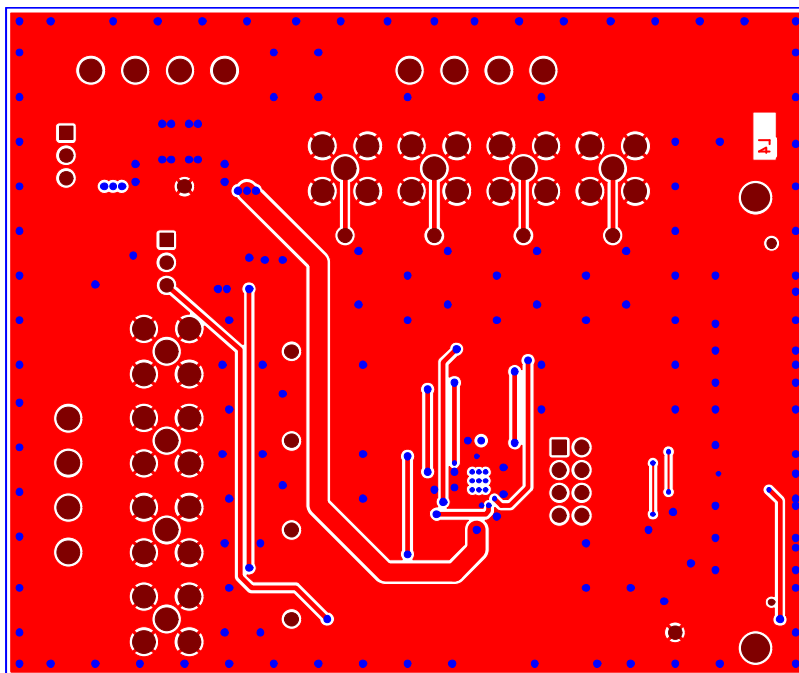

Figure 12. EVAL-ADGS1612SDZ Layer 2



16283-013

Figure 13. EVAL-ADGS1612SDZ Layer 3



16283-014

Figure 14. EVAL-ADGS1612SDZ Bottom Layer

# ORDERING INFORMATION

## BILL OF MATERIALS

Table 4.

Reference Designator	Description
C1 to C2	50 V tantalum capacitors, 10 µF, D size
C3 to C6, C8	50 V, X7R multilayer ceramic capacitors, 0.1 µF, 0603
C7	Capacitor, 10 µF, 0805, 16 V
D1 to D4	Not placed
S1 to S4	Not placed
T1 to T8	Red test points
GND1, GND2	Black test points
J1 to J3	4-pin terminal blocks, 5 mm pitch
J4	120-way connector, 0.6 mm pitch
J5	Through hole, header, 4 × 2, 2.54 mm
LK1, LK2	3-pin single inline (SIL) header and shorting links
R2 to R7, R12 to R15, R17, R18, R21, R22, R27, R28, R32, R34, R35	Not placed
R8 to R11, R16, R19, R20, R23 to R26, R33	Resistors, 0 Ω, 0603, 1%
R1	Resistor, 10 kΩ, 0.063 W, 1%, 0603
R29	Resistor, 1 kΩ, 0.063 W, 1%, 0603
R30, R31	Resistors, 100 kΩ, 0.063 W, 1%, 0603
SW1	Surface mount design (SMD) push button switch
U1	ADGS1612, SPI controlled, quad SPST switch
U2	ADG819, 1.8 V to 5.5 V, 2:1 multiplexer/single-pole, double throw (SPDT) switch
U3	32 kΩ, I <sup>2</sup> C serial EEPROM

I<sup>2</sup>C refers to a communications protocol originally developed by Philips Semiconductors (now NXP Semiconductors).



**ESD Caution**

**ESD (electrostatic discharge) sensitive device.** Charged devices and circuit boards can discharge without detection. Although this product features patented or proprietary protection circuitry, damage may occur on devices subjected to high energy ESD. Therefore, proper ESD precautions should be taken to avoid performance degradation or loss of functionality.

**Legal Terms and Conditions**

By using the evaluation board discussed herein (together with any tools, components documentation or support materials, the "Evaluation Board"), you are agreeing to be bound by the terms and conditions set forth below ("Agreement") unless you have purchased the Evaluation Board, in which case the Analog Devices Standard Terms and Conditions of Sale shall govern. Do not use the Evaluation Board until you have read and agreed to the Agreement. Your use of the Evaluation Board shall signify your acceptance of the Agreement. This Agreement is made by and between you ("Customer") and Analog Devices, Inc. ("ADI"), with its principal place of business at One Technology Way, Norwood, MA 02062, USA. Subject to the terms and conditions of the Agreement, ADI hereby grants to Customer a free, limited, personal, temporary, non-exclusive, non-sublicensable, non-transferable license to use the Evaluation Board FOR EVALUATION PURPOSES ONLY. Customer understands and agrees that the Evaluation Board is provided for the sole and exclusive purpose referenced above, and agrees not to use the Evaluation Board for any other purpose. Furthermore, the license granted is expressly made subject to the following additional limitations: Customer shall not (i) rent, lease, display, sell, transfer, assign, sublicense, or distribute the Evaluation Board; and (ii) permit any Third Party to access the Evaluation Board. As used herein, the term "Third Party" includes any entity other than ADI, Customer, their employees, affiliates and in-house consultants. The Evaluation Board is NOT sold to Customer; all rights not expressly granted herein, including ownership of the Evaluation Board, are reserved by ADI. CONFIDENTIALITY. This Agreement and the Evaluation Board shall all be considered the confidential and proprietary information of ADI. Customer may not disclose or transfer any portion of the Evaluation Board to any other party for any reason. Upon discontinuation of use of the Evaluation Board or termination of this Agreement, Customer agrees to promptly return the Evaluation Board to ADI. ADDITIONAL RESTRICTIONS. Customer may not disassemble, decompile or reverse engineer chips on the Evaluation Board. Customer shall inform ADI of any occurred damages or any modifications or alterations it makes to the Evaluation Board, including but not limited to soldering or any other activity that affects the material content of the Evaluation Board. Modifications to the Evaluation Board must comply with applicable law, including but not limited to the RoHS Directive. TERMINATION. ADI may terminate this Agreement at any time upon giving written notice to Customer. Customer agrees to return to ADI the Evaluation Board at that time. LIMITATION OF LIABILITY. THE EVALUATION BOARD PROVIDED HEREUNDER IS PROVIDED "AS IS" AND ADI MAKES NO WARRANTIES OR REPRESENTATIONS OF ANY KIND WITH RESPECT TO IT. ADI SPECIFICALLY DISCLAIMS ANY REPRESENTATIONS, ENDORSEMENTS, GUARANTEES, OR WARRANTIES, EXPRESS OR IMPLIED, RELATED TO THE EVALUATION BOARD INCLUDING, BUT NOT LIMITED TO, THE IMPLIED WARRANTY OF MERCHANTABILITY, TITLE, FITNESS FOR A PARTICULAR PURPOSE OR NON-INFRINGEMENT OF INTELLECTUAL PROPERTY RIGHTS. IN NO EVENT WILL ADI AND ITS LICENSORS BE LIABLE FOR ANY INCIDENTAL, SPECIAL, INDIRECT, OR CONSEQUENTIAL DAMAGES RESULTING FROM CUSTOMER'S POSSESSION OR USE OF THE EVALUATION BOARD, INCLUDING BUT NOT LIMITED TO LOST PROFITS, DELAY COSTS, LABOR COSTS OR LOSS OF GOODWILL. ADI'S TOTAL LIABILITY FROM ANY AND ALL CAUSES SHALL BE LIMITED TO THE AMOUNT OF ONE HUNDRED US DOLLARS (\$100.00). EXPORT. Customer agrees that it will not directly or indirectly export the Evaluation Board to another country, and that it will comply with all applicable United States federal laws and regulations relating to exports. GOVERNING LAW. This Agreement shall be governed by and construed in accordance with the substantive laws of the Commonwealth of Massachusetts (excluding conflict of law rules). Any legal action regarding this Agreement will be heard in the state or federal courts having jurisdiction in Suffolk County, Massachusetts, and Customer hereby submits to the personal jurisdiction and venue of such courts. The United Nations Convention on Contracts for the International Sale of Goods shall not apply to this Agreement and is expressly disclaimed.

