

NOTE:  
 1. MATERIAL:  
 HOUSING: THERMOPLASTIC POLYESTER WITH GLASS FIBER FILLED,  
 UL 94V-0, COLOR: BLACK.  
 COVER: THERMOPLASTIC POLYESTER WITH GLASS FIBER FILLED,UL 94V-0, COLOR: BLACK.  
 CONTACT: PHOSPHOR BRONZE  
 FRONT SHIELD: BRASS  
 REAR SHIELD: BRASS  
 GROUND FINGER: BRASS  
 2. FINISH:  
 CONTACT :15 MICROINCH GOLD PLATED IN CONTACT AREA.  
 150 MICROINCH-250 MICROINCH TIN PLATED ON SOLDER TAILS.  
 50 MICROINCH NICKEL UNDERPLATED OVER ALL.  
 FRONT SHIELD: 100 MICROINCH TIN PLATED ON ENTIRE WITH  
 50 MICROINCH NICKEL UNDERPLATED OVER ALL.  
 REAR SHIELD: NICKEL PLATED WITH 120 MICROINCH MINIMUM.  
 GROUND FINGER:100 MICROINCH TIN PLATED ON ENTIRE WITH  
 50 MICROINCH NICKEL UNDERPLATED OVER ALL.  
 3. PRODUCT SPECIFICATION:REFER TO PS-67857-002  
 4. PACKAGING: REFER TO PK-67857-002  
 5. TEST SUMMARY: REFER TO TS-67857-002  
 6. LEAD-FREE AND ROHS COMPLIANT PRODUCT

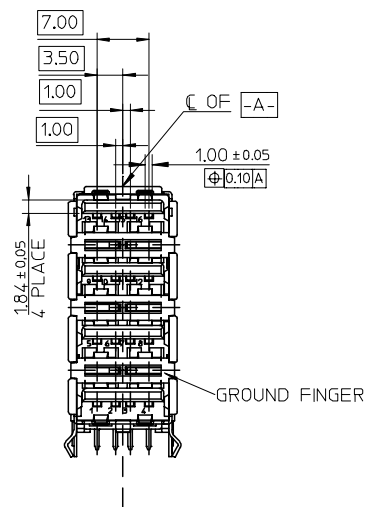

REVISED EC NO: SH2007-0796 2007/06/01 DRAWN: EKA001 2007/06/01 CHKD: APPR: WWSCHANG 2007/06/01	DESCRIPTION	QUALITY SYMBOLS	GENERAL TOLERANCES (UNLESS SPECIFIED)	DIMENSION STYLE	SCALE	DESIGN UNITS	THIRD ANGLE PROJECTION
		▽=0 ∇=0	mm INCH	MM ONLY	1.5:1	METRIC	
			4 PLACES ± --- ± ---	DRAWN BY DEQUAN	DATE 05/04/13	TITLE USB 4 STACKS	
			3 PLACES ± --- ± ---	CHECKED BY ERIC KAO	DATE 05/04/13	MOLEX INCORPORATED	
			2 PLACES ± 0.25 ± ---	APPROVED BY WWSCHANG	DATE 05/04/13	DOCUMENT NO. SD-67857-002	SHEET NO. 1 OF 2
			1 PLACE ± 0.25 ± ---	MATERIAL NO.		SEE TABLE	
			ANGULAR ± 3 °	DRAFT WHERE APPLICABLE MUST REMAIN WITHIN DIMENSIONS		THIS DRAWING CONTAINS INFORMATION THAT IS PROPRIETARY TO MOLEX INCORPORATED AND SHOULD NOT BE USED WITHOUT WRITTEN PERMISSION	

67857-0011	LEAD FREE
Molex P/N	NOTE

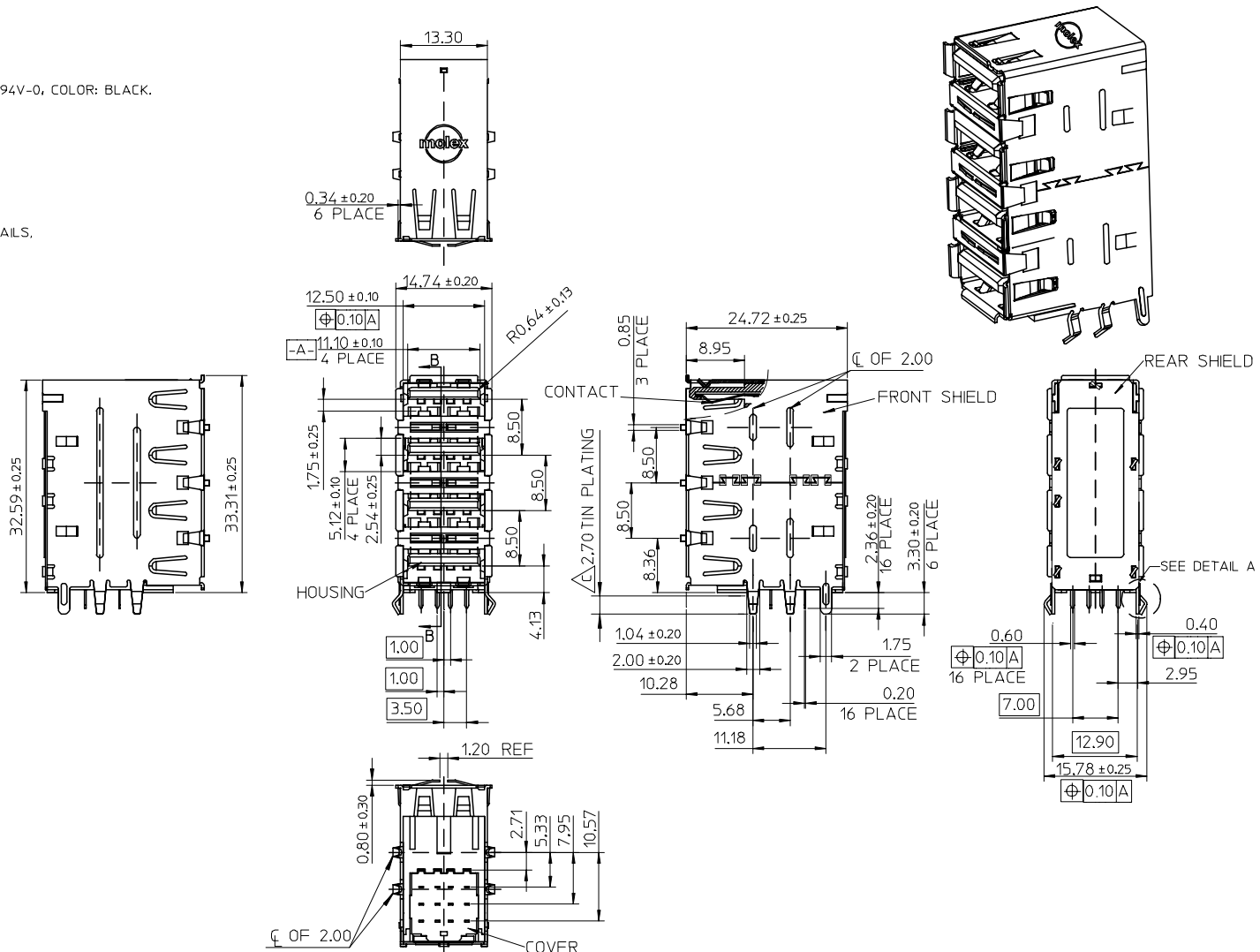
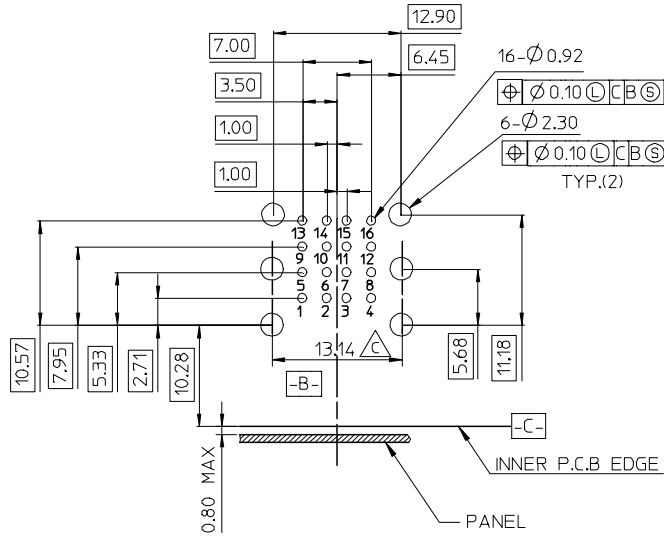

RECOMMENDED P.C.B. LAYOUT (1) (THICKNESS=1.6MM)  
(GENERAL TOLERANCE: ±0.05MM)

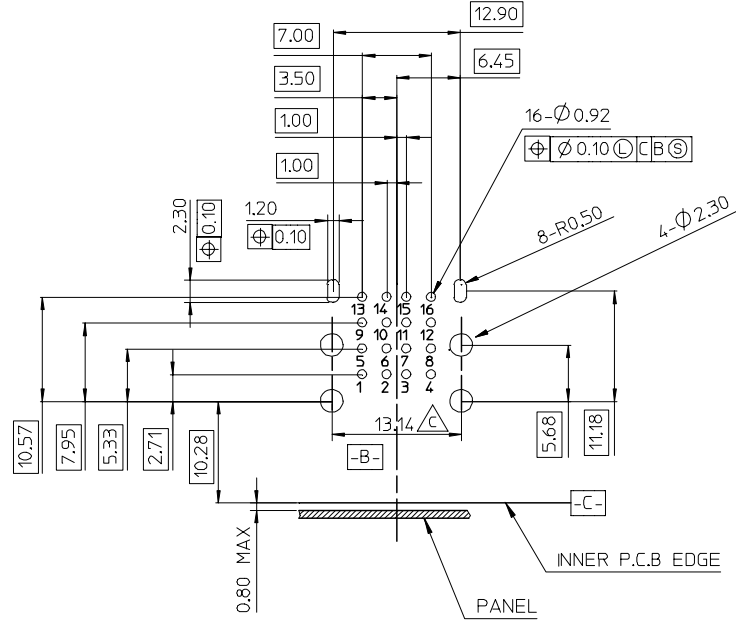

RECOMMENDED P.C.B. LAYOUT (2) (THICKNESS=1.6MM)  
(GENERAL TOLERANCE: ±0.05MM)

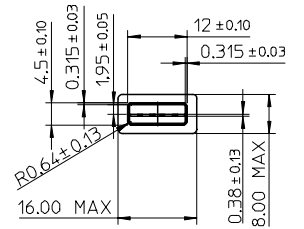
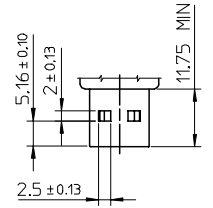

USB CABLE DRAWING

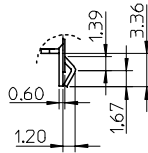

DETAIL A  
SCALE 2:1

REVISED EC NO: SH2007-0796 DRW: EKA001 CHKD: APPR: WWSCHANG	DESCRIPTION 2007/06/01 2007/06/01 2007/06/01	QUALITY SYMBOLS	GENERAL TOLERANCES (UNLESS SPECIFIED)	DIMENSION STYLE MM ONLY	SCALE 1:1	DESIGN UNITS METRIC	THIRD ANGLE PROJECTION																																
		$\nabla = 0$ $\triangle = 0$	<table border="1"> <thead> <tr> <th></th> <th>mm</th> <th>INCH</th> </tr> </thead> <tbody> <tr> <td>4 PLACES</td> <td>± ---</td> <td>± ---</td> </tr> <tr> <td>3 PLACES</td> <td>± ---</td> <td>± ---</td> </tr> <tr> <td>2 PLACES</td> <td>± 0.25</td> <td>± ---</td> </tr> <tr> <td>1 PLACE</td> <td>± 0.25</td> <td>± ---</td> </tr> <tr> <td colspan="3">ANGULAR ± 3°</td> </tr> </tbody> </table>		mm	INCH	4 PLACES	± ---	± ---	3 PLACES	± ---	± ---	2 PLACES	± 0.25	± ---	1 PLACE	± 0.25	± ---	ANGULAR ± 3°			<table border="1"> <thead> <tr> <th>DRAWN BY</th> <th>DATE</th> <th>TITLE</th> </tr> </thead> <tbody> <tr> <td>DEQUAN</td> <td>05/04/13</td> <td rowspan="2">USB 4 STACKS</td> </tr> <tr> <td>CHECKED BY</td> <td>DATE</td> </tr> <tr> <td>ERIC KAO</td> <td>05/04/13</td> <td></td> </tr> <tr> <td>APPROVED BY</td> <td>DATE</td> <td></td> </tr> <tr> <td>WWSCHANG</td> <td>05/04/13</td> <td></td> </tr> </tbody> </table>	DRAWN BY	DATE	TITLE	DEQUAN	05/04/13	USB 4 STACKS	CHECKED BY	DATE	ERIC KAO	05/04/13		APPROVED BY	DATE		WWSCHANG	05/04/13	
	mm	INCH																																					
4 PLACES	± ---	± ---																																					
3 PLACES	± ---	± ---																																					
2 PLACES	± 0.25	± ---																																					
1 PLACE	± 0.25	± ---																																					
ANGULAR ± 3°																																							
DRAWN BY	DATE	TITLE																																					
DEQUAN	05/04/13	USB 4 STACKS																																					
CHECKED BY	DATE																																						
ERIC KAO	05/04/13																																						
APPROVED BY	DATE																																						
WWSCHANG	05/04/13																																						
		DRAFT WHERE APPLICABLE MUST REMAIN WITHIN DIMENSIONS	SIZE A3	SEE TABLE	DOCUMENT NO. SD-67857-002	SHEET NO. 2 OF 2																																	