

SIGN	DATE	DESCRIPTION	APPROVER

THIS IS CAD DRAWING, DO NOT REVISE MANUALLY!!!

**Material**

- Terminal body: Brass(CuZn)
- Terminal screw: Steel Zinc plating "-" slot type
- Wire guard: Stainless steel
- Terminal housing: Thermoplastic (UL94V-0)

**Electrical UL/CSA/VDE**

- Voltage rating: 300VAC
- Current rating: 16A
- Wire range:
  - Solid wire(AWG): 14-26
  - Stranded wire(AWG): 14-26
- Torque: 2.6Lb-In
- Screw: M3
- Wire strip length: 6-7mm
- Withstanding Voltage: 1.5KV
- Operating temperature: -40°C to +115°C
- Soldering temperature: 250°C±10°C/5 Sec
- Safety Approval: 

RoHS Compliant

PART NUMBER:

**OSTTAXX0161B**

- |              |                    |
|--------------|--------------------|
| No. of Poles | COLOR              |
| 02 2 Poles   | 0: Black           |
| 03 3 Poles   | 5: Green           |
| ...          | 6: Blue (Standard) |
| 24 24 Poles  | 8: Grey            |

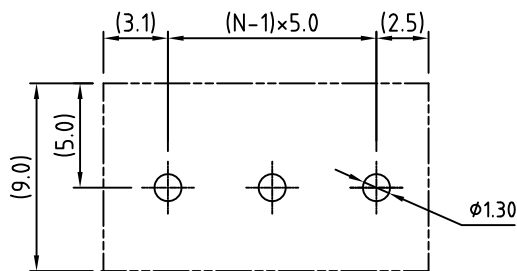
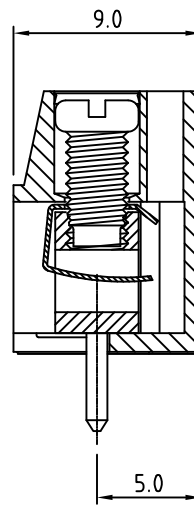
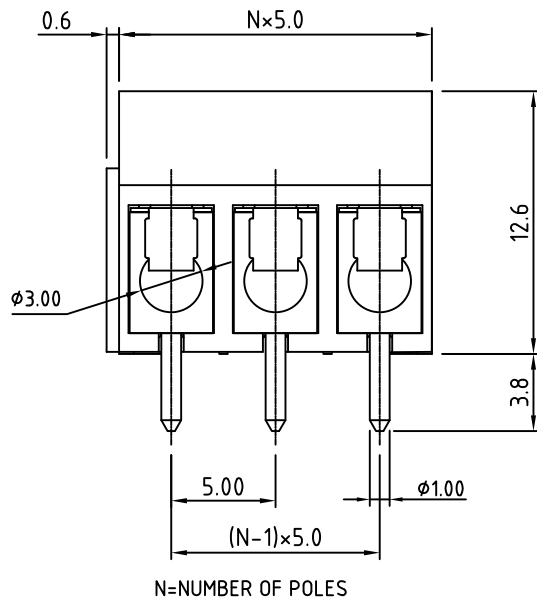
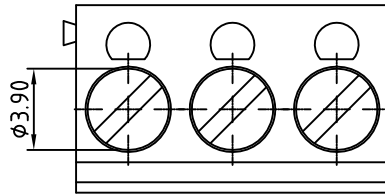

THESE DRAWINGS AND SPECIFICATIONS ARE THE PROPERTY OF ON-SHORE TECHNOLOGY, INC. AND SHALL NOT BE REPRODUCED, COPIED OR USED IN ANY MANNER WITHOUT THE PRIOR WRITTEN CONSENT OF ON-SHORE TECHNOLOGY, INC.



TITLE		OSTTA - 5.0mm series 1-Interlock			
PART NO.	OSTTAXX0161B	DWG NO.	OSTTAXX0161B.DWG		
APPROVED	CHECKED	DESIGNED	DRAWN	CUST NO.	Tolerance
	Marvin 2010.05.18	Marvin 2010.05.18	Marvin 2010.05.18		X. ±0.50 X.X ±0.30 X.XX ±0.10 X° ±1°
					UNIT: mm
				SHEET: 01/01	SCALE: NONE
				REV.: E	