

REVISIONS				
P.	LTN.	DESCRIPTION	DATE	OWN. APVD.
A		RELEASE PER ECO-10-025263	10FEB2011	CJV JTL
B		RELEASE PER ECO-16-009259	17JUN2016	PP SH
B1		REVISED PER ECN-22-166164	25JUL2022	IT SZ

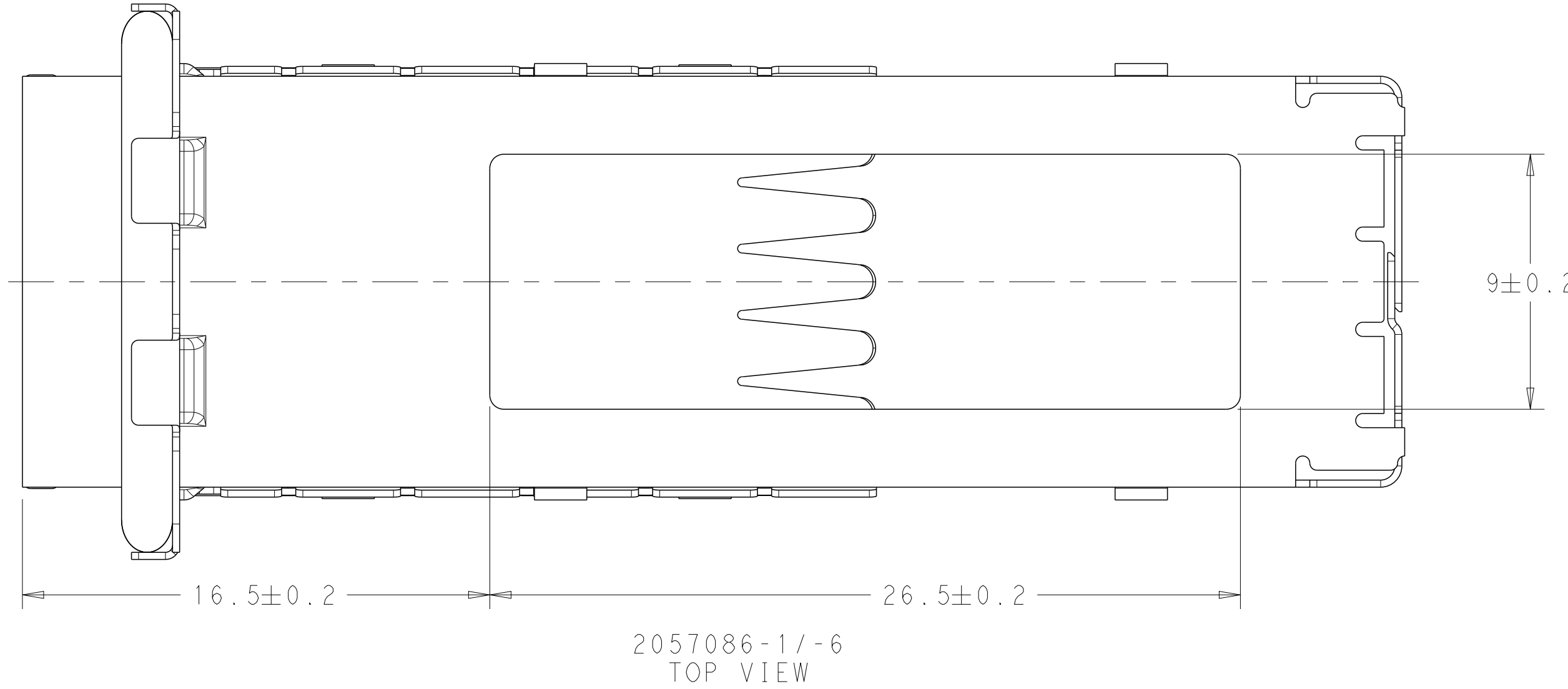

- 1 MATERIAL:
CAGE ASSEMBLY: NICKEL SILVER ALLOY, 0.25mm THK.
GASKET RETENTION PLATE: STAINLESS STEEL
EMI GASKET: PLATED FILLED SILICONE
- 2 MINIMUM PC BOARD THICKNESS:
SINGLE SIDED = 1.45mm
- 3 PADS AND VIAS CHASSIS GROUND.
- 4 DATUM AND BASIC DIMENSION ESTABLISHED BY CUSTOMER.
- 5. MATES WITH SFP MSA COMPLIANT TRANSCEIVERS.
- 6. INTERPRETATION OF DATUM REFERENCE FRAME IN ACCORDANCE WITH SECT 4.4.1.1 OF ASME Y14.5M-1994.
- 7 REFERENCE APPLICATION SPEC. 114-13120, HOLE A, FOR RECOMMENDED DRILL HOLE DIAMETER AND PLATING THICKNESS.
- 8 REFERENCE APPLICATION SPEC. 114-13120, HOLE B, FOR RECOMMENDED DRILL HOLE DIAMETER AND PLATING THICKNESS.

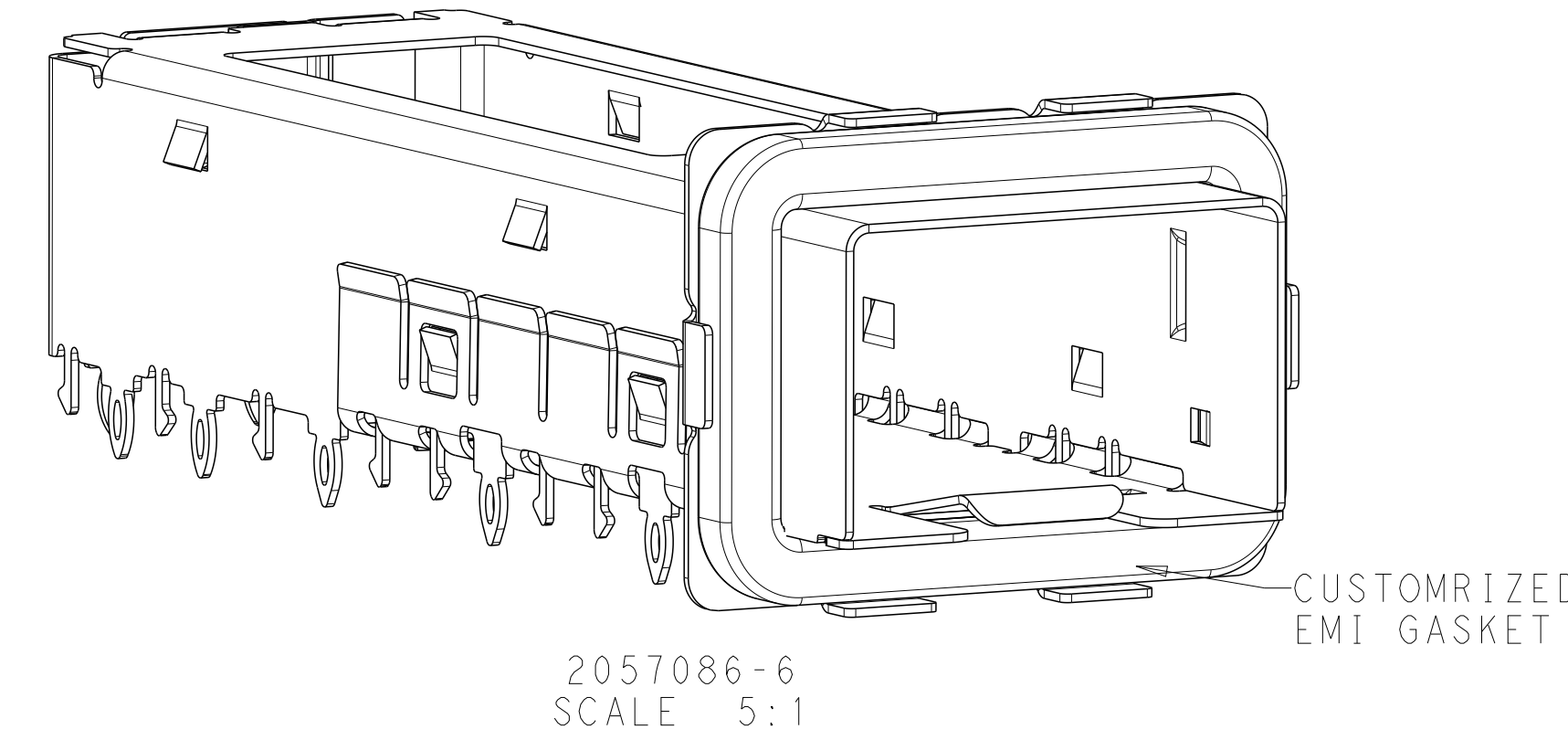
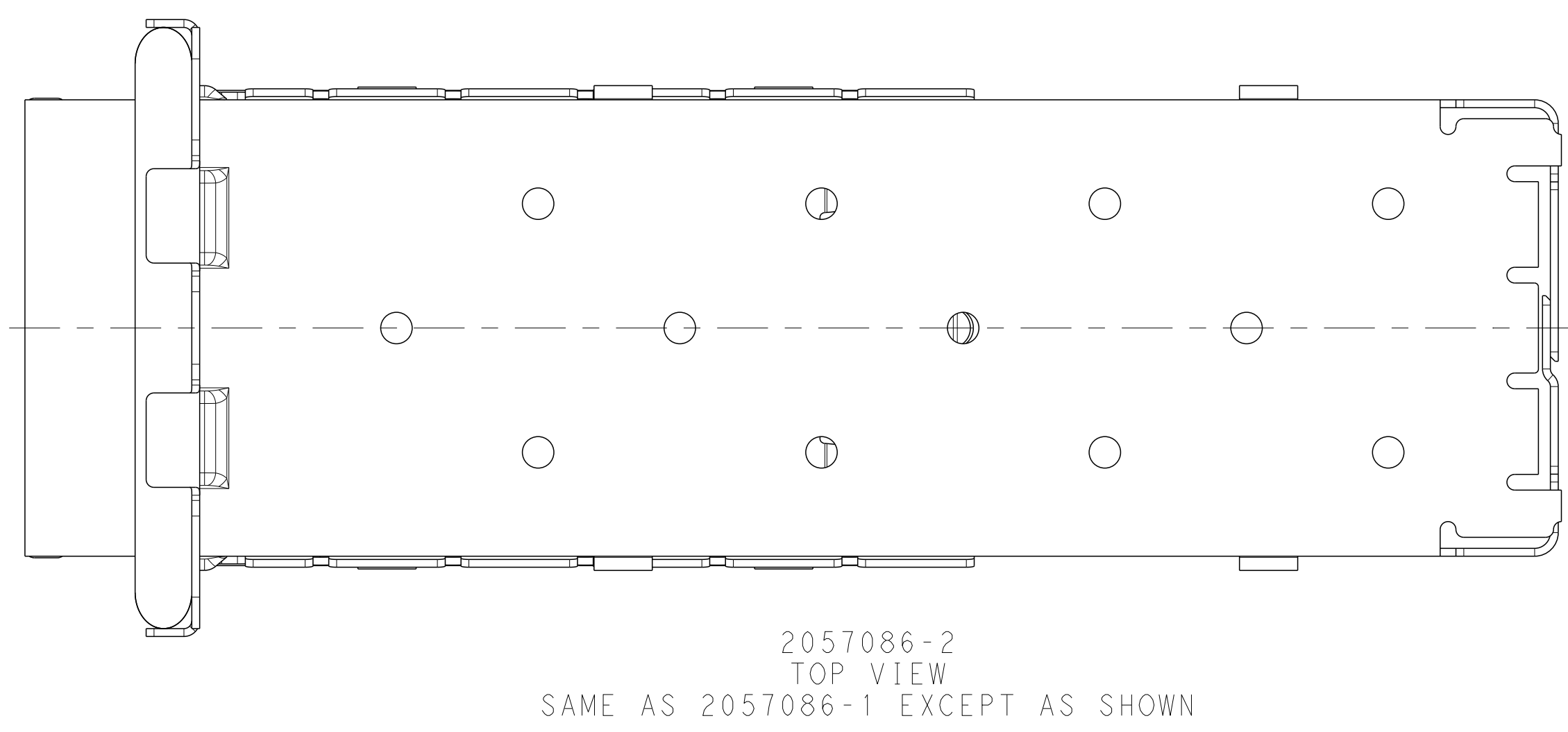
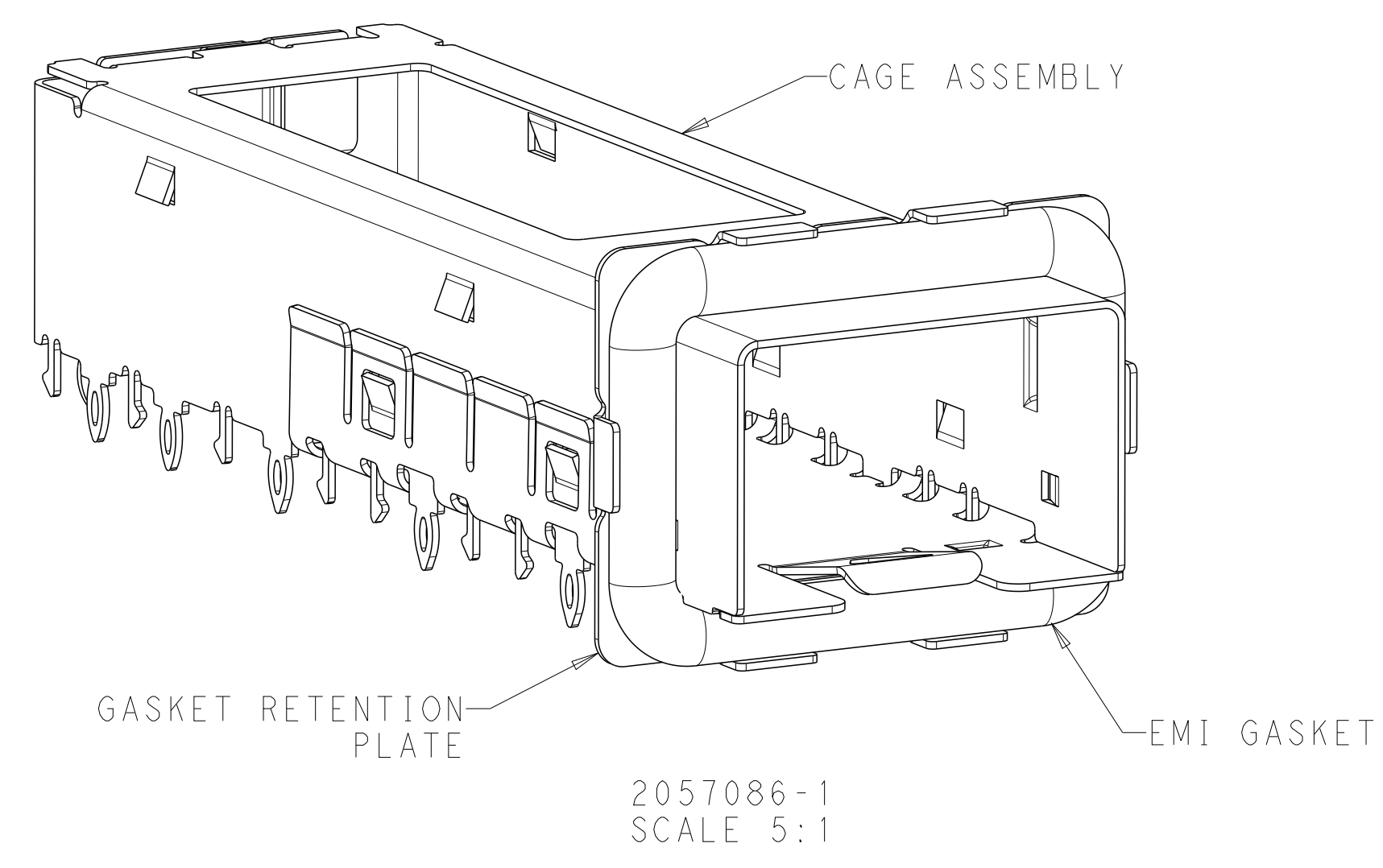
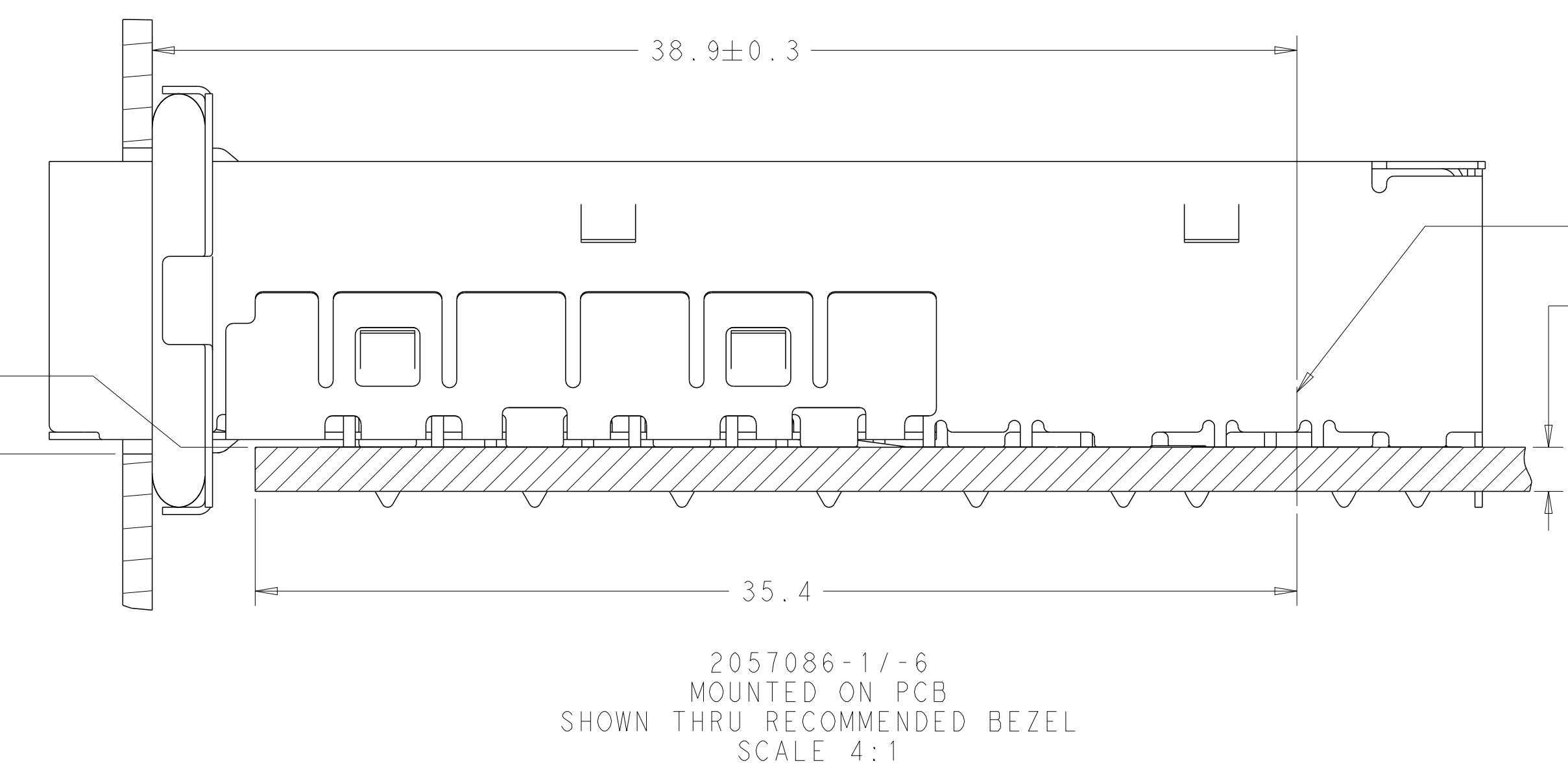
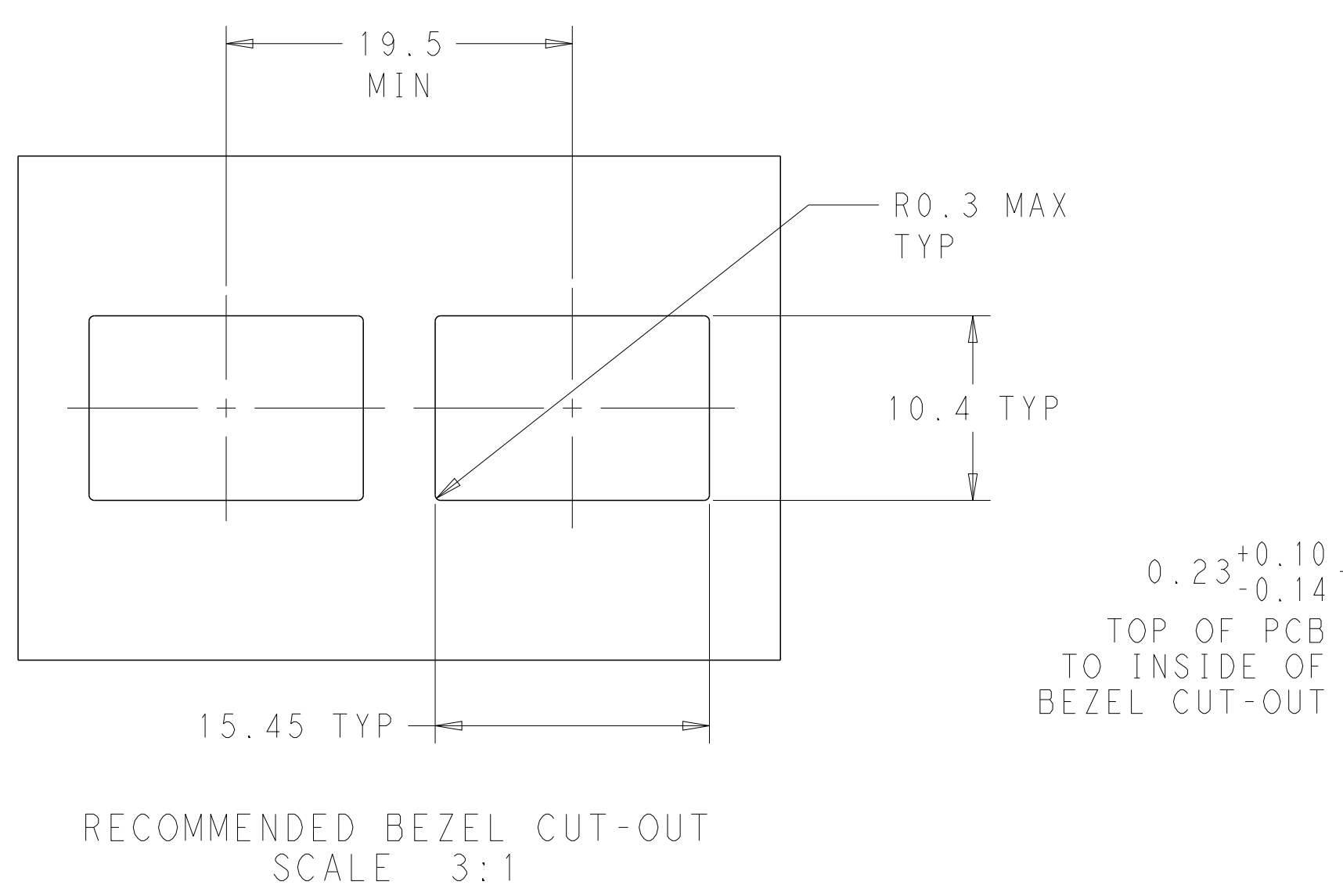
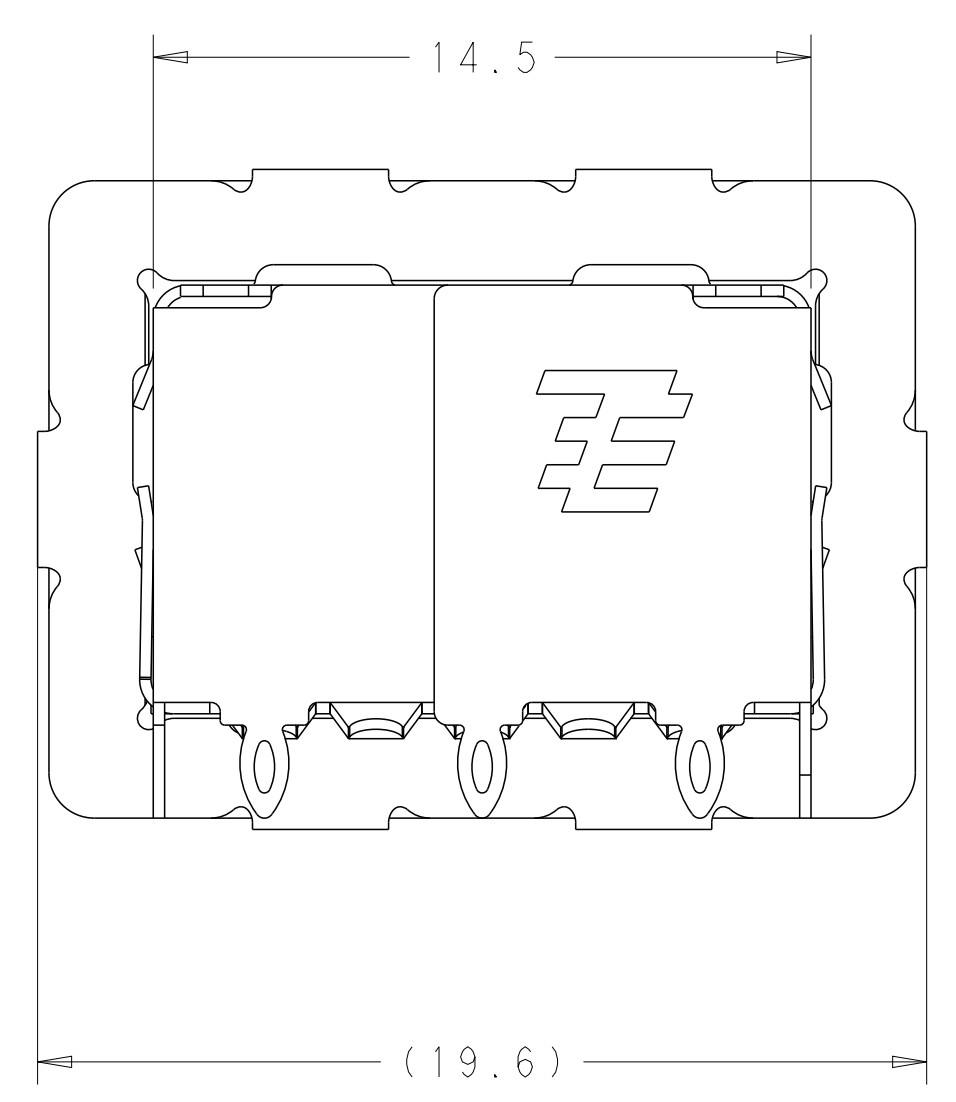
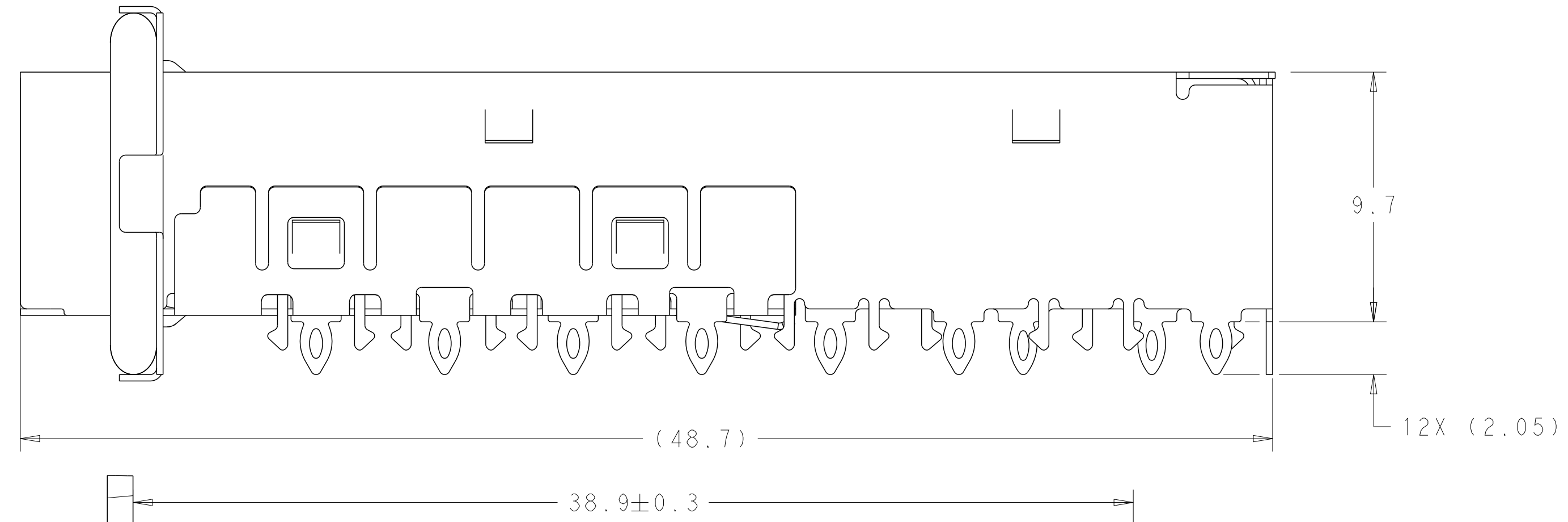
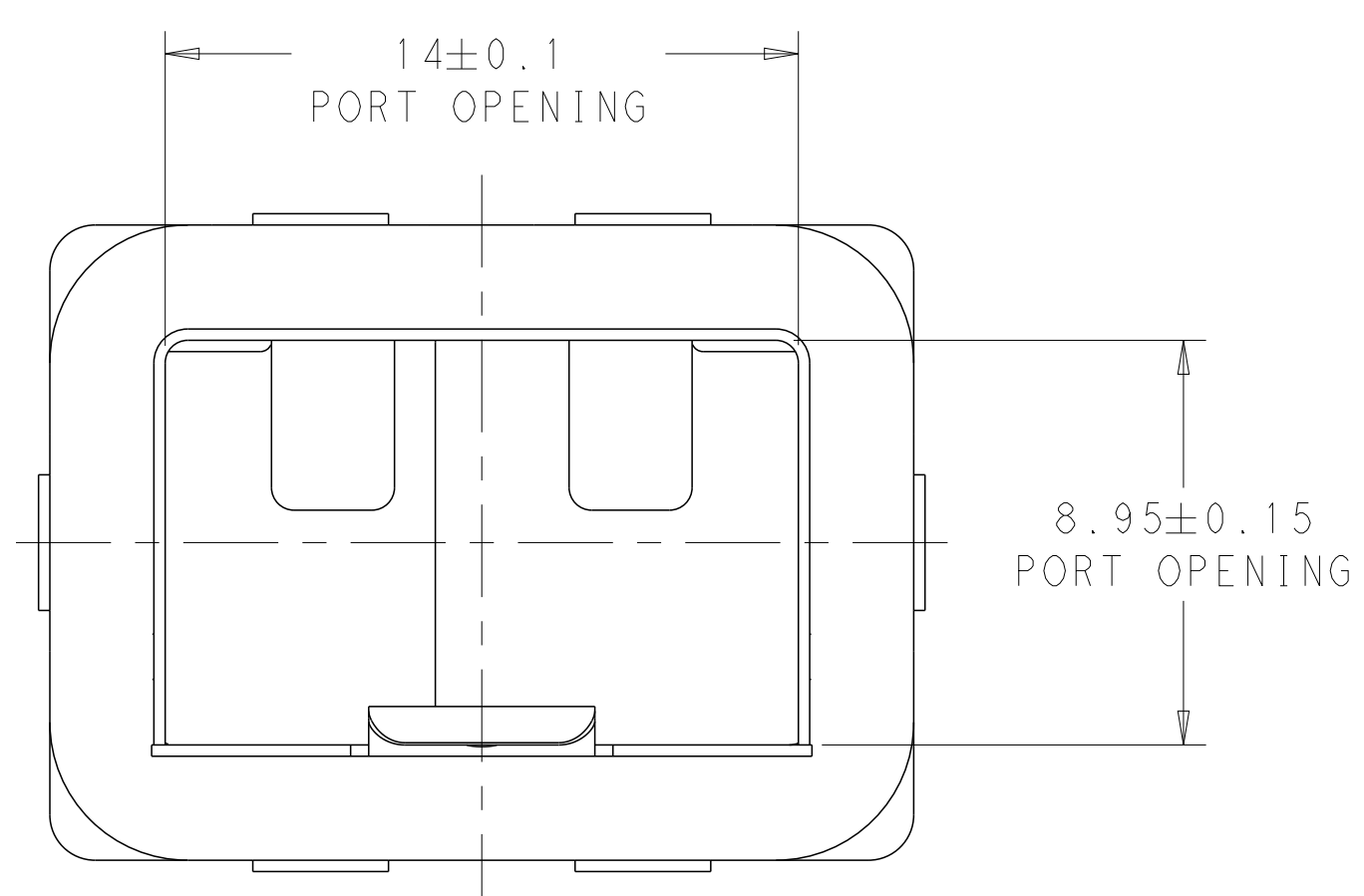

CUSTOMIZED TYPE		W/ HEATSINK OPENING	2057086-6
GENERAL TYPE		W/O HEATSINK OPENING	2057086-2
GENERAL TYPE		W/ HEATSINK OPENING	2057086-1
GASKET		DESCRIPTION	PART NUMBER
THIS DRAWING IS A CONTROLLED DOCUMENT.		OWN: Z.M. REAM 18MAR2008	TE Connectivity NAME: SFP+ ENHANCED 1X1 CAGE ASSEMBLY, PRESS-FIT, SIZE: CAGE CODE DRAWING NO: A100779 ©=2057086-1.asm RESTRICTED TO:
DIMENSIONS: mm		CHK: M.R. SCHMITT 18MAR2008	
TOLERANCES UNLESS OTHERWISE SPECIFIED:		APVD: R.H. WERTZ 18MAR2008	
0 PLC ±0.1 1 PLC ±0.1 2 PLC ±0.1 3 PLC ±0.05 4 PLC ±0.05 ANGLES ±0.05		PRODUCT SPEC: 108-2364 APPLICATION SPEC: 114-13120 WEIGHT: - CUSTOMER DRAWING	
MATERIAL:		SCALE: 6:1 SHEET 1 OF 2 REV: B1	

REVISIONS				
P.	LTN.	DESCRIPTION	DATE	APVD.
-	-	SEE SHEET 1	-	-

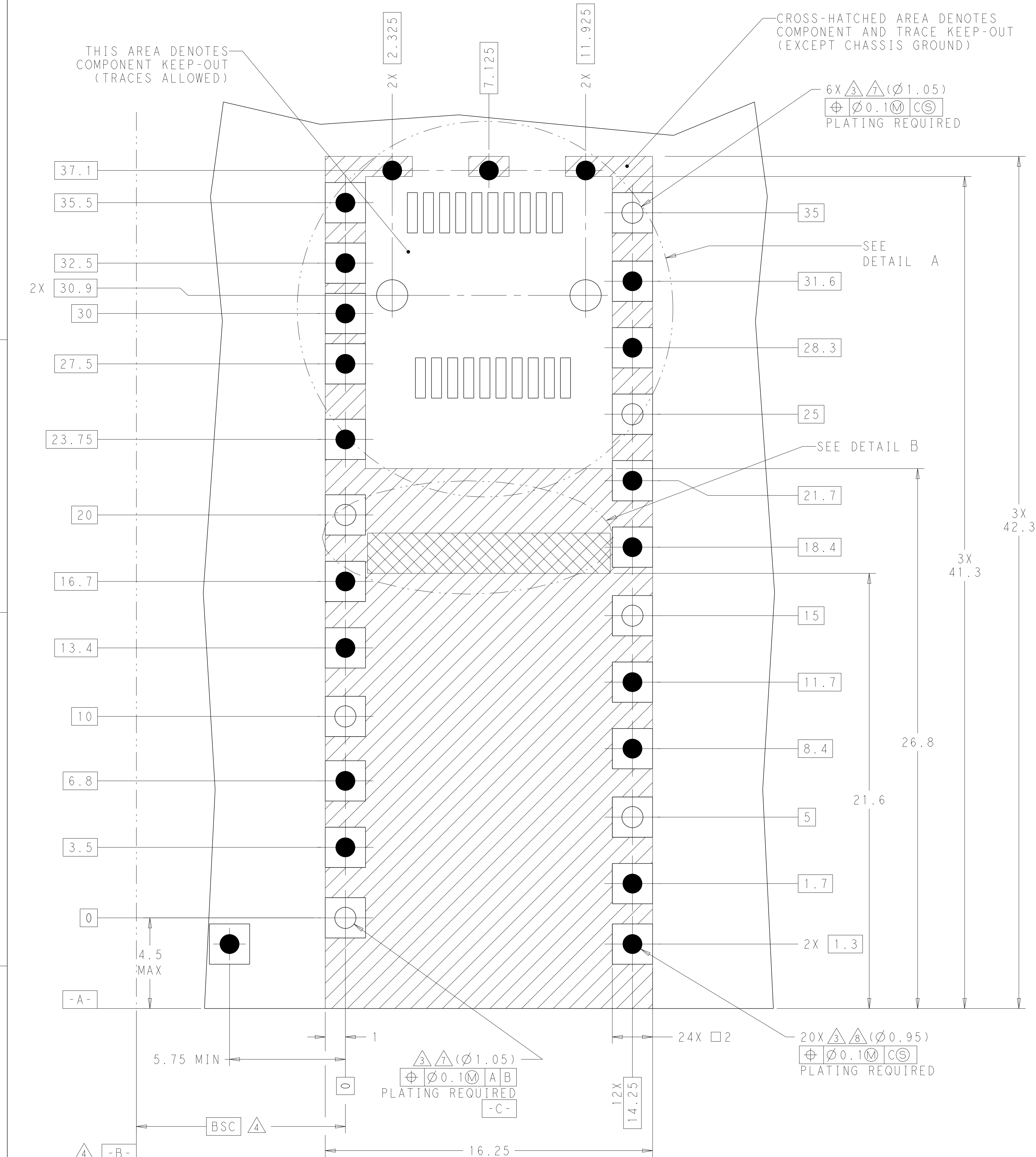

RECOMMENDED PC BOARD CONFIGURATION WITH KEEP-OUT AREAS SCALE 9:1

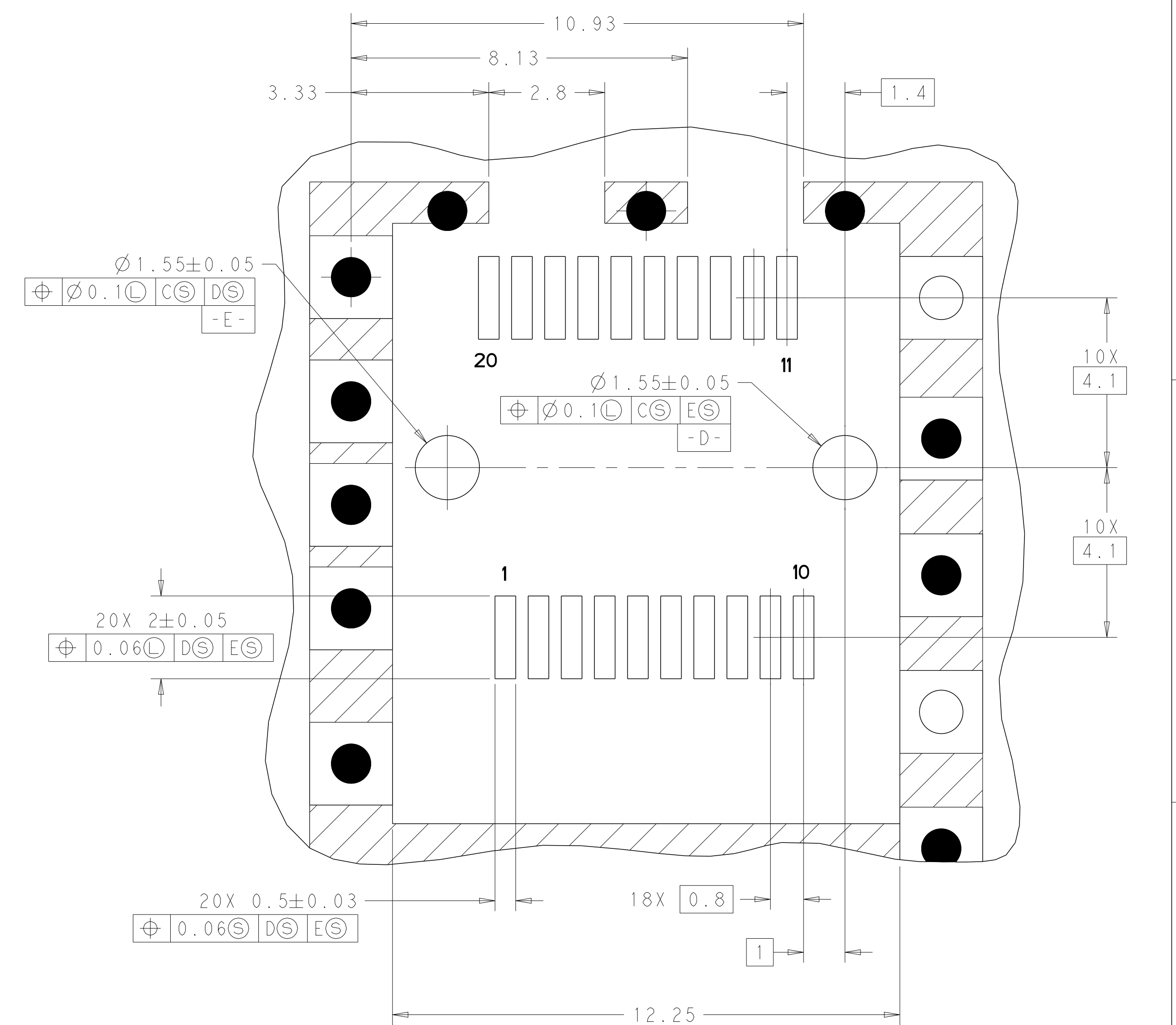

DETAIL A
 RECOMMENDED PT CONNECTOR LAYOUT
 SCALE 12:1

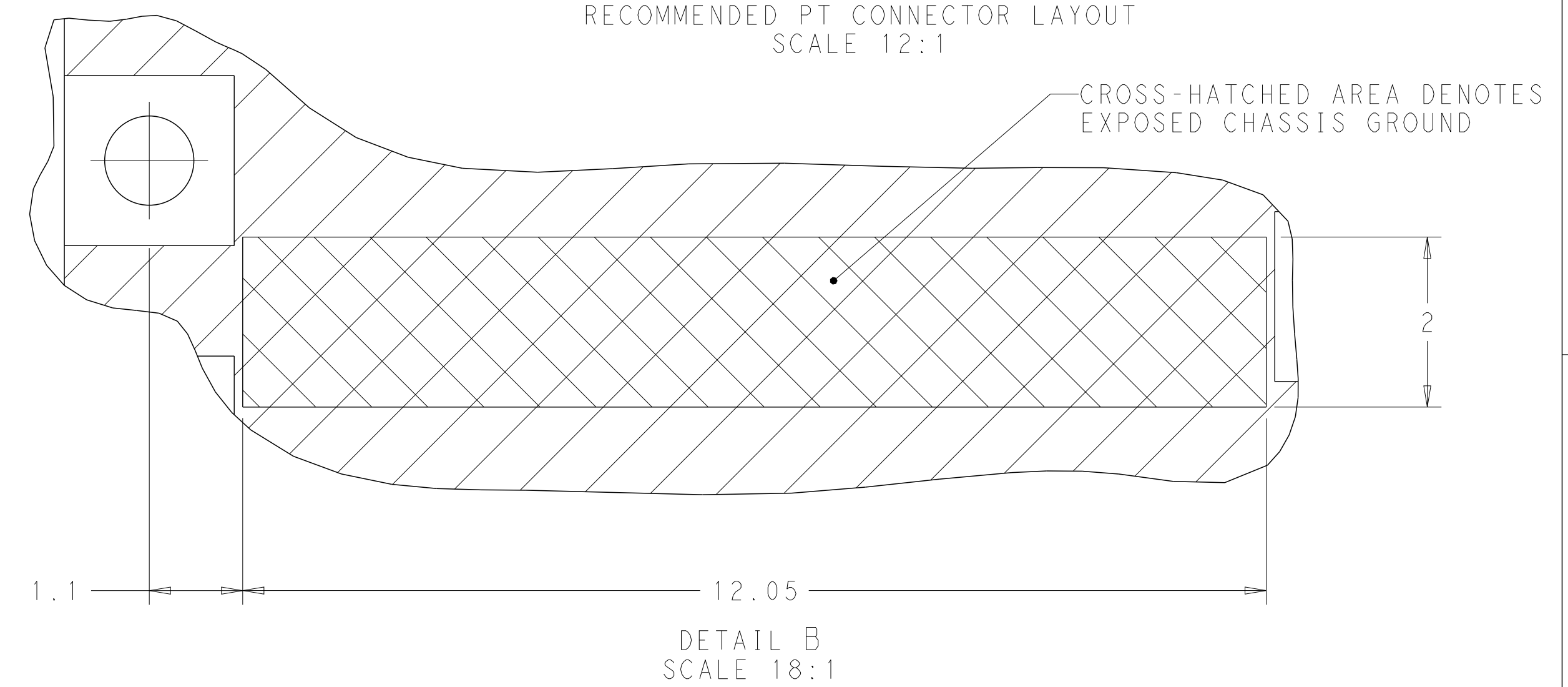

THIS DRAWING IS A CONTROLLED DOCUMENT.		OWN: Z.M. REAM 18MAR2008	TE Connectivity
DIMENSIONS: mm		CHK: M.B. SCHMITT 18MAR2008	
TOLERANCES UNLESS OTHERWISE SPECIFIED:		APVD: B.H. WERTZ 18MAR2008	NAME: SFP+ ENHANCED 1X1 CAGE ASSEMBLY, PRESS-FIT,
0 PLC ±0.1	1 PLC ±0.1	PRODUCT SPEC	SIZE: CAGE CODE DRAWING NO
2 PLC ±0.1	3 PLC ±0.05	108-2364	RESTRICTED TO
4 PLC ±0.05	ANGLES ±0.05	APPLICATION SPEC	A100779
MATERIAL:	FINISH:	114-13120	SCALE 6:1 SHEET 2 OF 2 REV B1
CUSTOMER DRAWING		WEIGHT:	