

NB3N853501E

3.3 V LVTTTL/LVCMOS 2:1 MUX to 4 LVPECL Differential Clock Fanout Buffer Outputs with Clock Enable and Clock Select



ON Semiconductor®

<http://onsemi.com>

Description

The NB3N853501E is a pure 3.3 V supply 2:1:4 clock distribution fanout buffer. Input MUX selects one of two LVCMOS/LVTTTL CLK lines by the CLK_SEL pin (HIGH for CLK1, LOW for CLK0) using LVCMOS/LVTTTL levels. Outputs are LVPECL levels and are synchronously enabled by CLK_EN using LVCMOS/LVTTTL levels (HIGH to enable outputs, LOW to disable output).

Features

- Four differential LVPECL Outputs
- Two Selectable LVCMOS/LVTTTL CLOCK Inputs
- Up to 266 MHz Clock Operation
- Output to Output Skew: 30 ps (Max.)
- Device to Device Skew 250 ps (Max.)
- Propagation Delay 2.0 ns (Max.)
- Operating range: $V_{CC} = 3.3 \pm 5\% V$ (3.135 to 3.465 V)
- Additive Phase Jitter, RMS: 62 fs (Typ)
- Synchronous Clock Enable Control
- Industrial Temp. Range (-40°C to 85°C)
- Pb-Free TSSOP20 Package
- These are Pb-Free Devices

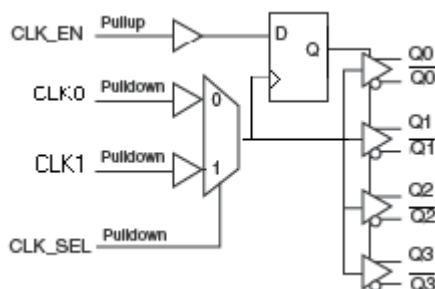
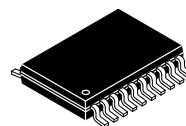
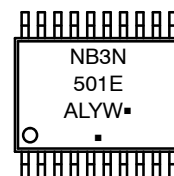

Figure 1. Simplified Logic Diagram

MARKING DIAGRAM



TSSOP-20
DT SUFFIX
CASE 948E



A = Assembly Location
L = Wafer Lot
Y = Year
W = Work Week
▪ = Pb-Free Package

(Note: Microdot may be in either location)

ORDERING INFORMATION

See detailed ordering and shipping information in the package dimensions section on page 7 of this data sheet.

NB3N853501E

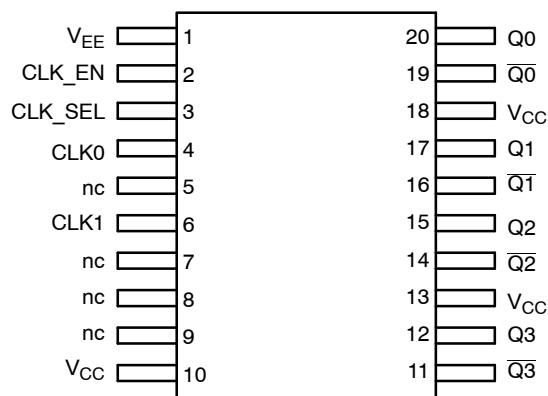

Figure 2. Pinout Diagram (Top View)

Table 1. PIN DESCRIPTION

Number	Name	I/O	Open Default	Description
1	V _{EE}			Negative (Ground) Power Supply pin must be externally connected to power supply to guarantee proper operation.
2	CLK_EN	LVC MOS / LV TTL	Pullup	Synchronized Clock Enable when HIGH. When LOW, outputs are disabled (Q _x HIGH, \overline{Q}_x LOW)
3	CLK_SEL	LVC MOS / LV TTL	Pulldown	Clock Input Select (HIGH selects CLK1, LOW selects CLK0 input)
4	CLK0	LVC MOS / LV TTL	Pulldown	Clock 0 Input. Float open when unused.
5, 6, 8, 9	nc			No Connect
6	CLK1	LVC MOS / LV TTL	Pulldown	Clock 1 Input. Float open when unused.
10, 13, 18	V _{CC}			Positive Power Supply pins must be externally connected to power supply to guarantee proper operation.
11, 14, 16, 19	$\overline{Q}[3:0]$	LVPECL		Invert Differential Outputs
12, 15, 16, 20	Q[3:0]	LVPECL		True Differential Outputs

Table 2. FUNCTIONS

Inputs			Outputs		
CLK_EN	CLK_SEL	Input Function	Output Function	Q _x	\overline{Q}_x
0	0	CLK0 input selected	Disabled	LOW	HIGH
0	1	CLK1 Input Selected	Disabled	LOW	HIGH
1	0	CLK0 input selected	Enabled	CLK0	Invert of CLK1
1	1	CLK1 Input Selected	Enabled	CLK1	Invert of CLK1

1. After CLK_EN switches, the clock outputs are disabled or enabled following a rising and falling input clock edge as show in Figure 3.

NB3N853501E

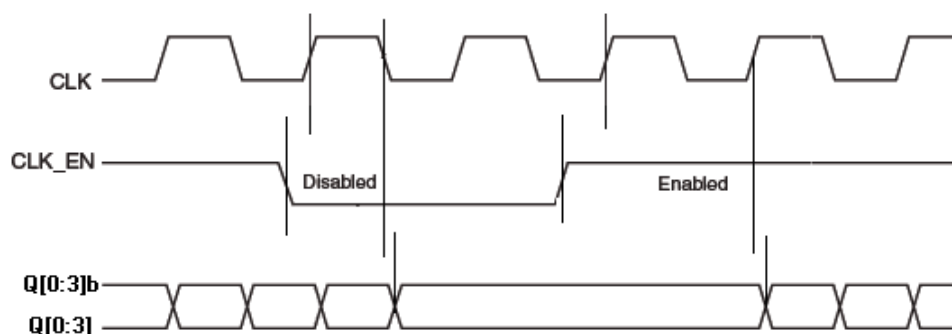

Figure 3. CLK_EN TIMING DIAGRAM

Table 3. ATTRIBUTES (Note 2)

Characteristics	Value
Internal Input Pullup Resistor	50 kΩ
Internal Input Pulldown Resistor	50 kΩ
ESD Protection	Human Body Model Machine Model
	> 2 kV > 200 V
Moisture Sensitivity, Indefinite Time Out of Drypack (Note 2)	Level 1
Flammability Rating Oxygen Index	UL 94 V-0 @ 0.125 in 28 to 34
Transistor Count	317 Devices
Meets or exceeds JEDEC Spec EIA/JESD78 IC Latchup Test	

2. For additional information, see Application Note AND8003/D.

Table 4. MAXIMUM RATINGS (Note 3)

Symbol	Parameter	Condition 1	Condition 2	Rating	Unit
V_{CC}	Supply Voltage			4.6	V
V_{in}	Input Voltage			$-0.5 \leq V_I \leq V_{CC} + 0.5$	V
C_{in}	Input Capacitance			4	pF
I_{out}	Output Current	Continuous Surge		50 100	mA
T_A	Operating Temperature Range, Industrial			-40 to \leq +85	°C
T_{stg}	Storage Temperature Range			-65 to +150	°C
θ_{JA}	Thermal Resistance (Junction-to-Ambient)	0 lfpm 500 lfpm	TSSOP-20	140 50	°C/W
θ_{JA}	Thermal Resistance (Junction-to-Ambient)	0 lfpm	Single-Layer PCB (700 mm ² , 2 oz)	128	°C/W
		200 lfpm	Multi-Layer PCB (700 mm ² , 2 oz)	94	
θ_{JC}	Thermal Resistance (Junction-to-Case)	(Note 4)	TSSOP-20	23 to 41	°C/W
T_{sol}	Wave Solder			265	°C

Stresses exceeding Maximum Ratings may damage the device. Maximum Ratings are stress ratings only. Functional operation above the Recommended Operating Conditions is not implied. Extended exposure to stresses above the Recommended Operating Conditions may affect device reliability.

3. Maximum ratings applied to the device are individual stress limit values (not normal operating conditions) and not valid simultaneously.

If stress limits are exceeded device functional operation is not implied, damage may occur and reliability may be affected.

4. JEDEC standard multilayer board – 2S2P (2 signal, 2 power).

NB3N853501E

Table 5. DC CHARACTERISTICS $V_{CC} = 3.3 \pm 5\% \text{ V}$ (3.135 to 3.465 V), $GND = 0 \text{ V}$, $T_A = -40^\circ\text{C}$ to $+85^\circ\text{C}$ (Note 5)

Symbol	Characteristic	Min	Typ	Max	Unit
I_{EE}	Power Supply Current			50	mA
V_{IH}	Input HIGH Voltage	2		$V_{CC} + 0.3$	V
V_{IL}	Input LOW Voltage CLK0 CLK1 CLK_EN CLK_SEL	-0.3 -0.3		1.3 0.8	V
I_{IH}	Input High Current ($V_{CC} = V_{in} = 3.456 \text{ V}$) CLKx, CLK_SEL CLK_EN			150 5	μA
I_{IL}	Input LOW Current ($V_{CC} = 3.456 \text{ V}$; $V_{in} = GND$) CLKx, CLK_SEL CLK_EN	-5 -150			μA
V_{OH}	Output HIGH Voltage	$V_{CC} - 1.4$		$V_{CC} - 0.9$	V
V_{OL}	Output LOW Voltage	$V_{CC} - 2.0$		$V_{CC} - 1.7$	V
V_{OUT_SWING}	Output Voltage Swing (peak-to-peak)	0.6		1.0	V

NOTE: Device will meet the specifications after thermal equilibrium has been established when mounted in a test socket or printed circuit board with maintained transverse airflow greater than 500 lpm. Electrical parameters are guaranteed only over the declared operating temperature range. Functional operation of the device exceeding these conditions is not implied. Device specification limit values are applied individually under normal operating conditions and not valid simultaneously.

5. Outputs terminated 50 Ω to $V_{CC} - 2.0 \text{ V}$, see Figure 4. Input levels of 0.8 V and 2.4 V unless stated otherwise.

NB3N853501E

Table 6. AC CHARACTERISTICS $V_{CC} = 3.3 \pm 5\% \text{ V}$ (3.135 to 3.465 V), $GND = 0 \text{ V}$, $T_A = -40^\circ\text{C}$ to $+85^\circ\text{C}$ (Note 6)

Symbol	Characteristic	Min	Typ	Max	Unit
F_{MAX}	Maximum Operating Frequency	0		266	MHz
t_{PD}	Propagation Delay	0.9		2.0	ns
$t_{SKEW_{DC}}$	Duty Cycle Skew same path similar conditions at 50 MHz	48	50	52	%
$t_{SKEW_{O-O}}$	Output to Output Skew Within A Device			30	ps
$t_{SKEW_{D-D}}$	Device-to-Device Skew similar path and conditions			250	ps
t_{JIT}	Additive Phase Noise Jitter (RMS) @ 155.52 MHz (Integrated from 12 kHz to 20 MHz) See Figure 6.		0.062		ps
t_r/t_f	Output rise and fall times @ 266 MHz (20% and 80% points)	240		700	ps

NOTE: Device will meet the specifications after thermal equilibrium has been established when mounted in a test socket or printed circuit board with maintained transverse airflow greater than 500 lfm. Electrical parameters are guaranteed only over the declared operating temperature range. Functional operation of the device exceeding these conditions is not implied. Device specification limit values are applied individually under normal operating conditions and not valid simultaneously.

6. Outputs terminated 50Ω to $V_{CC} - 2.0 \text{ V}$, see Figure 4. Input levels of 0.8 V and 2.4 V unless stated otherwise. Measured from Input Midpoint ($V_{DD}/2$) to differential Output crosspoints, see Figure 5.

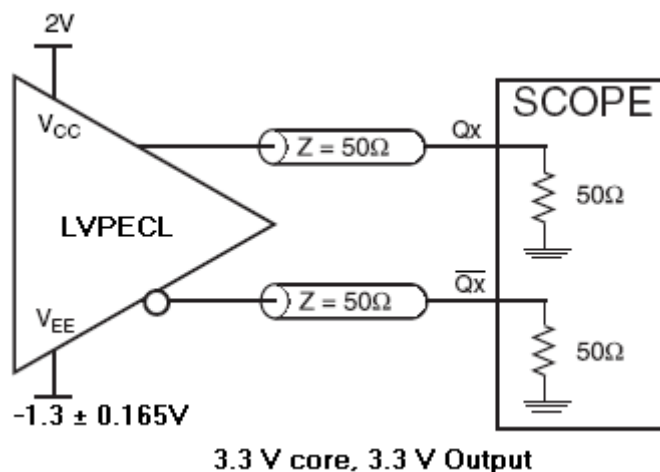
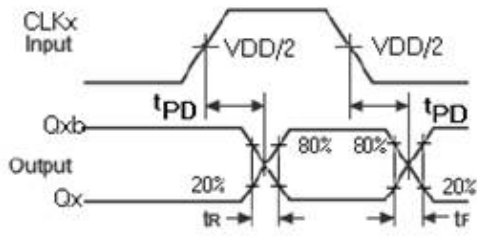
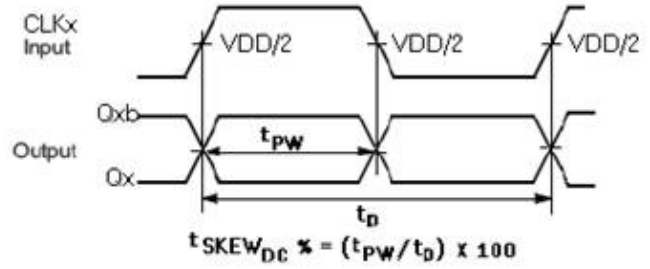

Figure 4. Typical Test Setup and Termination for Evaluation. The V_{CC} of 2.0 V and V_{EE} of $-1.3 \pm 0.165 \text{ V}$ Split supply allows a direct connection to an oscilloscope 50Ω impedance input module. Also reference AND8020.

Propagation Delay



Duty Cycle Skew - tSKEWDC



Output to Output Skew

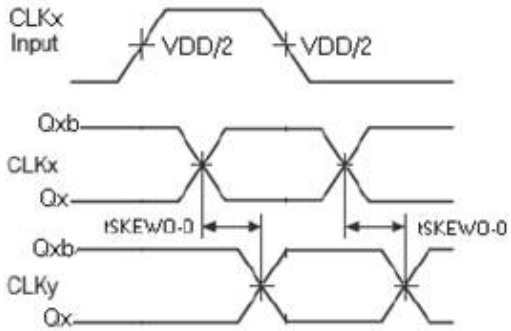

Device to Device Skew

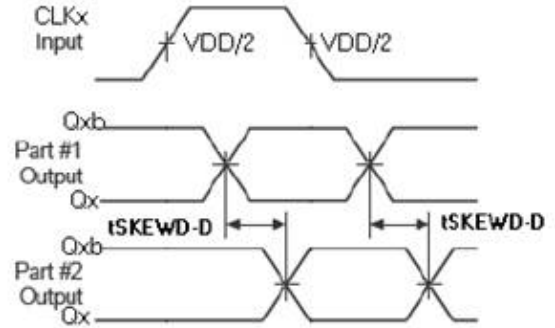

Figure 5. AC Measurement Reference

NB3N853501E

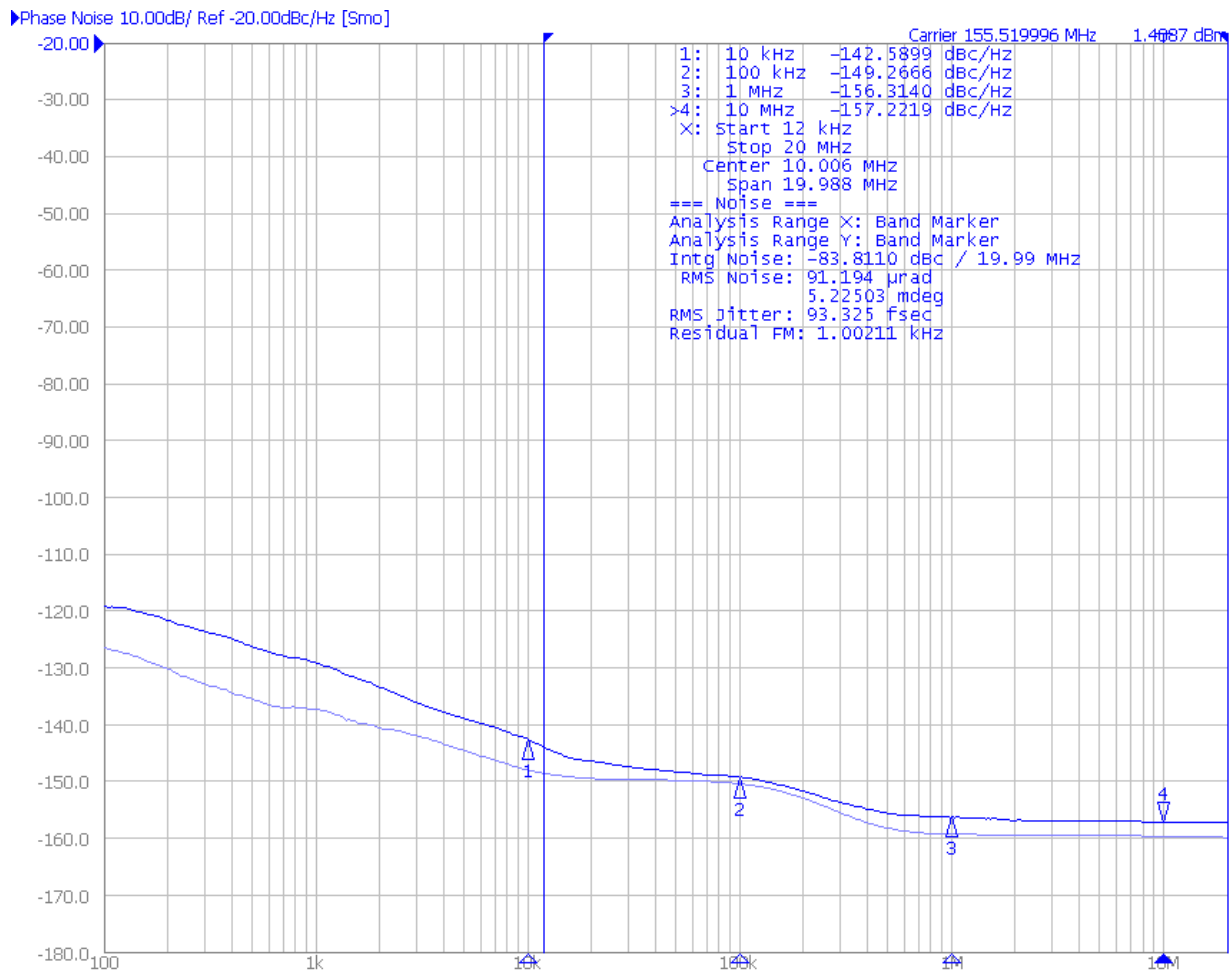

Figure 6. For 155.52 MHz carrier, the NB3N853501E Additive Phase Noise (dBc/Hz) versus SSB Offset Frequency (Hz) Integrated Jitter from 12 kHz to 20 MHz (Upper Heavy Line) is 93.3 fs RMS. The E8663B Source Generator Additive Phase Noise (Lower Light Line) is 70.1 fs RMS. Where $t_{JIT} = \sqrt{(t_{JIToutput})^2 - (t_{JITinput})^2} = 61.6$ fs

ORDERING INFORMATION

Device	Package	Shipping†
NB3N853501EDTG	TSSOP-20 (Pb-Free)	75 Units / Rail
NB3N853501EDTR2G	TSSOP-20 (Pb-Free)	2500 / Tape & Reel

†For information on tape and reel specifications, including part orientation and tape sizes, please refer to our Tape and Reel Packaging Specifications Brochure, BRD8011/D.

MECHANICAL CASE OUTLINE

PACKAGE DIMENSIONS

ON Semiconductor®

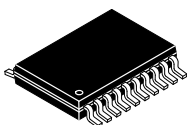

TSSOP-20 WB
CASE 948E
ISSUE D

DATE 17 FEB 2016

SCALE 2:1

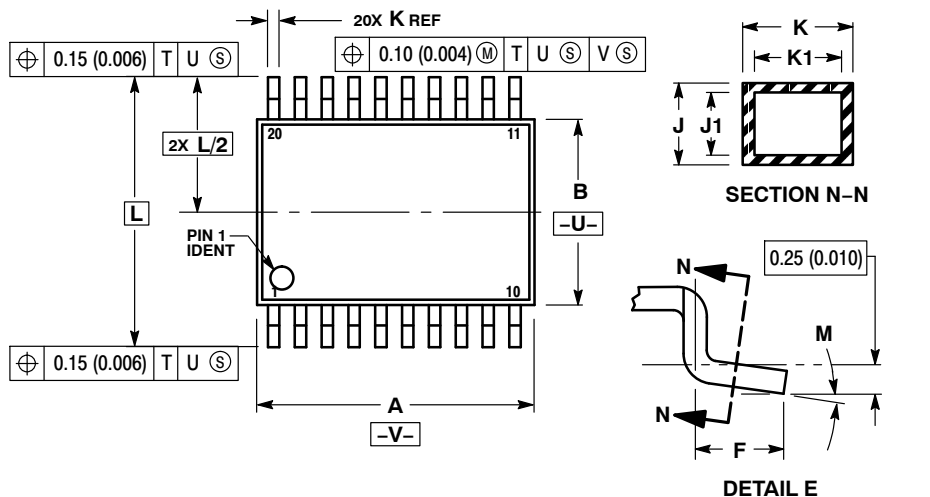

- NOTES:
1. DIMENSIONING AND TOLERANCING PER ANSI Y14.5M, 1982.
 2. CONTROLLING DIMENSION: MILLIMETER.
 3. DIMENSION A DOES NOT INCLUDE MOLD FLASH, PROTRUSIONS OR GATE BURRS. MOLD FLASH OR GATE BURRS SHALL NOT EXCEED 0.15 (0.006) PER SIDE.
 4. DIMENSION B DOES NOT INCLUDE INTERLEAD FLASH OR PROTRUSION. INTERLEAD FLASH OR PROTRUSION SHALL NOT EXCEED 0.25 (0.010) PER SIDE.
 5. DIMENSION K DOES NOT INCLUDE DAMBAR PROTRUSION. ALLOWABLE DAMBAR PROTRUSION SHALL BE 0.08 (0.003) TOTAL IN EXCESS OF THE K DIMENSION AT MAXIMUM MATERIAL CONDITION.
 6. TERMINAL NUMBERS ARE SHOWN FOR REFERENCE ONLY.
 7. DIMENSION A AND B ARE TO BE DETERMINED AT DATUM PLANE -W-.

DIM	MILLIMETERS		INCHES	
	MIN	MAX	MIN	MAX
A	6.40	6.60	0.252	0.260
B	4.30	4.50	0.169	0.177
C	---	1.20	---	0.047
D	0.05	0.15	0.002	0.006
F	0.50	0.75	0.020	0.030
G	0.65 BSC		0.026 BSC	
H	0.27	0.37	0.011	0.015
J	0.09	0.20	0.004	0.008
J1	0.09	0.16	0.004	0.006
K	0.19	0.30	0.007	0.012
K1	0.19	0.25	0.007	0.010
L	6.40 BSC		0.252 BSC	
M	0°	8°	0°	8°

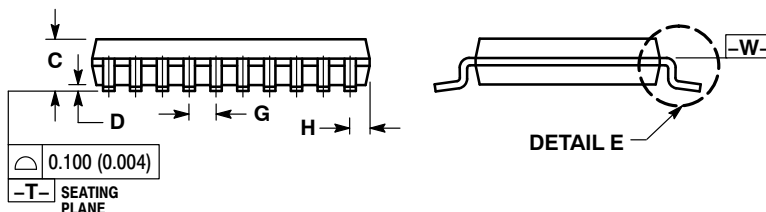

SOLDERING FOOTPRINT

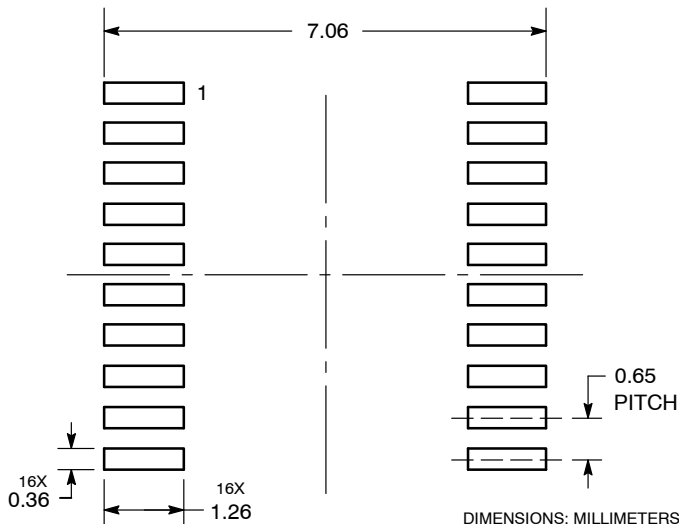

GENERIC MARKING DIAGRAM*

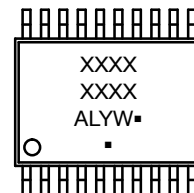

- A = Assembly Location
- L = Wafer Lot
- Y = Year
- W = Work Week
- = Pb-Free Package

(Note: Microdot may be in either location)

*This information is generic. Please refer to device data sheet for actual part marking. Pb-Free indicator, "G" or microdot "▪", may or may not be present.

DOCUMENT NUMBER:	98ASH70169A	Electronic versions are uncontrolled except when accessed directly from the Document Repository. Printed versions are uncontrolled except when stamped "CONTROLLED COPY" in red.
DESCRIPTION:	TSSOP-20 WB	PAGE 1 OF 1

ON Semiconductor and ON are trademarks of Semiconductor Components Industries, LLC dba ON Semiconductor or its subsidiaries in the United States and/or other countries. ON Semiconductor reserves the right to make changes without further notice to any products herein. ON Semiconductor makes no warranty, representation or guarantee regarding the suitability of its products for any particular purpose, nor does ON Semiconductor assume any liability arising out of the application or use of any product or circuit, and specifically disclaims any and all liability, including without limitation special, consequential or incidental damages. ON Semiconductor does not convey any license under its patent rights nor the rights of others.

onsemi, **Onsemi**, and other names, marks, and brands are registered and/or common law trademarks of Semiconductor Components Industries, LLC dba "**onsemi**" or its affiliates and/or subsidiaries in the United States and/or other countries. **onsemi** owns the rights to a number of patents, trademarks, copyrights, trade secrets, and other intellectual property. A listing of **onsemi**'s product/patent coverage may be accessed at www.onsemi.com/site/pdf/Patent-Marking.pdf. **onsemi** reserves the right to make changes at any time to any products or information herein, without notice. The information herein is provided "as-is" and **onsemi** makes no warranty, representation or guarantee regarding the accuracy of the information, product features, availability, functionality, or suitability of its products for any particular purpose, nor does **onsemi** assume any liability arising out of the application or use of any product or circuit, and specifically disclaims any and all liability, including without limitation special, consequential or incidental damages. Buyer is responsible for its products and applications using **onsemi** products, including compliance with all laws, regulations and safety requirements or standards, regardless of any support or applications information provided by **onsemi**. "Typical" parameters which may be provided in **onsemi** data sheets and/or specifications can and do vary in different applications and actual performance may vary over time. All operating parameters, including "Typicals" must be validated for each customer application by customer's technical experts. **onsemi** does not convey any license under any of its intellectual property rights nor the rights of others. **onsemi** products are not designed, intended, or authorized for use as a critical component in life support systems or any FDA Class 3 medical devices or medical devices with a same or similar classification in a foreign jurisdiction or any devices intended for implantation in the human body. Should Buyer purchase or use **onsemi** products for any such unintended or unauthorized application, Buyer shall indemnify and hold **onsemi** and its officers, employees, subsidiaries, affiliates, and distributors harmless against all claims, costs, damages, and expenses, and reasonable attorney fees arising out of, directly or indirectly, any claim of personal injury or death associated with such unintended or unauthorized use, even if such claim alleges that **onsemi** was negligent regarding the design or manufacture of the part. **onsemi** is an Equal Opportunity/Affirmative Action Employer. This literature is subject to all applicable copyright laws and is not for resale in any manner.

ADDITIONAL INFORMATION

TECHNICAL PUBLICATIONS:

Technical Library: www.onsemi.com/design/resources/technical-documentation
onsemi Website: www.onsemi.com

ONLINE SUPPORT: www.onsemi.com/support

For additional information, please contact your local Sales Representative at www.onsemi.com/support/sales