



LEOPARD FAMILY



Optional Large 0.8" Green and Red LED Display      Optional Green LED Display      Optional Custom Faceplate

## DL-40PSF-PROCESS

**Leopard Panel Meter  
4 Digit 0.56" or 0.8" LEDs  
in a 1/8 DIN CASE**

**Built-in Programmable Scale Factor  
No Input required to calibrate**

A powerful smart 4-20mA/0-10V process meter relay with isolated 4-20 mA output retransmission capability for measurement and control applications

### General Features

- Optional isolated 16 bit analog output. User or factory scalable to 4 to 20 mA, 0 to 20 mA or 0 to 10 V across any desired digital span from  $\pm$  one count to the full scale range of -1999 to 9999 (12000 counts).
- Auto-sensing AC/DC power supply. For voltages between **85-265 V AC / 95-300 V DC (PS1)** or 15-48 V AC / 10-72 V DC (PS2).
- 24 V DC excitation is available to power external transmitters. (order IP02)
- Standard red or optional green or super bright red 4-digit LED with display range -1999 to 9999 (12000 counts).
- Red or green 0.8" LED large display option
- Four annunciator LEDs provide front panel alarm status indication for up to four setpoints.
- Two 9 Amp Form C and two 4 Amp Form A relays, or optionally four 5 Amp Form A relays are available.
- Automatic intelligent averaging smooths noisy signals, while providing a fast display response to real input signal changes.
- UL Listed

### Software Features

- Three-button programming from the front panel (UP, DOWN and PROGRAM buttons).
- Front panel selectable four-level brightness control of digital display, and setpoint LEDs.
- Four programmable setpoints.
- Relay activation can be selected to occur above (HI) or below (LO) each setpoint.
- Hysteresis setting for all four setpoints. Delay on make and delay on break for SP1 and SP2.
- Peak and Valley. View and Reset.

### Specifications

- Input Specs:**.....Series connection to 4-20mA process loop or Single ended 0-10V DC.
- A/D Converter:**.....14 bit single slope
- Accuracy:**..... $\pm(0.05\%$  of reading + 2 counts)
- Temp. Coeff.:**.....100 ppm/ $^{\circ}$ C (Typical)
- Warm up time:**.....2 minutes
- Conversion Rate:**.....5 conversions per second (Typical)
- Display:**.....**4 digit 0.56" Red LED display (std)**, 0.56" or 0.8" Red, Green or Super Bright Red (optn)  
Range -1999 to 9999 counts.
- Polarity:**.....Assumed positive. Displays - negative
- Decimal Selection:**.....Front panel button selectable, X•X•X•X•
- Positive Overage:**..Top segments of digital display flash
- Negative Overage:** Bottom segments of digital display flash
- Relay Output:**.....Two 4 Amp Form A relays and two 9 Amp Form C, or 4 Amp form A relays.
- Analog Output:**.....Isolated 16 bit user scalable mA or V  
AIC (mA out).....4-20 mA @ 0 to 500 $\Omega$  max loop resistance  
AIV (volts out).....0-10 V DC @ 500  $\Omega$  or higher resistance
- Power Supply:**.....AC/DC Auto sensing wide range supply  
**PS1 (std)**.....85-265 VAC 50-400Hz / 95-300 VDC @ 3W  
PS2.....15-48 VAC 50-400HZ / 10-72 VDC @ 2.5W
- Operating Temp.:**.....0 to 50  $^{\circ}$ C
- Storage Temp.:**.....-20  $^{\circ}$ C to 70  $^{\circ}$ C.
- Relative Humidity:**.....95% (non condensing)
- Case Dimensions:**.....1/8 DIN, Bezel: 96x48 mm (3.78"x1.89")  
Depth behind bezel: 117 mm (4.61")  
Plus 11.8 mm (0.47") for Right-angled connectors, or plus 20 mm (0.79") for Straight-thru connector.
- Weight:**.....6.5 oz., 8.5 oz when packed

### Index

Case Dimensions . . . . .	10	Digital Rescaling. . . . .	4	Input Module Component Glossary . . .	9	Software Features . . . . .	1
Component Layout. . . . .	8	Digital Rescaling Procedure. . . . .	4	Lens Cover . . . . .	11	Software Logic Tree . . . . .	3
Connector Pinouts . . . . .	7	Digital Span Selection for Analog		Metal Surround Case . . . . .	11	Specifications . . . . .	1
Controls and Indicators . . . . .	2	Range Output. . . . .	5	Ordering Information . . . . .	12	Two Point Analog Output Range	
Decimal Point & Brightness Selection. .	5	General Features . . . . .	1	Pin Descriptions . . . . .	7	Setting and Calibration. . . . .	5
		Glossary of Programming Symbols . .	2	Setpoint & Relay Configuration Mode. .	6		



## Front Panel Buttons

### Program Button

The **P** button is used to move from one program step to the next. When pressed at the same time as the **↑** button, it initiates the **calibration mode**. When pressed at the same time as the **↓** button, it initiates the **setpoint setting mode**.

### Up Button

When in the operational display, pressing the **↑** button alone, allows you to view and reset the Peak and Valley (Highest and Lowest Readings.)

When in the **calibration mode** or the **setpoint setting mode** the **↑** button is used to increase the value of the displayed parameter.

### Down Button

When in the operational display, pressing the **↓** button alone, allows you to view, but not change, the setting of setpoint 1,2,3 & 4.

When in the **calibration mode** or the **setpoint setting mode** the **↓** button is used to decrease the value of the displayed parameter.

## Glossary of Programming Symbols

To explain software programming procedures, logic diagrams are used to visually assist in following the programming steps. The following symbols are used to represent various functions and associated display elements of the meter:

Symbol	Explanation
	This symbol represents the OPERATIONAL DISPLAY.
	This is the PROGRAM button.
	This is the UP button.
	This is the DOWN button.
	When a button is shown, press and release it to go onto the next step in the direction indicated by the arrow. When two or more buttons are shown, each with an arrow, this indicates that there is a number of programming choices.
	When two buttons are shown side by side and enclosed by a dotted line, they must be pressed at the same time then released to go onto the next programming step.
	If the display is shown with XXXX it means the value displayed will be the previously set value. When a number is shown it indicates the initial factory default setting or a specific "example number".

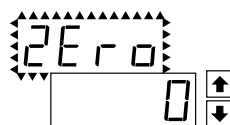

When two displays are shown together with bursts, this indicates that the display is toggling (flashing) between the name of the function and the value.



Text or numbers shown between square brackets in a procedure indicate the programming code name of the function or the value displayed on the meter display.

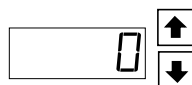

When the **↑** and **↓** buttons are shown together, the display value can be increased by pressing and releasing the **↑** button or decreased by pressing and releasing the **↓** button.

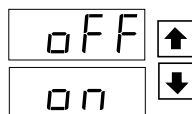

When the **↑** and **↓** buttons are shown with two displays, either display can be selected by pressing and releasing the **↑** or **↓** buttons.

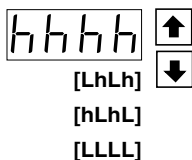

When there are more than two display selections they are shown in brackets below the first display and are also selectable by pressing and releasing the **↑** or **↓** buttons.

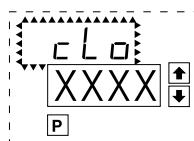

A dotted box indicates these functions are omitted or bypassed when the related hardware is not present

The DL-40PSF-PROCESS is an intelligent meter with a hierarchical software structure designed for easy programming and operation, as shown below in the software logic tree.

After the meter has been powered up, the four digits light up for three seconds and then settle to the operational display indicating the input signal.

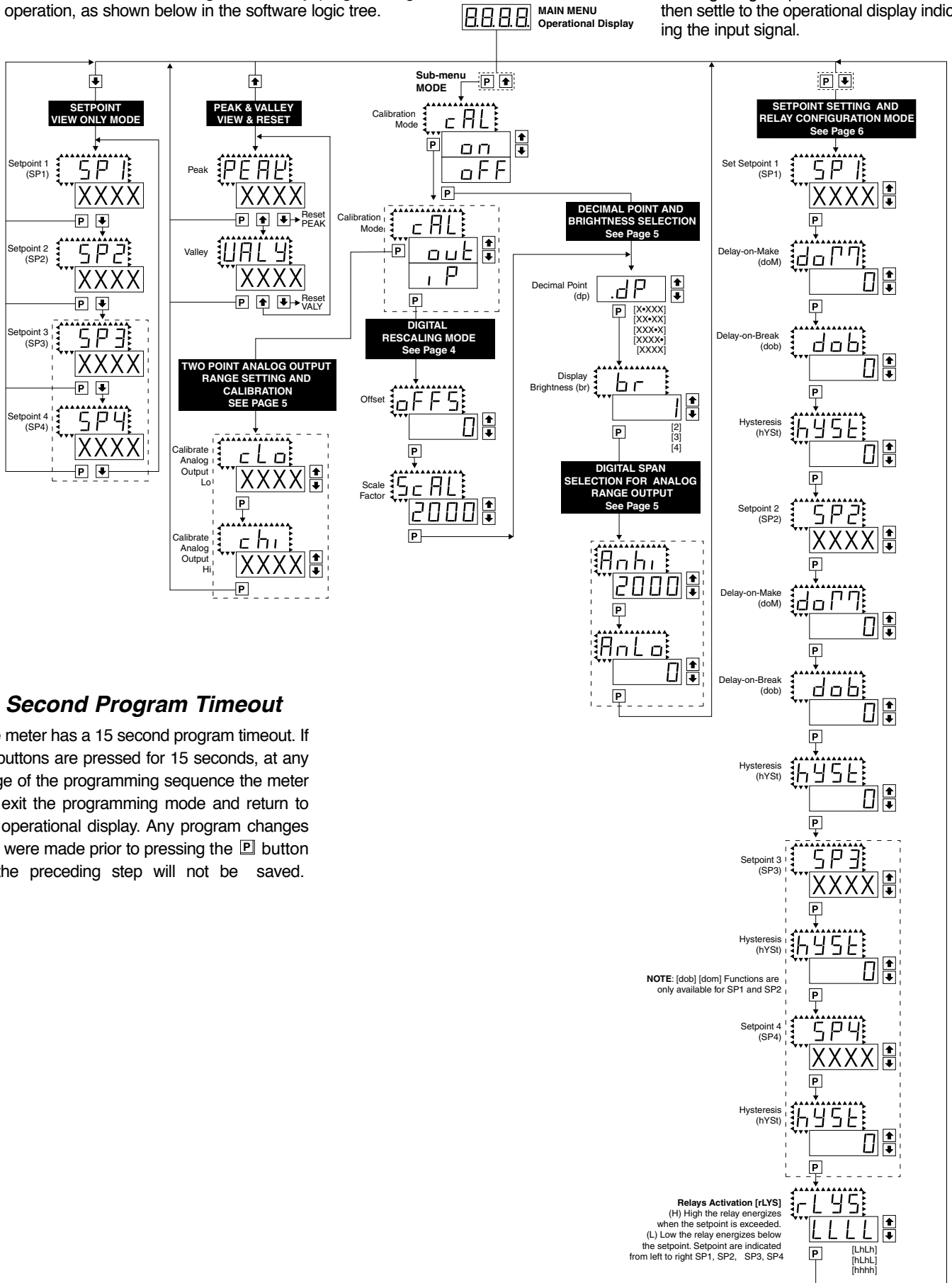

## 15 Second Program Timeout

The meter has a 15 second program timeout. If no buttons are pressed for 15 seconds, at any stage of the programming sequence the meter will exit the programming mode and return to the operational display. Any program changes that were made prior to pressing the **P** button in the preceding step will not be saved.

## Digital Rescaling

The DL-40PSF-PROCESS meter may be rescaled without applying an external signal by changing the Offset and Scale factor.

Offset is the reading that the meter will display for a zero input. The Offset may be set to any value from -1999 to +9999. The default value of the Offset is 000

Scale factor is the gain of the meter. The displayed reading is directly proportional to the Scale factor. The default value of the scale factor is 2000, but it may be set to any value between -1999 and +9999.

For an input of 2V a calibrated meter will read 2000 with the default Scale factor of 2000, 3000 with a Scale factor of 3000 and 500 with a Scale factor of 500

If a linear scale is represented by  $mx + b$ , then the Scale Factor corresponds to the slope 'm' and the Offset corresponds to the intercept 'b'

The internal Signal Span is limited to 3 V DC between - 1 V DC to + 2 V DC. Outputs from an Input Signal Conditioning module that exceed these limits will cause the meter to indicate overrange.

**Note:** Most input signal conditioners have provisions for analog calibration and scaling. If the meter's digital Scale Factor is set to 2000 and Offset set to 0000 then, any pre-calibrated signal conditioner with an output that does not exceed - 1 V to + 2 V, will read correctly in the meter without any further calibration.

## Digital Rescaling Procedure

### STEP A Enter the Calibration Mode

- 1) Press the and buttons at the same time. Display toggles between [cAL] and [oFF].
- 2) Press the or button. Display changes from [oFF] to [on].
- 3) Press the button. Display toggles between [cAL] and [out].

### STEP B Select Between Calibration of Input or Output

**Note:** If the analog output option is not present, Step B is skipped and the program goes directly from Step A to Step C.

- 1) Press the or button to select the display toggling from [cAL] to [iP].
- 2) Press the button. Display toggles between [oFFS] and the previous offset setting.

### STEP C Set the Offset on the Digital Display

- 1) Using the and buttons, adjust the digital display to the desired offset. This is the reading that the meter will display for a zero input
- 2) Press the button. Display toggles between [ScAL] and the previous Scale factor.

### STEP D Set the Scale factor on the Digital Display

- 1) Using the and buttons, adjust the meter display to the desired Scale factor. The default value is 2000, for which a 2V input will read 2000. If the scale factor is changed the display will change proportionately. Therefore if the Scale factor is changed to 1000 then for the same 2V input the display would read 1000.
- 3) Press the button.

### The Digital Calibration Procedure Mode is Now Complete.

The menu branches to the DECIMAL POINT AND BRIGHTNESS SELECTION, (see page 5) and the display flashes [dP] and the previous decimal point selection.

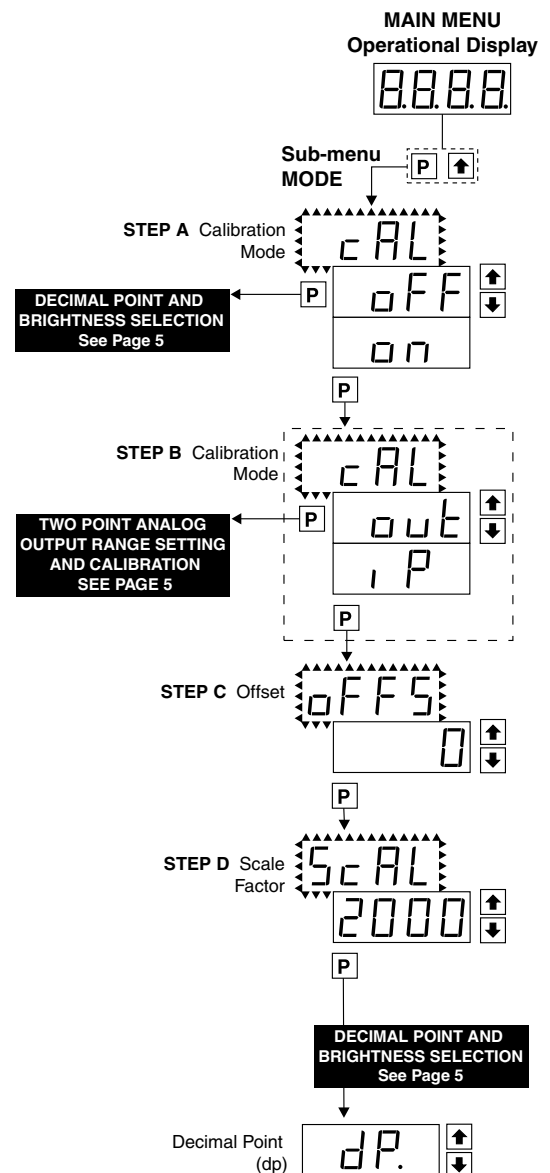

## Two Point Analog Output Range Setting and Calibration

### STEP A Enter the Calibration Mode

- 1) Press the **P** and **↔** buttons at the same time. Display toggles between [cAL] and [oFF].
- 2) Press the **↑** or **↓** button. Display changes from [oFF] to [on].
- 3) Press the **P** button. Display toggles between [cAL] and [out] input calibration.

**Note:** If at this point the display skips directly to toggle between [oFFS] and the previous [oFFS] setting, the software is detecting that the optional analog output hardware is NOT installed.

### STEP B Enter the Analog [oUT] Output Mode

- 1) Press the **P** button. Display toggles between [cLo] and an internal scale factor.

### STEP C Set or Calibrate the [cLo] Low Analog Output Range

- 1) Select the voltage or current loop output header position on the output module. (See Component Layout on page 9).
- 2) Connect a multimeter to pins 16 and 17 on the output module. (See Rear Panel Pinouts on page 8). Using the **↑** and **↓** buttons, adjust the analog output to the desired low value as shown on the multimeter display. cLo may be adjusted to any value from -0.3 mA to 17 mA (mA output selected) or from -0.6 V to 8 V (volt output selected)
- 3) Press the **P** button. Display toggles between [cHi] and an internal scale factor.

### STEP D Set or Calibrate the [cHi] High Analog Output Range

- 1) Using the **↑** and **↓** buttons, adjust the analog output to the desired high value as shown on the multimeter display. cHi may be adjusted to any value from 17 mA to 21 mA (mA output selected) or from 8 V to 10.3 V (volt output selected)
- 2) Press the **P** button. The display exits the calibration mode and returns to the operational display.

**Note:** Having established the Low and High range of the analog output, the digital span can now be selected which will set the two digital points between which the analog output will occur. (See Digital Span Selection below).

## Decimal Point and Brightness Selection

### STEP A Enter the Decimal Point and Brightness Mode Through the Sub Menu [CAL] [oFF]

- 1) Press the **P** and **↔** buttons at the same time. Display toggles between [cAL] and [oFF].
- 2) Press the **P** button. Display shows previous [dp] selection.

### STEP E Set the Decimal Point

- 1) Using the **↑** and **↓** buttons, adjust the display to the desired decimal point setting.
- 2) Press the **P** button. Display toggles between [Br] and the previous [Br] setting.

### STEP F Set the Display Brightness

- 1) Using the **↑** and **↓** buttons, adjust the display to the desired brightness setting (4 is the brightest setting).
- 2) Press the **P** button. Display brightness changes to new setting and display toggles between [Anhi] and the previous [Anhi] setting.

## Digital Span Selection for Analog Range Output

### STEP G Setting the Digital Span Point for Analog High Output

- 1) Using the **↑** and **↓** buttons, adjust the display to the desired digital value which sets the point at which the selected analog high output range will occur.
- 2) Press the **P** button. Display toggles between [AnLo] and previous [AnLo] setting.

### STEP H Setting the Digital Span Point for Analog Low Output

- 1) Using the **↑** and **↓** buttons, adjust the display to the desired digital value which sets the point at which the selected analog low output range will occur.
- 2) Press the **P** button. The display exits the calibration mode and returns to the operational display.

**Note:** Any two digital scale points from -1999 to 9999 can be selected. The digital scale points for analog high and analog low can be reversed for reversed 20-4 mA output. The span of the digital scale can be as small as two counts however small spans cause the 16 bit D to A to increment in stair case steps.

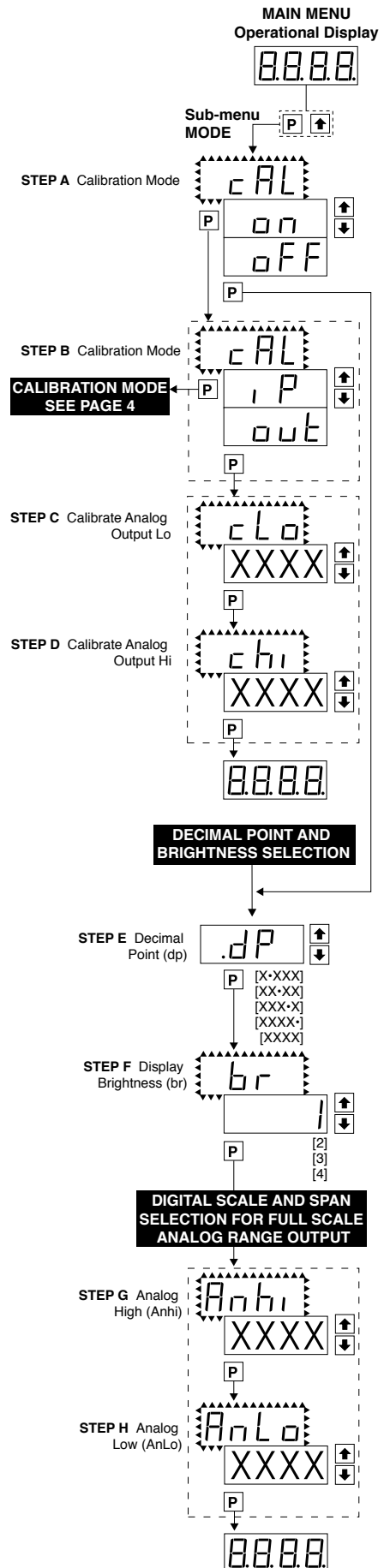

# Setpoint Setting and Relay Configuration Mode

The following programming steps are required to enter the setpoint values and configure the relay functions in a meter with four relays using four setpoints. Generally if less than four relays are installed the software auto detects missing relays and deletes reference to them from the menu. In some cases setpoints without relays are operational for display only purposes.

## STEP A Enter the Setpoint Mode

- 1) Press the **[P]** and **[↓]** buttons at the same time.  
Display toggles between [SP1] and the previous [SP1] setting.

## STEP B Set Setpoint 1 (SP1)

- 1) Using the **[↑]** and **[↓]** buttons, adjust the display to the desired SP1 value.
- 2) Press the **[P]** button. Display toggles between [doM] and the previous [doM] setting.

## STEP C Set the SP1 Delay-on-Make (doM) Delay Time Setting

- 1) Using the **[↑]** and **[↓]** buttons, adjust the display to the desired [doM] value (0 to 9999 seconds). The reading must continuously remain in an alarm condition until this delay time has elapsed before the relay will make contact (energize).
- 2) Press the **[P]** button. Display toggles between [dob] and the previous [dob] setting.

## STEP D Set the SP1 Delay-on-Break (dob) Delay Time Setting

- 1) Using the **[↑]** and **[↓]** buttons, adjust the display to the desired [dob] value (0 to 9999 seconds). The reading must continuously remain in a non-alarm condition until this delay time has elapsed before the relay will break contact (de-energize).
- 2) Press the **[P]** button. Display toggles between [hYSt] and the previous [hYSt] setting.

## STEP E Set the Hysteresis Setting for Setpoint 1

- 1) Using the **[↑]** and **[↓]** buttons, adjust the display to the desired hysteresis [hYSt] value.
  - 2) Press the **[P]** button. Display toggles between [SP2] and the previous [SP2] setting.
- NOTE:** Half of the Hysteresis value selected is applied above and below the setpoint.

**NOTE:** Steps F, G, H and J have functionally the same procedure as steps B, C, D, and E shown above.

## STEP F Set Setpoint 2 (SP2)

## STEP G Set the SP2 Delay-on-Make (doM) Delay Time Setting

## STEP H Set the SP2 Delay-on-Break (dob) Delay Time Setting

## STEP I Set the Hysteresis Setting for Setpoint 2

- 1) Using the **[↑]** and **[↓]** buttons, adjust the display to the desired hysteresis [hYSt] value.
- 2) Press the **[P]** button. Display toggles between [SP3] and the previous [SP4] setting.

## STEP J Set Setpoint 3 (SP3) (No [doM] or [dob])

- 1) Using the **[↑]** and **[↓]** buttons, adjust the display to the desired SP3 value.
- 2) Press the **[P]** button. Display toggles between [hYSt] and the previous [hYSt] setting.

## STEP K Set the Hysteresis Setting for Setpoint 3

- 1) Using the **[↑]** and **[↓]** buttons, adjust the display to the desired hysteresis [hYSt] value.
- 2) Press the **[P]** button. Display toggles between [SP4] and the previous [SP4] setting.

## STEP L Set Setpoint 4 (SP4) (No [doM] or [dob])

- 1) Using the **[↑]** and **[↓]** buttons, adjust the display to the desired SP4 value.
- 2) Press the **[P]** button. Display toggles between [hYSt] and 0.

## STEP M Set the Hysteresis Setting for Setpoint 4

- 1) Using the **[↑]** and **[↓]** buttons, adjust the display to the desired hysteresis [hYSt] value.
- 2) Press the **[P]** button. Display toggles between [rLYS] and the previous relay setting.

## STEP N Set Relay Activation mode [rLYS]

(h) High the relay energizes when the setpoint is exceeded. (L) Low the relay energizes below the setpoint. The setpoint is indicated from left to right SP1, SP2, SP3, SP4.

- 1) Using the **[↑]** and **[↓]** buttons, adjust the reading on the display to the desired relay settings: [LLLL], [LhLh], [hLhL], [hhhh].  
If only 2 relays installed [Lh--], [hL--], [hh--], [LL--].
- 2) Press the **[P]** button.  
The meter exits the setpoint mode and returns to the operational display.

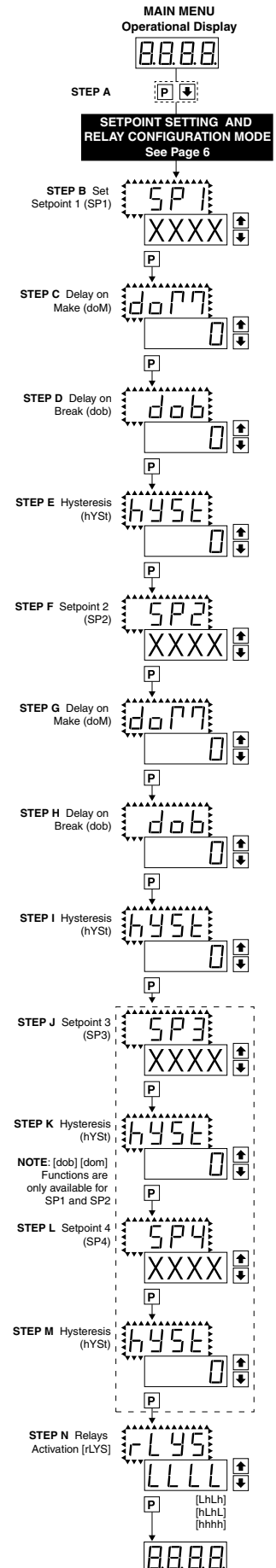

The Setpoint Relay programming mode is now complete.

## Connector Pinouts

### Pinout Diagram

The Rear View of the Meter diagram shows the meter with the relay configuration: dual 9 Amp Form C and dual 4 Amp Form A relays. An analog output module is also shown as installed.

The DL-40PSF-PROCESS use plug-in type screw terminal connectors for all input and output connections. The power supply connections (pins 14 and 15) have a unique plug and socket outline to prevent cross connection. The main board and input signal conditioner use right-angled connectors as standard. The output module uses straight-thru connectors as standard.



**WARNING:** AC and DC input signals and power supply voltages can be hazardous. Do Not connect live wires to screw terminal plugs, and do not insert, remove or handle screw terminal plugs with live wires connected.

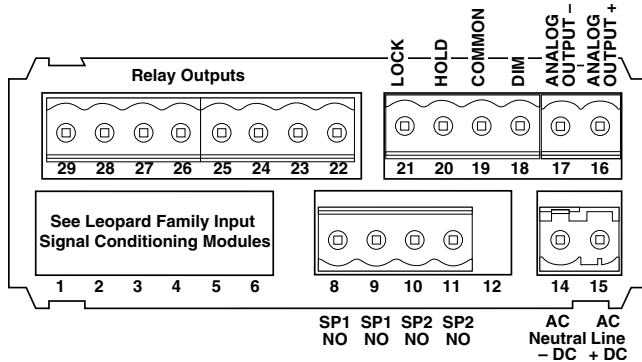

Auto-sensing AC/DC power supply. For voltages between 85-265 V AC / 95-300 V DC (PS1) or 18-48 V AC / 10-72 V DC (PS2).

## Pin Descriptions

### Pins 1 to 3 – Input Signal

Pin 1 to 3 Input

### Pins 8 to 12 – Relay Output Pins

Note: If relays for setpoints 1 & 2 are installed on the main board, and a relay output module is used that also has relays in the setpoints 1 & 2 positions, the duplicate relays will operate in unison.

- Pin 8 SP1 NO.
- Pin 9 SP1 NO. Normally Open 4 Amp Form A.
- Pin 10 SP2 NO.
- Pin 11 SP2 NO. Normally Open 4 Amp Form A.
- Pin 12 NO CONNECTION.

### Pins 14 and 15 – AC/DC Power Input

Auto-sensing AC/DC power supply. For voltages between 85-265 V AC/95-300 V DC (PS1) or 18-48 V AC/10-72 V DC (PS2).

- Pin 14 AC/DC Neutral. Neutral power supply line.
- Pin 15 AC/DC line. Live power supply line.

## Optional Carrier Board Output Pins

### Pins 16 and 17 – Analog Output

Pins 16 and 17 are the analog output pins on the optional output module. Their pin definitions are:

- Pin 16 Positive (+) analog output.
- Pin 17 Negative (-) analog output.

### Pins 18 to 21 – Rear Panel Function Pins

Pins 18 to 21 provide functions that can be implemented with an external switch. Their pin definitions are:

- Pin 18 DIM. By connecting the display dim (DIM) pin to the COMMON pin, the display brightness setting is halved.
- Pin 19 COMMON. To activate the LOCK or DIM functions from the rear of the meter, the respective pins have to be connected to the COMMON pin. This pin is connected to the internal power supply ground.

## Pin Descriptions (continued)

- Pin 20 HOLD. By connecting the HOLD pin to the COMMON pin, the displayed reading is frozen, however, A/D conversions continue. When the HOLD pin is disconnected from the COMMON pin, the correct reading is displayed.
- Pin 21 LOCK. By connecting the LOCK pin to the COMMON pin, the meter's programmed parameters can be viewed but not changed.

## Pins 22 to 29 – Output Module Pins

### Relay Modules with 4 Independent 300V (210mA DC only)

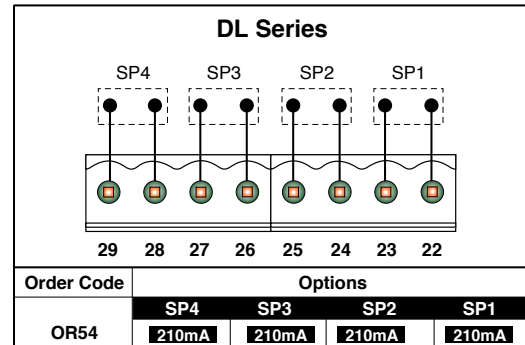

### Relay Modules with 2 Non-Isolated 4A Form A Relays, and 2 Non-Isolated 9A Form C Relays

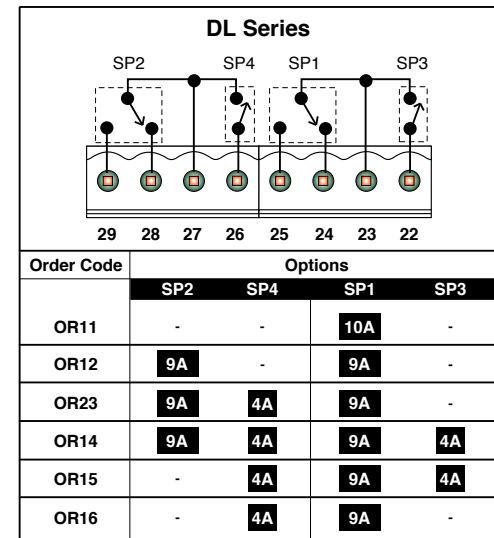

### Relay Modules with 4 Isolated 5A Form A Relays

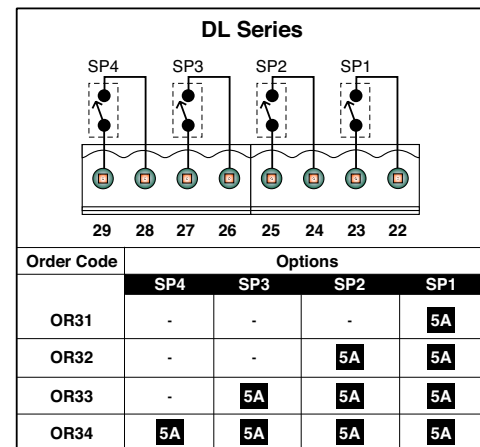

**MAIN BOARD**

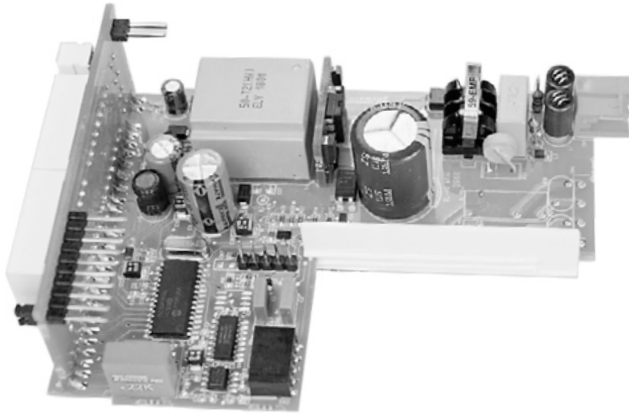

**MAIN BOARD HI BOLTAGE**

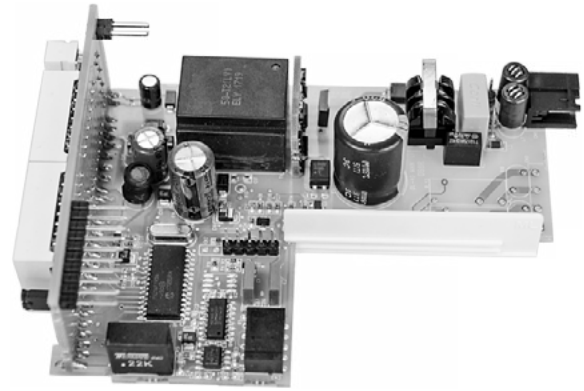

**MAIN BOARD LOW BOLTAGE**

**4-20mA INPUT MODULE**

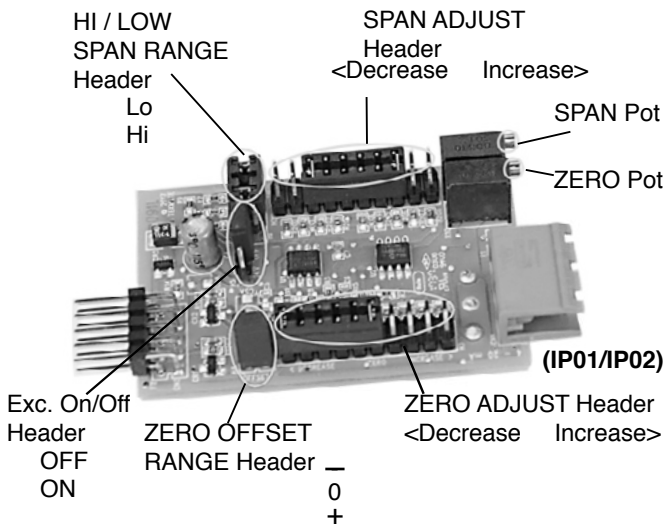

**4 to 20mA Process Loop Measurement**

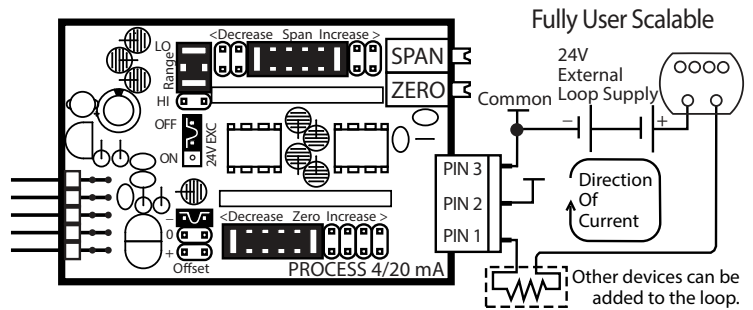

Order IP02, if you require the loop excitation voltage to be supplied by the meter.

**0-10V INPUT MODULE**

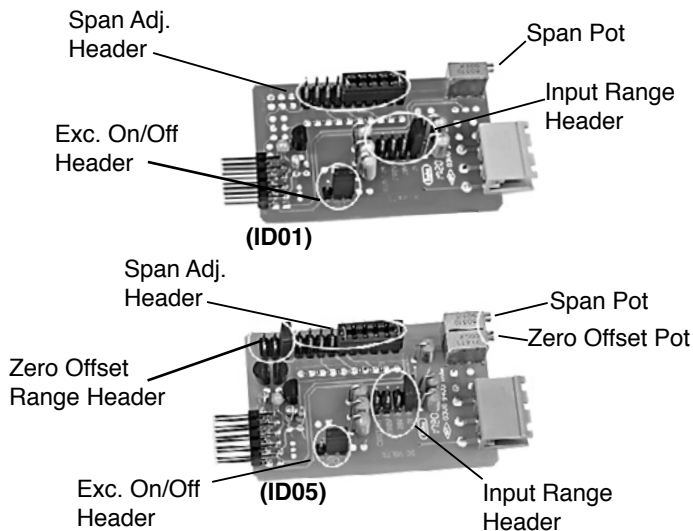

ID01: DC Volts, 2/20/200V/Custom w/24V DC Exc

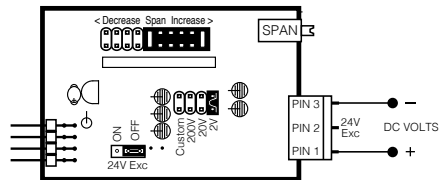

ID05: DC Volts 2/20/200/Custom V DC with Offset and 24V Exc.

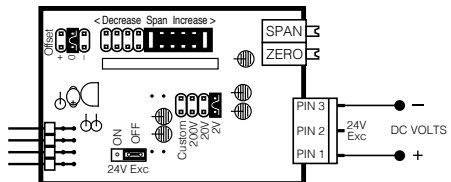



# Input Module Component Glossary

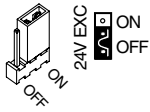

## 24V DC Output Header

On some modules this header enables a 24V DC 25mA (max) Excitation/Auxiliary output to be connected to Pin 2.

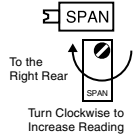

## SPAN Potentiometer (Pot)

If provided, the 15 turn SPAN pot is always on the right side (as viewed from the rear of the meter). Typical adjustment is 20% of the input signal range.

## SPAN ADJUST Header

This unique five-position header expands the adjustment range of the SPAN pot into five equal 20% steps, across 100% of the input Signal Span. Any input Signal Span can then be precisely scaled down to provide any required Digital Display span from 1999 counts to 001 (one count).

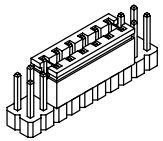

SPAN Adjust Header position	1	2	3	4	5
SPAN Pot %	20%	20%	20%	20%	20%
Signal Span %	20%	40%	60%	80%	100%

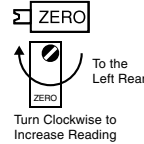

## ZERO Potentiometer (Pot)

If provided, the ZERO pot is always to the left of the SPAN pot (as viewed from the rear of the meter). Typically it enables the input signal to be offset  $\pm 5\%$  of full scale (-100 to +100 counts).

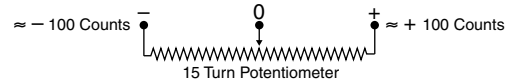

## ZERO OFFSET RANGE Header

When provided, this three position header increases the ZERO pot's capability to offset the input signal, to  $\pm 25\%$  of the digital display span. For example a Negative offset enables a 1 to 5V input to display 0 to full scale. The user can select negative offset, positive offset, or no offset (ZERO pot disabled for two step non-interactive span and offset calibration).

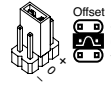

Zero Offset Range Header

Header Position	NEGATIVE OFFSET Decreases Digital Reading	NO OFFSET Zero Pot Disabled	POSITIVE OFFSET Increases Digital Reading
ZERO Pot %	- 100% of Offset	0	+ 100% of Offset
Offset Range	$\ominus$ - 500 Counts		$\oplus$ + 500 Counts



## SPAN RANGE Header

When this header is provided it works in conjunction with the SPAN ADJUST Header by splitting its adjustment range into a Hi and a Lo range. This has the effect of dividing the adjustment range of the SPAN pot into ten equal 10% steps across 100% of the input Signal Span.

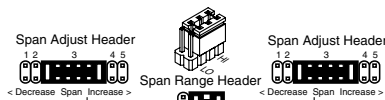
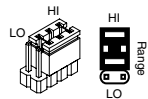

SPAN Adjust Header position	1	2	3	4	5	1	2	3	4	5
SPAN Pot %	10%	10%	10%	10%	10%	10%	10%	10%	10%	10%
Signal Span %	10%	20%	30%	40%	50%	60%	70%	80%	90%	100%

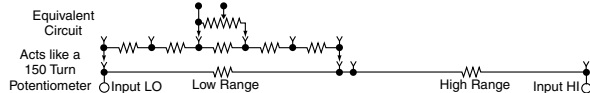

## ZERO ADJUST Header

When this header is provided, it works in conjunction with the ZERO OFFSET RANGE Header, and expands the ZERO pot's offset capability into five equal negative steps or five equal positive steps. This enables virtually any degree of input signal offset required to display any desired engineering unit of measure.

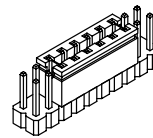

Zero Offset Range Header

Header Position	5	4	3	2	1	Header Position	1	2	3	4	5
ZERO Adjust Header position	5	4	3	2	1	Zero Pot Disabled	1	2	3	4	5
ZERO Pot %	-20%	-20%	-20%	-20%	-20%		+20%	+20%	+20%	+20%	+20%
Offset Range	-1200 or more counts						+1200 or more counts				

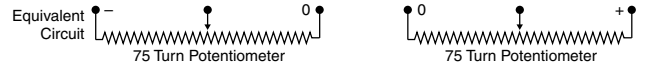

## Installation

1. Install and wire meter per local applicable codes/regulations, the particular application, and good installation practices.
2. Install meter in a location that does not exceed the maximum operating temperature and that provides good air circulation.
3. Separate input/output leads from power lines to protect the meter from external noise. Input/output leads should be routed as far away as possible from contactors, control relays, transformers and other noisy components. Shielding cables for input/output leads is recommended with shield connection to earth ground near the meter preferred.
4. A circuit breaker or disconnect switch is required to disconnect power to the meter. The breaker/switch should be in close proximity to the meter and marked as the disconnecting device for the meter or meter circuit. The circuit breaker or wall switch must be rated for the applied voltage (e.g., 120VAC or 240VAC) and current appropriate for the electrical application (e.g., 15A or 20A).
5. See *Case Dimensions* section for panel cutout information.
6. See *Connector Pinouts* section for wiring.
7. Use 28-12 AWG wiring, minimum 90°C (HH) temperature rating. Strip wire approximately 0.3 in. (7-8 mm).
8. Recommended torque on all terminal plug screws is 4.5 lb-in (0.51 N-m).

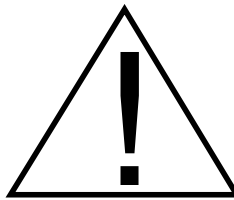

## Case Dimensions

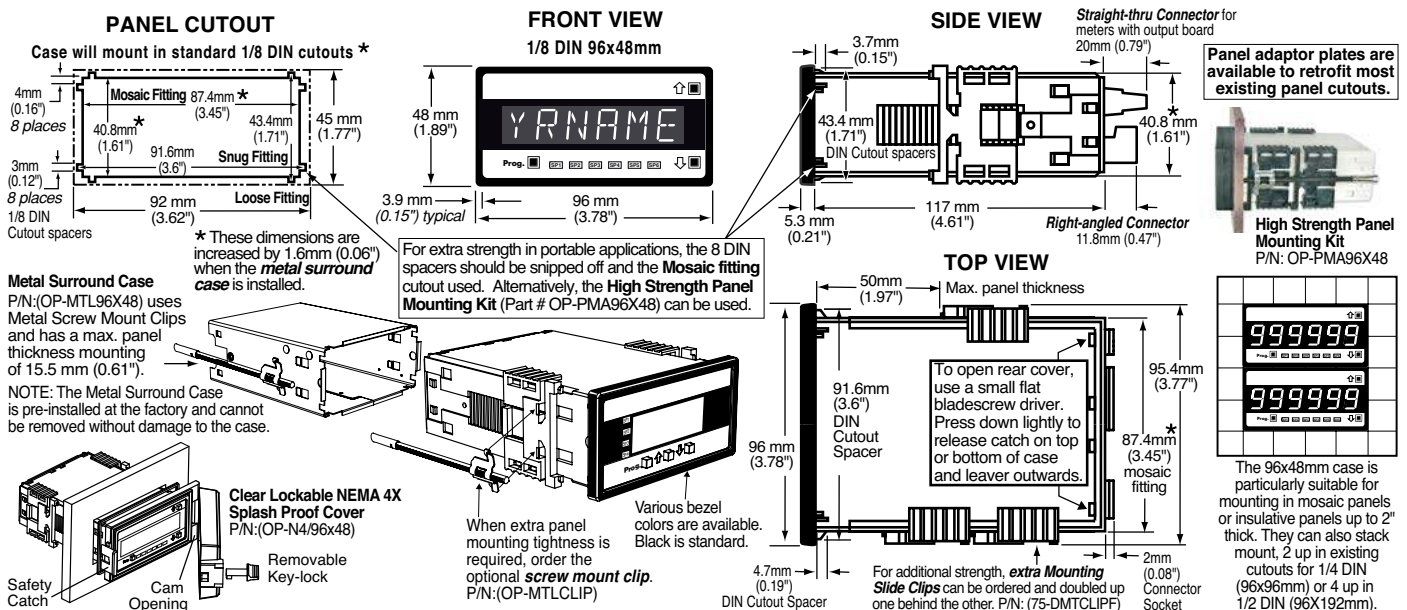

## Clear Lockable Water-proof Lens Cover OP-N4X/96X48

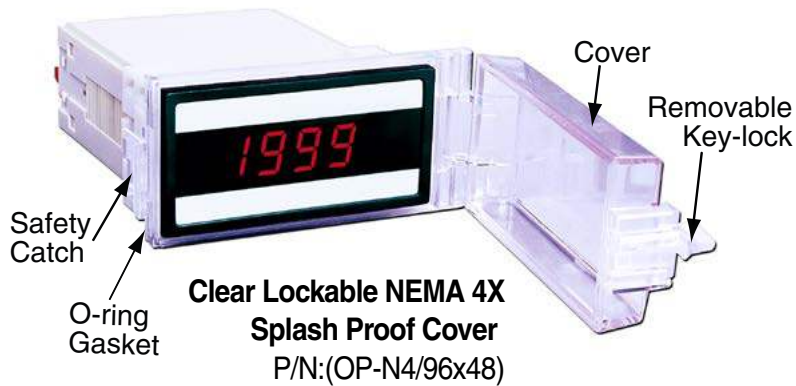

The clear lockable cover is designed to be dust and water proof to NEMA-4X, IP65 standards. The assembly consists of a base and cover with a cam hinge and key-lock fastening mechanism. An O-ring, or neoprene gasket forms a seal between the base and the panel. The cam hinge prevents the cover from closing when opened until pushed closed. The cover has a tapered recess that, when closed, forms a seal with a tapered spigot on the base. A key-lock employs a cam locking device to force the spigot into the recess, ensuring seal integrity. A safety catch keeps the cover closed even when the key is removed, and the keyhole can be used to attach a safety seal clip, preventing unauthorized opening.

## Metal Surround Case Option OP-MTL96X48

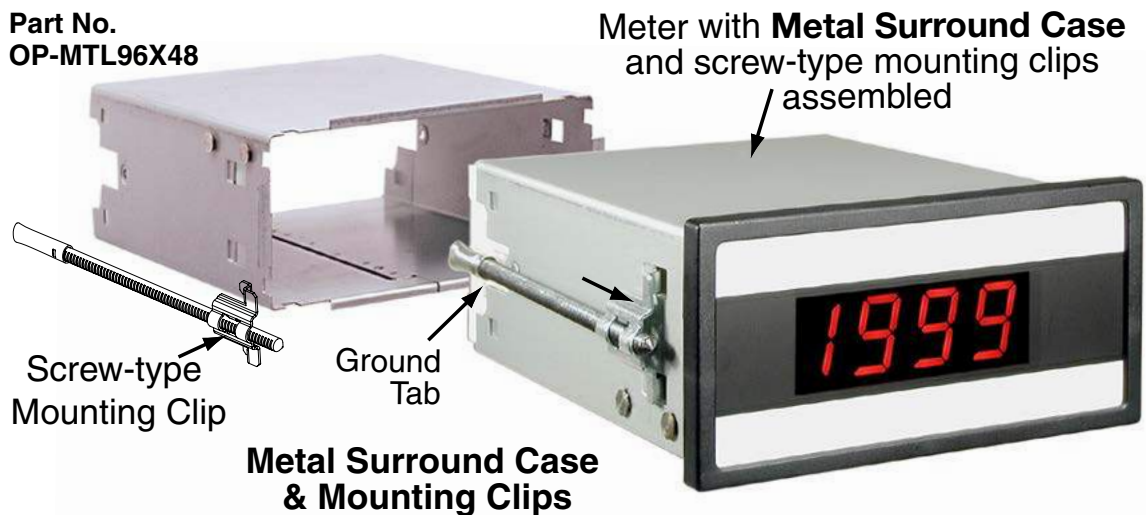

The meter's plastic case is made from fire retardant polycarbonate. A metal surround case can be ordered to enhance the meter's fire retardant capabilities and also provide shielding against electromagnetic interference (EMI). The metal case slides over the polycarbonate case and is held firmly in place by spring-type non-return clips. The Metal Surround Case must be factory installed on the polycarbonate case and once installed, it cannot be removed in the field.

With the metal case in place, the meter's standard ratchet-type mounting clips can not be used. Instead a pair of screw-type DIN standard mounting clips are provided, which clip into holes on the side of the metal case and tighten against the rear of the panel. A ground tab on the metal case enables the metal case to be easily connected to the panel ground.

# Ordering Information



Add to the basic model number the order code suffix for each standard option required. The last suffix is to indicate how many different special options and or accessories that you may require to be included with this product. \*Except when when R1 or R2 relay output is selected, a meter ordered with an analog output or a relay output module requires an Output Module Carrier Board

**Ordering Example: DL-40PSF-PROCESS-DR-PS1-IP01-AIC-R1-OA2, the 2 OA's are, ZR and a OP-N4X/96X48**

**► BASIC MODEL NUMBER**  
DL-40PSF-PROCESS

96x48, Leopard, 4 Digit, Process .....

**Standard Options for this Model Number**

Order Code Suffix	Description	List
<b>► DISPLAY</b>		
DR.....	Red LED, 0.56 inch high .....	
DB.....	Super-bright Red LED, 0.56 inch high .....	
DG.....	Green LED, 0.56 inch high .....	
LG.....	Large Green LED, 0.8 inch high .....	
LR.....	Large Red LED, 0.8 inch high .....	

<b>► POWER SUPPLY</b>		
PS1.....	.85 - 265VAC / 95 - 300VDC .....	
PS2.....	18 - 48VAC / 10 - 72VDC .....	

<b>► INPUT MODULES (Partial List. See www.texmate.com)</b>		
Unless otherwise specified Texmate will ship all modules precalibrated with factory preselected ranges and/or scalings as shown in <b>BOLD</b> type		
IP01..	Process Loop, <b>4-20mA(0-100.0)</b> .....	
IP02..	Process Loop, <b>4-20mA(0-100.0)</b> w/24VDC Exc. ....	
ID01..	DC-Volts, <b>2/20/200V/Custom</b> w/24V DC Exc. ....	
ID05..	DC-Volts <b>2/20/200/Custom</b> V DC w/Offset and 24V Exc. ....	

<b>► ANALOG OUTPUT *Add \$7 for an Output Module Carrier Board</b>		
AIC.....	Isolated 16 Bit Current Output, 0-20mA and 4-20mA, pls. specify ..	
AIV.....	Isolated 16 Bit Voltage Output, 0-10VDC .....	

<b>► RELAY OUTPUT</b>		
<b>Note:</b> R1 and R2 are located on the main board, and are generally used when only two Form A Relays or less are required and an Analogy Output is not required.		
R1.....	Single 5A Form A Relay .....	
R2.....	Dual 5A Form A Relays .....	

<b>► RELAY OUTPUT MODULES</b>		
<b>Note:</b> If a meter is ordered with a Relay Output Module, but without Analog output, an Output Module Carrier Board should be automatically added to the order.		
OR11..	One 10 Amp Form C Relay, Isolated .....	
OR15..	One 10 Amp Form C and Two 5 Amps Form A Relays .....	
OR16..	One 10 Amp Form C and One 5 Amp Form A Relays .....	
OR12..	Two 10 Amp Form C Relays, Isolated .....	
OR14..	Two 10 Amp Form C and Two 5 Amps Form A Relays .....	
OR23..	Two 10 Amp Form C and One 5 Amp Form A Relay, Isolated ..	
OR31..	One 5 Amp Form A Relay, Isolated .....	
OR32..	Two 5 Amp Form A Relays, Isolated .....	
OR33..	Three 5 Amp Form A Relays, Isolated .....	
OR34..	Four 5 Amp Form A Relays, Isolated .....	

<b>Solid State Relay (SSR) Output Modules DC Only</b>		
OR54..	Four 400V DC Solid State Relays (SSR) 210mA.....	

**Special Options and Accessories (OA's)**

Part Number	Description	List
<b>► SPECIAL OPTIONS (Specify Inputs or Outputs &amp; Req. Reading)</b>		
<b>Output Module Carrier Board</b>		
*One carrier board must be ordered with any meter that includes any one or more of the following options: Analog Output and/or Relay Output Modules.		
SA-DL/OM-CB	Output Module Carrier Board, DL series .....	
ZR.....	Range Change from Standard Range shown in <b>BOLD</b> type .....	
ZS.....	Custom display scaling within standard ranges .....	
ZS-AO.....	Custom scaling of analog output .....	

<b>► ACCESSORIES</b>		
75-DBBZ9648F	Black Bezel for 96x48mm Case. ....	
75-DMTCLIPF	Side Slide Brackets (2 pc) - extra set, extra strength ..	
76-DL40G-N4	"Touch" Green LED Faceplate, NEMA 4, Factory install ..	
76-DL40LG-N4	"Touch" Large Green LED Faceplate, NEMA 4, Factory install	
76-DL40LR-N4	"Touch" Large Red LED Faceplate, NEMA 4, Factory install ..	
76-DL40R-N4	"Touch" Red LED Faceplate, NEMA 4, Factory install. .	
ART-FS-S/D	NRC for artwork & set-up Faceplate/Desc. ....	
ART-FS1	Install Custom Faceplate per meter - 1 color. ....	
ART-FS2	Install Custom Faceplate per meter - 2 color. ....	
ART-FS3	Install Custom Faceplate per meter - 3 color. ....	
ART-FS4	Install Custom Faceplate per meter - 4 color. ....	
OP-MTLCLIP	Screw Mounting Clips (2 pc) - to screw tighten slide brackets	
OP-MTL96X48	Metal Surround Case, includes screw mounting clips ..	
OP-N4X/96X48	96x48mm clear lockable front cover-NEMA 4X, splash proof	

**Prices subject to change without notice.**

**WARRANTY**

Texmate warrants that its products are free from defects in material and workmanship under normal use and service for a period of one year from date of shipment. Texmate's obligations under this warranty are limited to replacement or repair, at its option, at its factory, of any of the products which shall, within the applicable period after shipment, be returned to Texmate's facility, transportation charges pre-paid, and which are, after examination, disclosed to the satisfaction of Texmate to be thus defective. The warranty shall not apply to any equipment which shall have been repaired or altered, except by Texmate, or which shall have been subjected to misuse, negligence, or accident. In no case shall Texmate's liability exceed the original purchase price. The aforementioned provisions do not extend the original warranty period of any product which has been either repaired or replaced by Texmate.

**USER'S RESPONSIBILITY**

We are pleased to offer suggestions on the use of our various products either by way of printed matter or through direct contact with our sales/application engineering staff. However, since we have no control over the use of our products once they are shipped, **NO WARRANTY WHETHER OF MERCHANTABILITY, FITNESS FOR PURPOSE, OR OTHERWISE** is made beyond the repair, replacement, or refund of purchase price at the sole discretion of Texmate. Users shall determine the suitability of the proDXct for the intended application before using, and the users assume all risk and liability whatsoever in connection therewith, regardless of any of our suggestions or statements as to application or construction. In no event shall Texmate's liability, in law or otherwise, be in excess of the purchase price of the product.

Texmate cannot assume responsibility for any circuitry described. No circuit patent or software licenses are implied. Texmate reserves the right to change circuitry, operating software, specifications, and prices without notice at any time.



1934 Kellogg Ave., Carlsbad, CA 92008  
Tel: 1-760-598-9899 • 1-800-TEXMATE  
Fax: 1-760-598-9828 • Email: orders@texmate.com

**DL-40PSF-PROCESS Technical Manual Copyright © 2019 Texmate Inc. All rights reserved. Published by: Texmate Inc. USA. Information in this Technical Manual is subject to change without notice due to correction or enhancement. The information described in this manual is proprietary to Texmate, Inc. and may not be copied, reproduced or transmitted, in whole or in part, in connection with the design, manufacture, or sale of apparatus, device or private label product without the express written consent of Texmate, Inc.**