

1 Description

The RedRock 120 Series is an integrated digital magnetic sensor ideal for use in medical, industrial, automotive and consumer switching applications. Based on patented Tunneling Magnetoresistance (TMR) technology with CMOS process, the RR120 Series can function even in low magnetic fields with large air gaps. The RR120 Series provides high sensitivity with low power consumption in a small footprint package.

*Please note: the RR120 Series is not recommended for new designs. Please reference the RR121.



2 Features

- ▶ High sensitivity
- ▶ Stable temperature performance
- ▶ Resistant to mechanical stress
- ▶ Low power consumption
- ▶ High frequency performance
- ▶ Logic output for design flexibility
- ▶ REACH Compliant
- ▶ RoHS Compliant

3 Applications

- ▶ Door or lid closure detection
- ▶ Smart phones, tablets and laptops
- ▶ Bare glass reed switch replacement
- ▶ Motor controllers
- ▶ Proximity detection
- ▶ Open-close detection
- ▶ Water, electric and gas meters
- ▶ Fluid level detection
- ▶ "Wake-Up" functionality

4 Dimensions *Millimeters (Inches)*

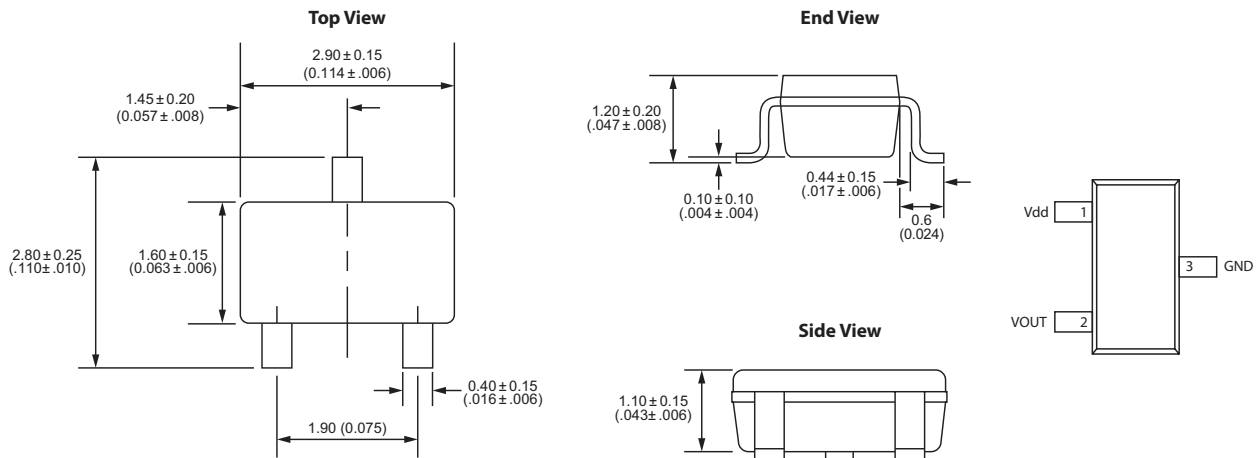

5 Device Nomenclature

Ordering Information

Part Number	RR120-A X 1 X-X 0
Model Number	Package
Magnetic Sensitivity (G)	0 - SOT-23
A - Op = 30 Rel = 15	Special Feature
Temp Rating (°C)	0 - N/A
1 - Industrial (-40-+85)	Magnetic Polarity
Power Rating	1 = Unipolar
1 - Default Value	

6 Specifications

Parameters	Units	Min	Typ	Max
OPERATING CHARACTERISTICS¹				
Operate Sensitivity	G	20	30	40
Release Sensitivity	G	8	15	25
Hysteresis	G		15	
Operate Time	ms		30	
Release Time	ms		30	
Temperature Coefficient of Operate Sensitivity	G/°C		-0.07	
ELECTRICAL CHARACTERISTICS¹				
Supply Voltage (V_{dd})	V	2.7	3.0	3.6
Average Current Drain	nA		250	
Output Voltage (High) ² (V_{outh})	V		2.7 V	
Output Voltage (Low) ² (V_{outl})	V		0.2 V	
ABSOLUTE ENVIRONMENTAL RATINGS				
Operating Temperature: Industrial	°C	-40		85
Storage Temperature	°C	-55		150
Soldering Temperature (3 cycles, 1 min.)	°C			260
Operating Magnetic Field	G			100
ESD Level (HBM)	V			4000

Notes:

1. All characteristics as measured at 25°C
2. See "Magnetic Field vs. Output Status" (at right) for more details.

7 Sensor Polarity Diagram

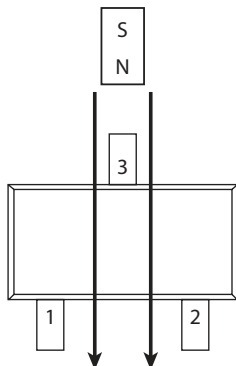

8 Digital Function Block Diagram

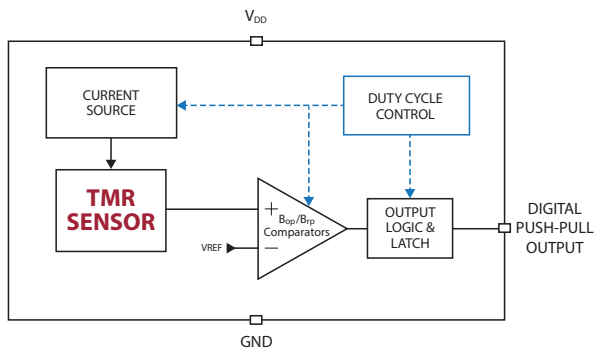

9 Magnetic Field vs. Output Status

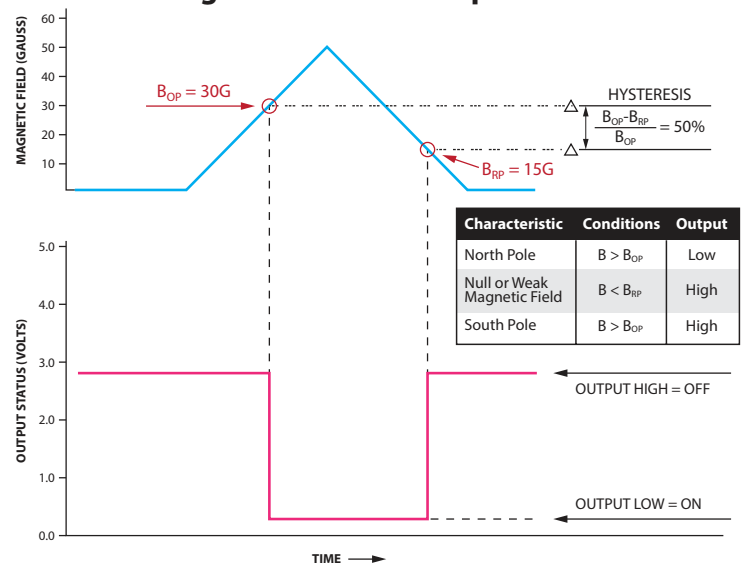

10 MTJ Sensor Location Diagram

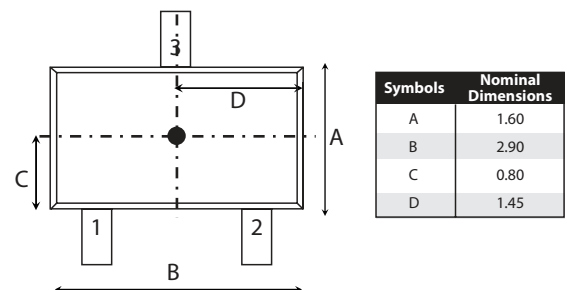

11 TMR Sensor & Switch Packaging

Standard packaging is Tape & Reel containing 3,000 pieces. Below is a chart of Tape & Reel dimensions for standard TMR products.

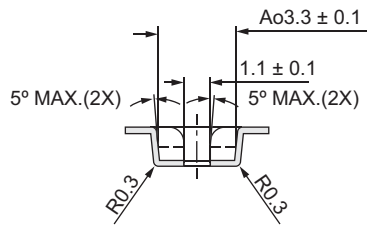
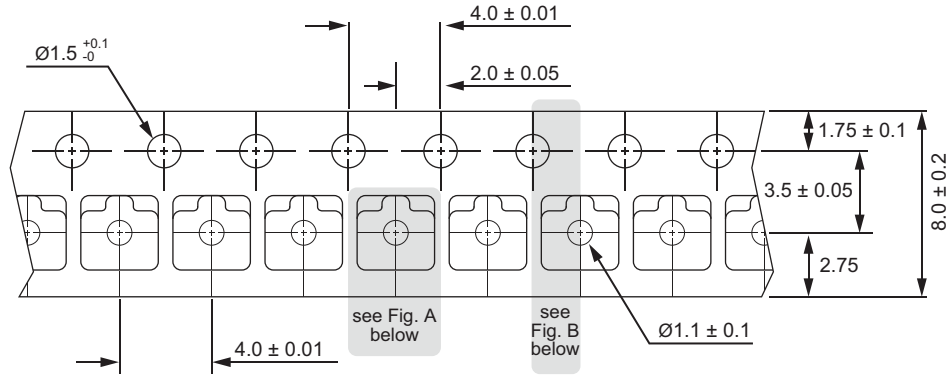

Fig. A

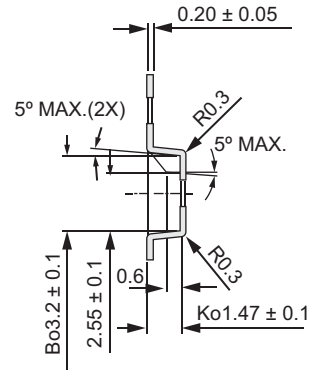
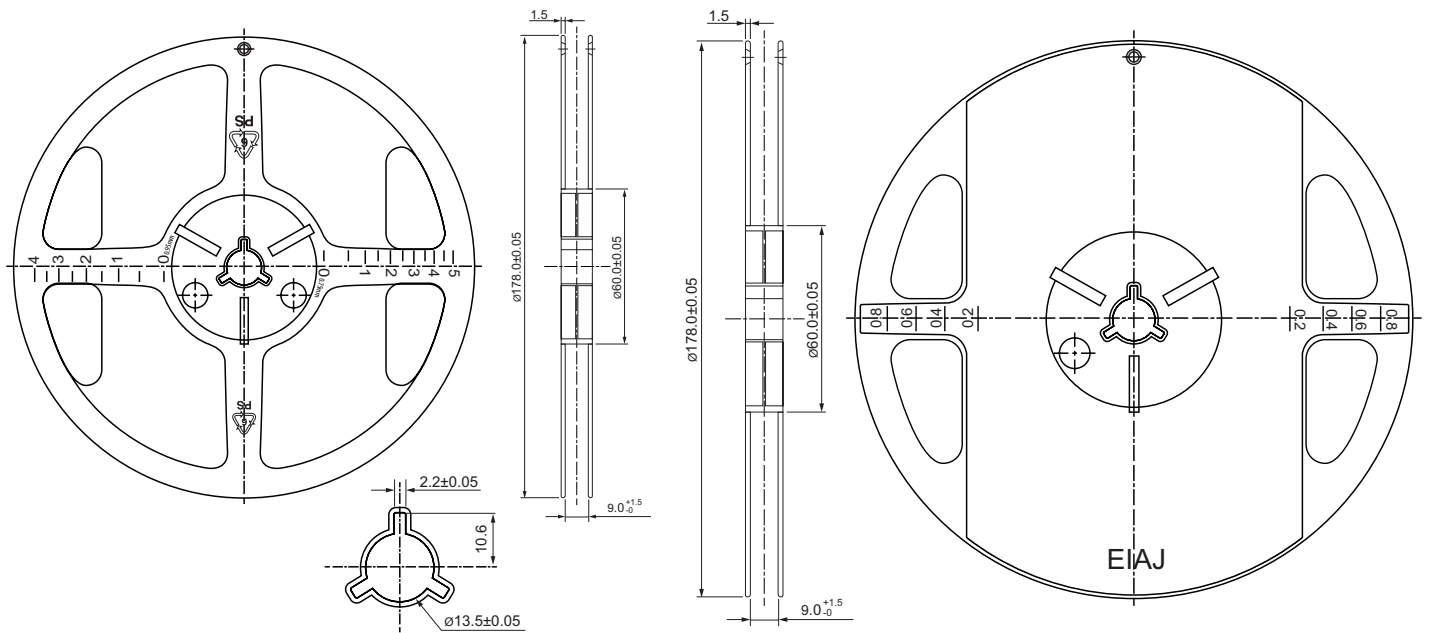
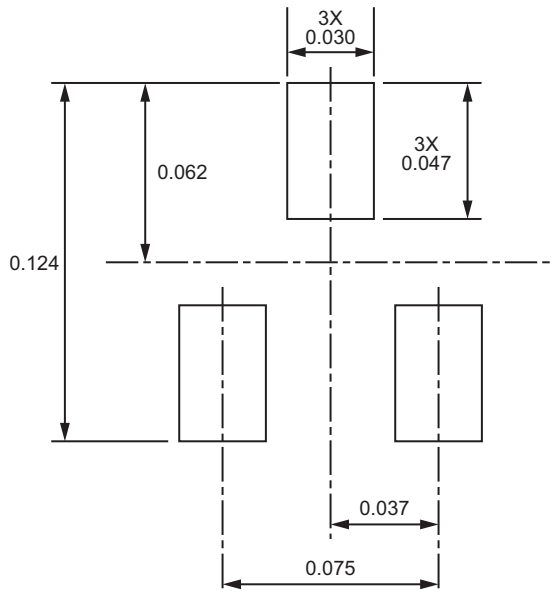

Fig. B



12 Suggested Solder Pad Layout



(Units in mm)

Notes:

1. Fully compatible with standard no-lead solder profile, 260 °C for 1 minute max (3 cycles max)
2. Profile shown as example. Users are advised to develop their own board-level profile
3. Temperature tolerance: +0 °C, as measured at any point on the package or leads
4. MSL rating of 1 compatible with J-STD-020 or equivalent.

13 Suggested Reflow Profile

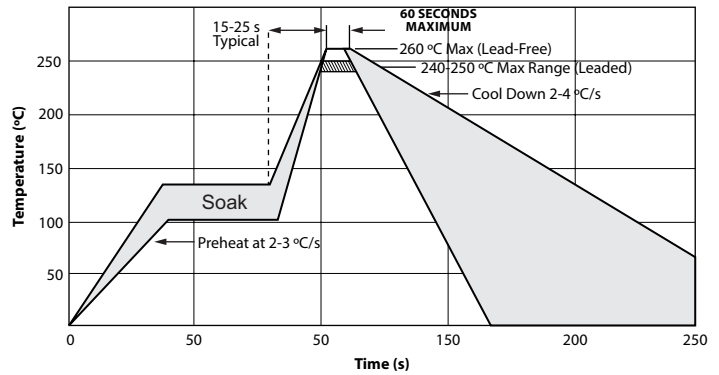

14 Application Circuits

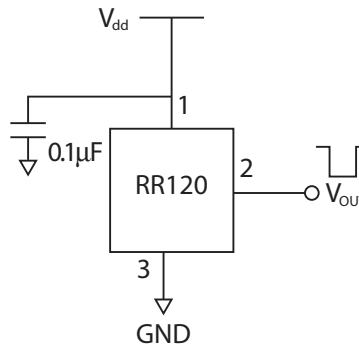

RR120 Digital Output Application Circuit

The output voltage on the RR120 is active low, meaning that while a sufficiently strong magnetic field is present, the output voltage is low. The output voltage can be connected to a digital I/O pin on a microcontroller. A decoupling capacitor between the supply voltage and ground is required with placement close to the magnetic sensor. A typical capacitor value of 0.1 µF will suffice.

15 Glossary of Terms

Hysteresis: Hysteresis refers to the difference between two points of interest for a particular device. For digital sensors and switches, it represents the difference between the operate sensitivity and the release sensitivity, expressed either as an absolute value ($B_{OP} - B_{RP}$) or the % difference $(B_{OP} - B_{RP})/B_{OP}$. For an analog sensor, the hysteresis is the difference between the “magnet approach curve” and the “magnet recede curve.”

Magnet Approach Curve: The magnet approach curve is the characteristic change in resistance of an analog TMR sensor as an applied magnetic field approaches the sensor, typically plotted as a function of the magnetic field strength.

Magnet Recede Curve: The magnet recede curve is the characteristic change in resistance of an analog TMR sensor as an applied magnetic field recedes from the sensor, typically plotted as a function of the magnetic field strength.

Magnetoresistance: Magnetoresistance is a phenomenon wherein the electrical resistance of certain materials changes when exposed to an externally-applied magnetic field.

Magnetic Transfer Curve: The magnetic transfer curve defines the characteristic behavior of an analog TMR sensor by combining both the magnet approach curve and the magnet receive curve together.

Magnetic Tunnel Junction: A magnetic tunnel junction is a thin film structure consisting of two magnetic layers separated by a thin insulator. Because the insulating layer is thin enough (typically a few nanometers), electrons can tunnel from one magnetic layer into the other.

Operate Sensitivity: The operate sensitivity defines the upper limit of the strength of an applied magnetic field that a digital TMR sensor or switch must operate.

Operate Time: The operate time is the difference, in time, between the application of a magnetic field and the output response of the device. In an analog sensor, the response is a change in output resistance. In a digital sensor, the response is a change in state of the electrical output.

Release Sensitivity: The release sensitivity defines the lower limit of the strength of an applied magnetic field that a digital TMR sensor or switch must release.

Release Time: The release time is the difference, in time, between the removal of an applied magnetic field and the output response of the device. In an analog sensor, the response is a change in output resistance. In a digital sensor, the response is a change in state of the electrical output.

Tunnel Magnetoresistance (TMR): Tunnel Magnetoresistance is the magnetoresistive effect that occurs in a magnetic tunnel junction.

16 Magnetic Sensitivity Maps

Magnetic sensitivity maps show the operate and release loci in three-dimensional space when a magnet is presented to a magnetically operated switch or sensor. The absolute operate and release distances between the magnet and the sensor will vary depending on the sensitivity of the switch and the strength of the magnet. However, the

shape and direction of the operate loci stay relatively constant except for cases where the magnet is physically much larger than the sensor. These plots were generated using a 2mm³ cubic shaped NdFeB N52 magnet with its North pole presented to the ground pin and a South pole presented to the opposite side.

RR120 Magnetic Sensitivity Pattern, perspective view

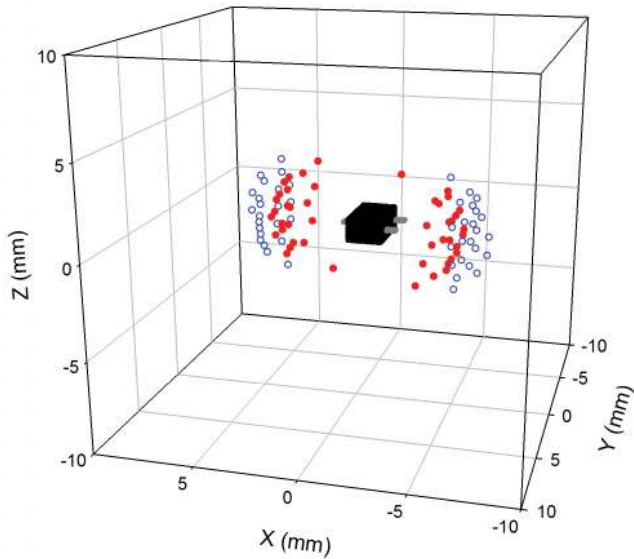

RR120 Magnetic Sensitivity Pattern, YZ plane

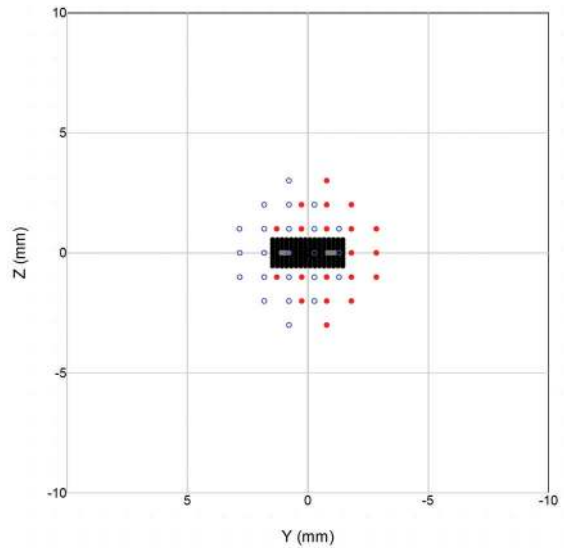

- Operate Points
- Release Points

RR120 Magnetic Sensitivity Pattern, XY plane

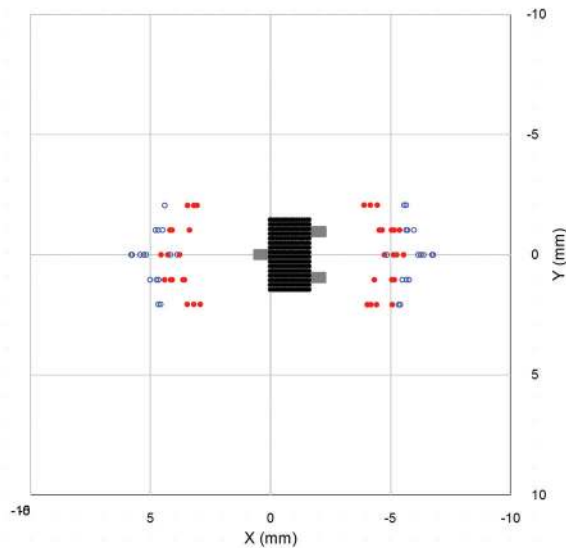

RR120 Magnetic Sensitivity Pattern, XZ plane

