

GX76474

4x64Gbit/s Linear Differential I/O Driver

The GX76474 is a low-power, high-performance, quad-channel linear driver chip. It is designed for 400G/600G optical integrated transmitter small-form factor (SFF) modules for metro and long-haul applications.

The GX76474 integrated quad lanes of driver with SPI circuitry for DC controls on a single die. Each channel of driver has 100Ω differential AC-coupled input and 60Ω differential interface with an open collector type output stage, and linear output voltage of 4.0V<sub>ppd</sub> suitable for Silicon Photonics modulator and multi-level modulations.

Applications

- 400/600Gbps 16QAM/64QAM advanced multi-level modulation systems
- High bandwidth SFF optical integrated modules

Features

- Data rate up to 64Gbps per channel for 400G/600G DP-mQAM applications
- > 40GHz Bandwidth
- > 10dB dynamic range of gain control
- 2.4W (typical) at linear 4.0V<sub>ppd</sub>
- AC-coupled 100Ω differential input/ open collector configuration at the output
- Ultra-low inter-channel cross-talk
- Peaking adjustment functionality
- Analog control for gain and output voltage setting, and analog monitor for peak detector and gain control monitor
- OIF compliant SPI digital interface integration

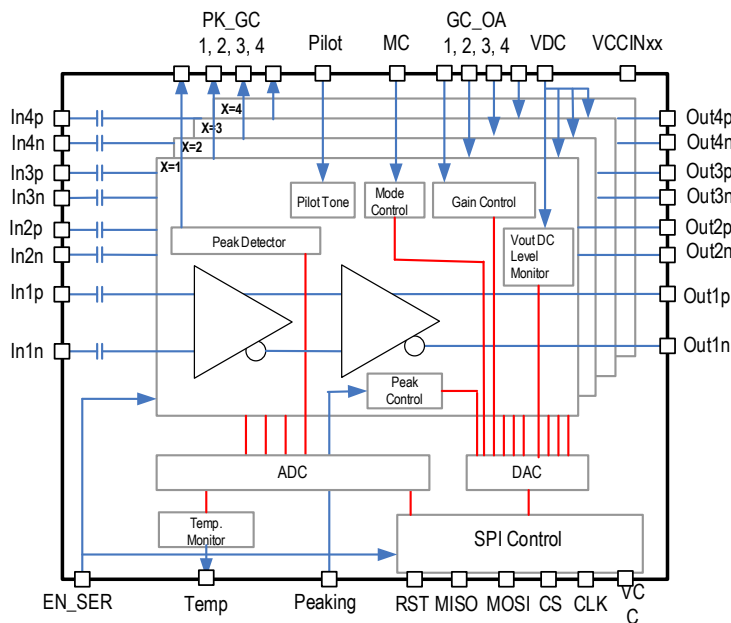

Figure 1. Block Diagram

## IMPORTANT NOTICE AND DISCLAIMER

RENESAS ELECTRONICS CORPORATION AND ITS SUBSIDIARIES (“RENESAS”) PROVIDES TECHNICAL SPECIFICATIONS AND RELIABILITY DATA (INCLUDING DATASHEETS), DESIGN RESOURCES (INCLUDING REFERENCE DESIGNS), APPLICATION OR OTHER DESIGN ADVICE, WEB TOOLS, SAFETY INFORMATION, AND OTHER RESOURCES “AS IS” AND WITH ALL FAULTS, AND DISCLAIMS ALL WARRANTIES, EXPRESS OR IMPLIED, INCLUDING, WITHOUT LIMITATION, ANY IMPLIED WARRANTIES OF MERCHANTABILITY, FITNESS FOR A PARTICULAR PURPOSE, OR NON-INFRINGEMENT OF THIRD PARTY INTELLECTUAL PROPERTY RIGHTS.

These resources are intended for developers skilled in the art designing with Renesas products. You are solely responsible for (1) selecting the appropriate products for your application, (2) designing, validating, and testing your application, and (3) ensuring your application meets applicable standards, and any other safety, security, or other requirements. These resources are subject to change without notice. Renesas grants you permission to use these resources only for development of an application that uses Renesas products. Other reproduction or use of these resources is strictly prohibited. No license is granted to any other Renesas intellectual property or to any third party intellectual property. Renesas disclaims responsibility for, and you will fully indemnify Renesas and its representatives against, any claims, damages, costs, losses, or liabilities arising out of your use of these resources. Renesas' products are provided only subject to Renesas' Terms and Conditions of Sale or other applicable terms agreed to in writing. No use of any Renesas resources expands or otherwise alters any applicable warranties or warranty disclaimers for these products.

(Disclaimer Rev.1.0 Mar 2020)

### Corporate Headquarters

TOYOSU FORESIA, 3-2-24 Toyosu,  
Koto-ku, Tokyo 135-0061, Japan  
[www.renesas.com](http://www.renesas.com)

### Contact Information

For further information on a product, technology, the most up-to-date version of a document, or your nearest sales office, please visit:  
[www.renesas.com/contact/](http://www.renesas.com/contact/)

### Trademarks

Renesas and the Renesas logo are trademarks of Renesas Electronics Corporation. All trademarks and registered trademarks are the property of their respective owners.