

Ha-VIS eCon 3000

Fast Ethernet Basic

PoE / PoE+ 24 V DC/DC



5 to 8 Ethernet Ports RJ45, SC and PoE/PoE+ with 24 V DC/DC converter
 Unmanaged Plug & Play Ethernet switches for DIN rail assembly in control cabinets
 Commercial Temp.: 0 °C ... +55 °C / Industrial Temp.: -40 °C ... +70 °C

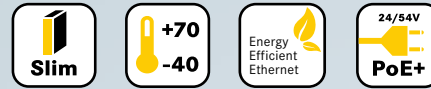

- Use of PoE+ with 24 V DC supply (isolated)
- Energy supply of up to 4 terminal devices via PoE+ (137 watts) according to IEEE 802.3at
- Fast Ethernet Non-Blocking Switch architecture according to IEEE 802.3
- Variants with industrial temperature range of -40°C ... +70 °C
- Surge protection and reverse polarity protection
- Minimum energy consumption due to Energy-Efficient Ethernet
- Optimised DIN rail bracket

Target markets

Machinery & Robotics	Automation technology	Industrial network infrastructures
Wind Energy Solar Energy	Transportation	Shipbuilding



General description

The Ha-VIS eCon 3000 Fast Ethernet PoE DC/DC family of unmanaged Ethernet switches is equipped with up to 8 Fast Ethernet ports and allow for cost-efficient and quick expansion and/or reconstruction of network infrastructures. The switches work as power sourcing equipment (PSE) and are capable of simultaneously providing the full PoE output of 34.2 watts on up to four ports. Exceeding the PoE+ standard, the switches are equipped with an integrated, galvanically isolated DC/DC voltage transformer. The

switches can be supplied with 24 VDC instead of the usually required 54 VDC. The selection includes various combinations of variants with RJ45 and fibre optic ports. Automatic detection of the transmission rate (auto-negotiation) and of the wiring of the twisted pair data cable (autopolarity and auto-MDI(X)) allow for simple plug & play. All variants are available with the temperature ranges „Industrial“ and „Commercial“.

Technical characteristics

Switch Features

Enclosures width	60 mm
Number of ports	5, 6, 7, 8
Switching technology	Store and Forward
Supported standards	IEEE 802.3
Frame Size	1522 bytes
MAC table size	1k entries
Packet buffer size	448 kbit
Non-blocking	Yes
Quality of service	Yes
Energy-Efficient Ethernet	Yes
PROFINET compatible	Yes
EthernetIP compatible	Yes

Voltage supply

Nominal voltage	24 VDC \equiv
Permissible voltage range	18 VDC ... 60 VDC \equiv
Surge protection	Yes
Reverse polarity proof	Yes
Starting current	1.60 A
Overcurrent protection at input	Yes (10 A)
Max. power consumption @ 24 VDC	138.5 W ... 140.2 W
Cross-section / Wire gauge	0.08 mm ² ... 2.5 mm ² (28 AWG ... 12 AWG)
Connection type	3-pole, pluggable screwed contact
Pinout	+ / - / \oplus
Supply circuit (acc. to 60950)	SELV (circuit breaker 10 A)

Ethernet Ports 10BASE-T_e / 100BASE-TX

Connection type	RJ45
Auto-negotiation	Yes
Auto-polarity	Yes
Auto-MDI(X)	Yes
Transfer conditions	Twisted Pair
Transfer speed	10 / 100 Mbit/s
Transfer length	100 m (twisted pair, Cat 5)

Ethernet Ports 100BASE-FX

Type of fibre	Multimode (MM)	Singlemode (SM)
Connection type	SC Duplex	
Transfer conditions	FO	
Wavelength	1310 nm	
Transfer speed	100 Mbit/s	
Transfer length	2 km	15 km
Output power	-20 dBm ... -14 dBm	-15 dBm ... -8 dBm
Input sensitivity	≤ -30 dBm	≤ -32 dBm

Ambient conditions

Commercial temperature range	0 °C ... +55 °C
Industrial temperature range	-40 °C ... +70 °C
Storage temperature range	-40 °C ... +85 °C
Relative humidity (operation)	0 % ... 95 % (not-condensing)
Relative humidity (storage and transport)	0 % ... 95 % (not-condensing)
Air pressure (operation)	2000 m (795 hPa)



HARTING Technology Group
 P.O.Box 1473, D-32325 Espelkamp
 Wilhelm-Harting-Straße 1, D-32325 Espelkamp, Germany

ICPN-Service@harting.com | Service hotline: +49 5772 47-9479
 Fax: +49 5772 47-495 | www.HARTING.com/de/ethernet-switches

Note: We reserve the right to make technical changes to the products and to the content of this document at any time without prior notification. The HARTING Technologiegruppe does not accept any responsibility for possible errors or incompleteness in this document. We reserve all the rights to this document and the topics and illustrations contained within it. Copying, disclosure to third parties or use of its content - even partially - is forbidden without the prior written consent of the HARTING Technologiegruppe.

PoE	PoE	PoE+
Number of PoE ports	4	
Standard	IEEE 802.3af / IEEE 802.3at	
PoE type	PSE	
Supported mode	Alternative A	
Supply voltage PSE	24 VDC ===	
Max. current consumption PSE	2,6 A	5,7 A
Max. current	375 mA	638 mA
Maximum output power PSE	15.4 W per port 61.6 W total	34.2 W per port 136.8 W total
Supported cabling	See 802.3at, section 33.1.4	
PoE pinout	Alternative A, MDI-X (1/2 = V-, 3/6 = V+)	

Enclosures	
Enclosures width	60 mm
Dimensions H x W x D (without pluggable screw contact and holding bracket)	142 mm x 60 mm x 107.5 mm
Weight	838 g ... 866 g
Type of installation	35 mm DIN rail acc. to EN 60 715
Material enclosures	Anodised aluminium / Powder-coated steel sheet
Protection degree (with plugged screw contact)	IP30
Protection class	III

Approvals
CE, FCC CFR 47 Part 15, cUL US 508 listed, ABB IIT
ECE - Approval mark (E1): see table technical characteristics

Status- und Diagnose-Anzeigen

Power („Pwr“) ϕ lights up green	Supply voltage is applied
Link/Activity („L/A“) off	No link
Link/Activity („L/A“) lights up green	Link is active
Link/Activity („L/A“) flashes green	Link is active and data is transferred
Link speed („Spd“) off	10 Mbit/s
Link speed („Spd“) lights up yellow	100 Mbit/s
PoE status ϕ off	PoE is inactive / low voltage
PoE status ϕ lights up blue	Voltage in PoE+ range
PoE status ϕ lights up red	Error

EMC and environmental conditions

EMC Interference immunity (EN 61000-6-1, 61 000-6-2 55024)
Electrostatic discharge (ESD) EN 61 000-4-2
Electromagnetic field EN 61 000-4-3
Rapid transients (burst) EN 61 000-4-4
Surge voltages EN 61 000-4-5
Conducted interference voltages EN 61 000-4-6

EMC Interference emission (EN 61000-6-4, EN 55 032, FCC CFR 47 Part 15)

Mechanical stability (EN 60721-3)
IEC 60068-2-6 Vibration
IEC 60068-2-6 Vibration resonance search
IEC 60068-2-27 Shock test

Included in delivery

- Pluggable screw contact for voltage supply
- Assembly instruction

Drawings

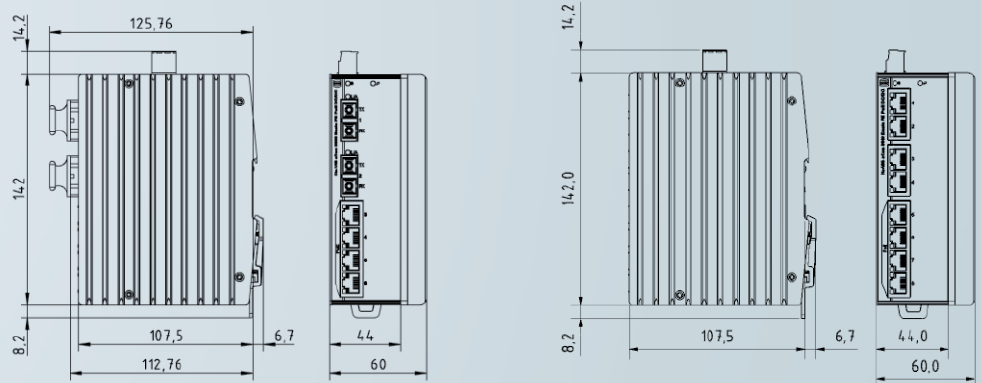

Technical characteristics / order information

Ports / order information

RJ45	SFP	SC	Enclosures width	Current consumption@ 24 VDC with PoE	MTBF in Mio. h	Commercial Temp.: 0 °C ... +55 °C		Industrial Temp.: -40 °C ... +70 °C	
						Switch	Part no.	Switch	Part no.
4	-	1x MM (2 km)	60 mm	5.81	0.82	Ha-VIS eCon 3041B-AD-PP	24 03 104 1130	Ha-VIS eCon 3041BT-AD-PP	24 03 104 1120
4	-	1x SM (15 km)	60 mm	5.81	0.82	Ha-VIS eCon 3041B-AF-PP	24 03 104 1230	Ha-VIS eCon 3041BT-AF-PP	24 03 104 1220
4	-	2x MM (2 km)	60 mm	5.84	0.81	Ha-VIS eCon 3042B-AD-PP	24 03 104 2130	Ha-VIS eCon 3042BT-AD-PP	24 03 104 2120
4	-	2x SM (15 km)	60 mm	5.84	0.81	Ha-VIS eCon 3042B-AF-PP	24 03 104 2230	Ha-VIS eCon 3042BT-AF-PP	24 03 104 2220
6	-	-	60 mm	5.77	0.85	Ha-VIS eCon 3060B-A-PP	24 03 106 0030 ¹	Ha-VIS eCon 3060BT-A-PP	24 03 106 0020 ¹
6	-	1x MM (2 km)	60 mm	5.82	0.80	Ha-VIS eCon 3061B-AD-PP	24 03 106 1130	Ha-VIS eCon 3061BT-AD-PP	24 03 106 1120
6	-	1x SM (15 km)	60 mm	5.82	0.80	Ha-VIS eCon 3061B-AF-PP	24 03 106 1230	Ha-VIS eCon 3061BT-AF-PP	24 03 106 1220
8	-	-	60 mm	5.78	0.83	Ha-VIS eCon 3080B-A-PP	24 03 108 0030 ¹	Ha-VIS eCon 3080BT-A-PP	24 03 108 0020 ¹

¹E1 Approval