

PRODUCT NUMBER

SEE TABLE

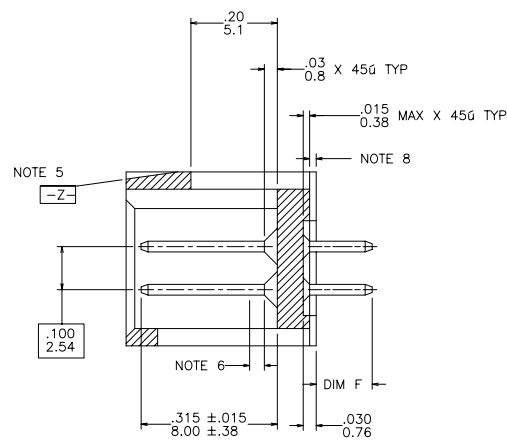
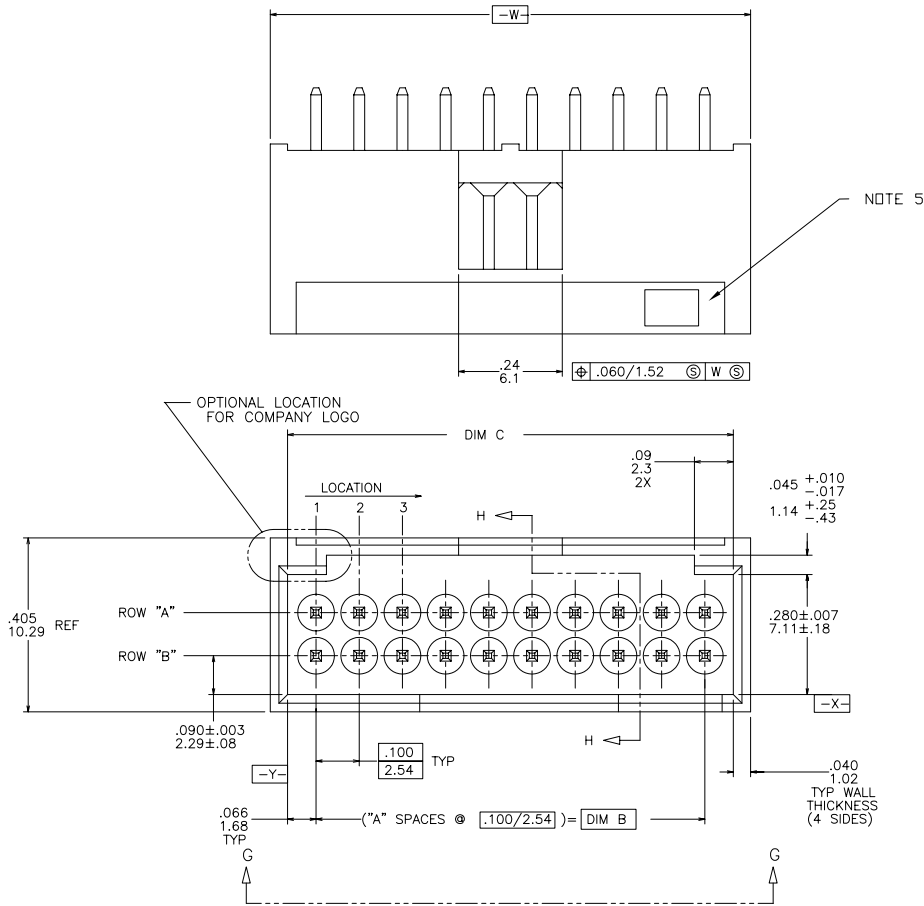

SECTION H-H

mat'l. code		surface		tolerance		projection		product family	
NOTE 1 & 3		ISO 1302 ✓		ISO 406 ISO 1101				HEADER	
ltr	ecn no	dr	date	tolerances unless otherwise specified		INCH/MM		title	
B	V00853	MRC	9/18/90	angles	linear	.XX±.01/XX±0.3		STRAIGHT HEADER FOR	
C	V70775	SAR	6/2/97			.XXX±.005/XX±0.13		ROUND WIRE RECEPTACLE	
D	V71034	EPK	9/24/97	0°±2'		.XXXX±.0020/XXX±0.051		scale 2.5:1	
E	V01576	MDF	7/5/00	dr	M. CORNMAN	9/18/90		dwg no	
F	M05-0167	ERE	7/23/05	engr	M. LEACH	9/18/90		sheet 1 of 6 size	
G	M07-0116	AGS	2/24/07	chr	M. LEACH	9/18/90		68664 A3	
H	N07-0150	MHT	8/01/07	appd	M. LEACH	9/18/90		type Product Customer Drawing	
sheet	revision	H	H	H	H	H	H		
index	sheet	1	2	3	4	5	6		



FCIconnect.com

Copyright FCI

PRODUCT NO.
SEE TABLE

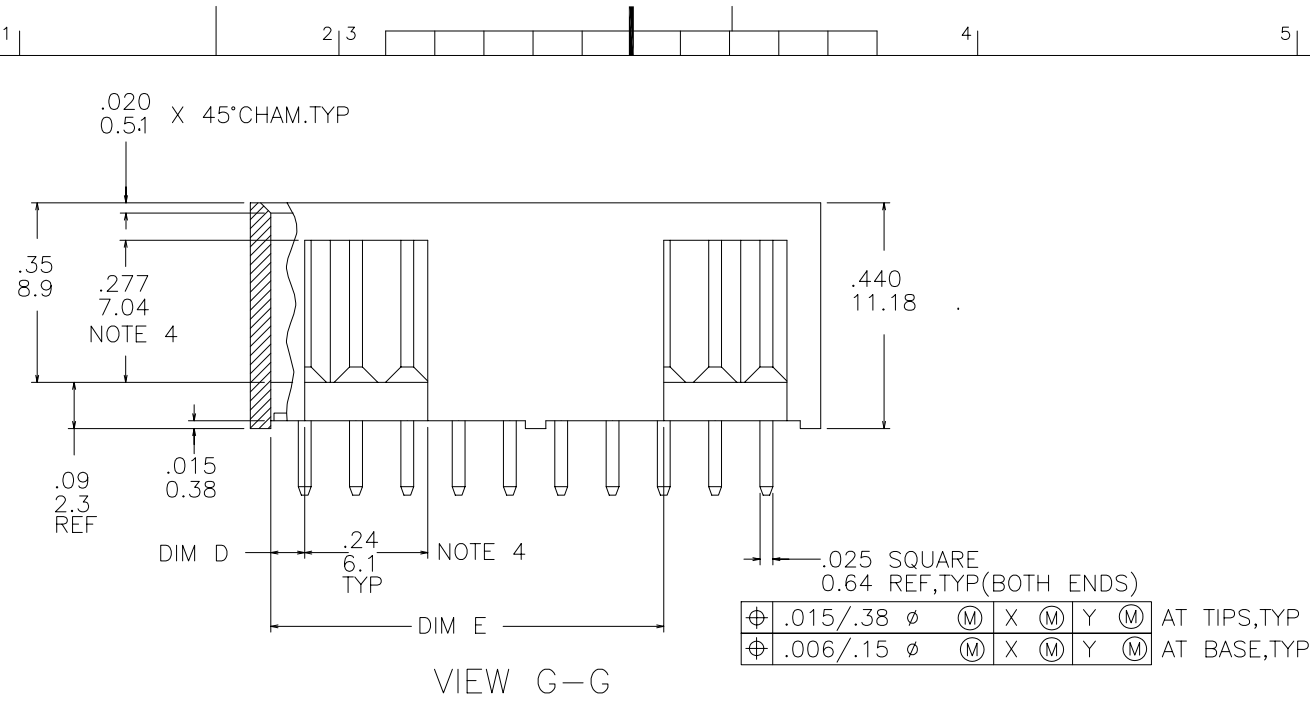

VIEW G-G

NOTES:

- ①. TERMINAL MATERIAL: 3/4 HARD PHOS. BRONZE ALLOY, UNS-C51000.
- ②. TERMINAL PLATING: 30u"/0.76u Au OR GXT OVER 50u"/1.27u Ni PLATING ON SWAGED TIPS MANUFACTURERS OPTION.
- ③. MOLDING MATERIAL: GLASS FILLED POLYESTER, FLAME RETARDANT PER UL-94V-0. COLOR: BLACK.
- ④. .020/.51 MAX FLASH AROUND ALL WINDOWS.
- ⑤. COMPANY LOGO MOLDED IN ON DATUM SURFACE -Z- APPROX. AS SHOWN.
- ⑥. .030/.76 MAX FLASH PERMISSIBLE ON THIS END OF PINS.
- ⑦. OTHER PLATINGS ARE AVAILABLE ON 68663, 68665, AND 68666.
- ⑧. .015/.38 MAX FLASH PERMISSIBLE ON THIS END OF PINS.
- ⑨. PLATING OPTIONS:
MAY BE EITHER GOLD OR GXT PLATED AT MANUFACTURER'S OPTION.
- ⑩. ADD "LF" SUFFIX AT THE END OF PART NUMBER FOR LEAD FREE OPTION
- ⑪. THIS PRODUCT MEETS EUROPEAN UNION DIRECTIVES AND OTHER COUNTRY REGULATION AS DESCRIBED IN GS-22-008.
- ⑫. THE HOUSING WILL WITHSTAND EXPOSURE TO 260°C PEAK TEMPERATURE FOR 15 SECONDS IN A WAVE SOLDER APPLICATION WITH A 1.5mm MINIMUM THICK CIRCUIT BOARD. SEE APPLICATION NOTES/PROCEDURES IF THEY ARE AVAILABLE.

FCIconnect.com
Copyright FCI

mat'l. code NOTE 1 & 3		surface ISO 1302 ✓		tolerance ISO 406 ISO 1101		projection ⊕		product family HEADER	
ltr	ecn	no	dr	date	tolerances unless otherwise specified		title		
H					angles	linear	INCH/MM		
					0°±2'	.XX±.01/XX±0.3 .XXX±.005/XXX±0.13 .XXX±.0020/XXX±0.051	STRAIGHT HEADER FOR ROUND WIRE RECEPTACLE		
					dr	M. CORNMAN	9/18/90	scale 2.5:1	
					enfr	M. LEACH	9/18/90	dwg no	
					chr	M. LEACH	9/18/90	sheet 2 of 6 size	
					appd	M. LEACH	9/18/90	68664 A3	
sheet index		revision sheet		type		Product Customer Drawing			

PRODUCT NO NOTE 10	NO OF POS	NO OF PINS	A SPACES	DIM B	DIM C ±.005 ±0.13	DIM D ±.005 ±0.13	DIM E ±.005 ±0.13	DIM F	POL. POS.	
									ROW A	ROW B
68664-001	6	6	2	.200/5.08	.332/8.43	.066/1.68	-----	.130/3.30		
-002	8	8	3	.300/7.62	.432/10.97	.066/1.68	-----			
-003	10	10	4	.400/10.16	.532/13.52	.166/4.22	-----			
-004	12	12	5	.500/12.70	.632/16.05	.166/4.22	-----			
-005	14	14	6	.600/15.24	.732/18.59	.266/6.76	-----			
-006	16	16	7	.700/17.78	.832/21.13	.266/6.76	-----			
-007	18	18	8	.800/20.32	.932/23.67	.366/9.30	-----			
-008	20	20	9	.900/22.86	1.032/26.21	.066/1.68	.766/19.46			
-009	22	22	10	1.000/25.40	1.132/28.75		.866/22.00			
-010	24	24	11	1.100/27.94	1.232/31.29		.966/24.54			
-011	26	26	12	1.200/30.48	1.332/33.83		1.066/27.08			
-012	28	28	13	1.300/33.02	1.432/36.37		1.166/29.62			
-013	30	30	14	1.400/35.56	1.532/38.91		1.266/32.16			
-014	32	32	15	1.500/38.10	1.632/41.45		1.366/34.70			
-015	34	34	16	1.600/40.64	1.732/43.99		1.466/37.24			
-016	36	36	17	1.700/43.18	1.832/46.53		1.566/39.78			
-017	38	38	18	1.800/45.72	1.932/49.07		1.666/42.32			
-018	40	40	19	1.900/48.26	2.032/51.61		1.766/44.86			
-019	42	42	20	2.000/50.80	2.132/54.15		1.866/47.40			
-020	44	44	21	2.100/53.34	2.232/56.69		1.966/49.94			
-021	46	46	22	2.200/55.88	2.332/59.23		2.066/52.48			
-022	48	48	23	2.300/58.42	2.432/61.77		2.166/55.02			
-023	50	50	24	2.400/60.96	2.532/64.31		2.266/57.56			
-024	52	52	25	2.500/63.50	2.632/66.85		2.366/60.10			
-025	54	54	26	2.600/66.04	2.732/69.39		2.466/62.64			
-026	56	56	27	2.700/68.58	2.832/71.93		2.566/65.18			
-027	58	58	28	2.800/71.12	2.932/74.47		2.666/67.72			
-028	60	60	29	2.900/73.66	3.032/77.01		2.766/70.26			
-029	62	62	30	3.000/76.20	3.132/79.55		2.866/72.80			
-030	64	64	31	3.100/78.74	3.232/82.09		2.966/75.34			
-031	66	66	32	3.200/81.28	3.332/84.63		3.066/77.88			
-032	68	68	33	3.300/83.82	3.432/87.17		3.166/80.42			
-033	70	70	34	3.400/86.36	3.532/89.71		3.266/82.96			
68664-034	72	72	35	3.500/88.90	3.632/92.25	.066/1.68	3.366/85.50	.130/3.30		



FCIconnect.com

Copyright FCI

mat'l. code NOTE 1 & 3		surface ISO 1302 ✓		tolerance ISO 406 ISO 1101		projection ⊕		product family HEADER	
ltr		ecn no		date		tolerances unless otherwise specified		title	
H						.XX±.01/XX±0.3		INCH/MM	
						.XXX±.005/XX±0.13		STRAIGHT HEADER FOR	
						.XXXX±.0020/XXX±0.051		ROUND WIRE RECEPTACLE	
						0'±2'		scale 2.5:1	
				dr		M. CORNMAN 9/18/90		dwg no	
				enfr		M. LEACH 9/18/90		sheet 3 of 6 size	
				chr		M. LEACH 9/18/90		68664 A3	
				appd		M. LEACH 9/18/90		type Product Customer Drawing	
sheet index		revision sheet							

form: A3 1 2 3 4 5 6

PRODUCT NO NOTE 10	NO OF POS	NO OF PINS	A SPACES	DIM B	DIM C ± 0.005 ± 0.13	DIM D ± 0.005 ± 0.13	DIM E ± 0.005 ± 0.13	DIM F	POL. POS.	
									ROW A	ROW B
68664-035	6	6	2	.200/5.08	.332/8.43	.066/1.68	-----	.155/3.94		
-036	8	8	3	.300/7.62	.432/10.97	.066/1.68	-----			
-037	10	10	4	.400/10.16	.532/13.52	.166/4.22	-----			
-038	12	12	5	.500/12.70	.632/16.05	.166/4.22	-----			
-039	14	14	6	.600/15.24	.732/18.59	.266/6.76	-----			
-040	16	16	7	.700/17.78	.832/21.13	.266/6.76	-----			
-041	18	18	8	.800/20.32	.932/23.67	.366/9.30	-----			
-042	20	20	9	.900/22.86	1.032/26.21	.066/1.68	.766/19.46			
-043	22	22	10	1.000/25.40	1.132/28.75		.866/22.00			
-044	24	24	11	1.100/27.94	1.232/31.29		.966/24.54			
-045	26	26	12	1.200/30.48	1.332/33.83		1.066/27.08			
-046	28	28	13	1.300/33.02	1.432/36.37		1.166/29.62			
-047	30	30	14	1.400/35.56	1.532/38.91		1.266/32.16			
-048	32	32	15	1.500/38.10	1.632/41.45		1.366/34.70			
-049	34	34	16	1.600/40.64	1.732/43.99		1.466/37.24			
-050	36	36	17	1.700/43.18	1.832/46.53		1.566/39.78			
-051	38	38	18	1.800/45.72	1.932/49.07		1.666/42.32			
-052	40	40	19	1.900/48.26	2.032/51.61		1.766/44.86			
-053	42	42	20	2.000/50.80	2.132/54.15		1.866/47.40			
-054	44	44	21	2.100/53.34	2.232/56.69		1.966/49.94			
-055	46	46	22	2.200/55.88	2.332/59.23		2.066/52.48			
-056	48	48	23	2.300/58.42	2.432/61.77		2.166/55.02			
-057	50	50	24	2.400/60.96	2.532/64.31		2.266/57.56			
-058	52	52	25	2.500/63.50	2.632/66.85		2.366/60.10			
-059	54	54	26	2.600/66.04	2.732/69.39		2.466/62.64			
-060	56	56	27	2.700/68.58	2.832/71.93		2.566/65.18			
-061	58	58	28	2.800/71.12	2.932/74.47		2.666/67.72			
-062	60	60	29	2.900/73.66	3.032/77.01		2.766/70.26			
-063	62	62	30	3.000/76.20	3.132/79.55		2.866/72.80			
-064	64	64	31	3.100/78.74	3.232/82.09		2.966/75.34			
-065	66	66	32	3.200/81.28	3.332/84.63		3.066/77.88			
-066	68	68	33	3.300/83.82	3.432/87.17		3.166/80.42			
-067	70	70	34	3.400/86.36	3.532/89.71		3.266/82.96			
68664-068	72	72	35	3.500/88.90	3.632/92.25	.066/1.68	3.366/85.50	.155/3.94		



FCIconnect.com

Copyright FCI

mat'l. code NOTE 1 & 3		surface ISO 1302 <input checked="" type="checkbox"/>		tolerance ISO 406 ISO 1101		projection 		product family HEADER	
ltr		ecn no		dr		date		tolerances unless otherwise specified	
H								.XX±.01/.X±0.3	
				angles		linear		.XXX±.005/.XX±0.13	
				0'±2'				.XXXX±.0020/.XXX±0.051	
				dr		M. CORNMANN		9/18/90	
				enfr		M. LEACH		9/18/90	
				chr		M. LEACH		9/18/90	
				appd		M. LEACH		9/18/90	
sheet index		revision sheet							



title
STRAIGHT HEADER FOR
ROUND WIRE RECEPTACLE

dwg no
68664

sheet 4 of 6 size
A3

type Product Customer Drawing

PRODUCT NO NOTE 10	NO OF POS	NO OF PINS	A SPACES	DIM B	DIM C ±.005 ±0.13	DIM D ±.005 ±0.13	DIM E ±.005 ±0.13	DIM F	POL. POS.	
									ROW A	ROW B
68664-069	6	6	2	.200/5.08	.332/8.43	.066/1.68	-----	.200/5.08		
-070	8	8	3	.300/7.62	.432/10.97	.066/1.68	-----			
-071	10	10	4	.400/10.16	.532/13.52	.166/4.22	-----			
-072	12	12	5	.500/12.70	.632/16.05	.166/4.22	-----			
-073	14	14	6	.600/15.24	.732/18.59	.266/6.76	-----			
-074	16	16	7	.700/17.78	.832/21.13	.266/6.76	-----			
-075	18	18	8	.800/20.32	.932/23.67	.366/9.30	-----			
-076	20	20	9	.900/22.86	1.032/26.21	.066/1.68	.766/19.46			
-077	22	22	10	1.000/25.40	1.132/28.75		.866/22.00			
-078	24	24	11	1.100/27.94	1.232/31.29		.966/24.54			
-079	26	26	12	1.200/30.48	1.332/33.83		1.066/27.08			
-080	28	28	13	1.300/33.02	1.432/36.37		1.166/29.62			
-081	30	30	14	1.400/35.56	1.532/38.91		1.266/32.16			
-082	32	32	15	1.500/38.10	1.632/41.45		1.366/34.70			
-083	34	34	16	1.600/40.64	1.732/43.99		1.466/37.24			
-084	36	36	17	1.700/43.18	1.832/46.53		1.566/39.78			
-085	38	38	18	1.800/45.72	1.932/49.07		1.666/42.32			
-086	40	40	19	1.900/48.26	2.032/51.61		1.766/44.86			
-087	42	42	20	2.000/50.80	2.132/54.15		1.866/47.40			
-088	44	44	21	2.100/53.34	2.232/56.69		1.966/49.94			
-089	46	46	22	2.200/55.88	2.332/59.23		2.066/52.48			
-090	48	48	23	2.300/58.42	2.432/61.77		2.166/55.02			
-091	50	50	24	2.400/60.96	2.532/64.31		2.266/57.56			
-092	52	52	25	2.500/63.50	2.632/66.85		2.366/60.10			
-093	54	54	26	2.600/66.04	2.732/69.39		2.466/62.64			
-094	56	56	27	2.700/68.58	2.832/71.93		2.566/65.18			
-095	58	58	28	2.800/71.12	2.932/74.47		2.666/67.72			
-096	60	60	29	2.900/73.66	3.032/77.01		2.766/70.26			
-097	62	62	30	3.000/76.20	3.132/79.55		2.866/72.80			
-098	64	64	31	3.100/78.74	3.232/82.09		2.966/75.34			
-099	66	66	32	3.200/81.28	3.332/84.63		3.066/77.88			
-100	68	68	33	3.300/83.82	3.432/87.17		3.166/80.42			
-101	70	70	34	3.400/86.36	3.532/89.71		3.266/82.96			
68664-102	72	72	35	3.500/88.90	3.632/92.25	.066/1.68	3.366/85.50	.200/5.08		



Copyright FCI

mat'l. code NOTE 1 & 3		surface ISO 1302 <input checked="" type="checkbox"/>	tolerance ISO 406 ISO 1101	projection 	product family HEADER
ltr	ecn	no	dr	date	tolerances unless otherwise specified
H					angles linear .XX±.01/XX±0.3 .XXX±.005/XX±0.13 .XXXX±.0020/XXX±0.051
					0'±2'
			dr	M. CORNMAN	9/18/90
			enfr	M. LEACH	9/18/90
			chr	M. LEACH	9/18/90
			appd	M. LEACH	9/18/90
sheet index	revision sheet				



title
STRAIGHT HEADER FOR
ROUND WIRE RECEPTACLE

scale 2.5:1

dwg no 68664 sheet 5 of 6 size A3

type Product Customer Drawing

PRODUCT NO NOTE 10	NO. OF POS	NO. OF PINS	A SPACES	DIM B	DIM C ±.005 ±0.13	DIM D ±.005 ±0.13	DIM E ±.005 ±0.13	DIM F	POL. POS.	
									ROW A	ROW B
68664-103	6	6	2	.200/5.08	.332/8.43	.066/1.68	-----	.380/9.65	-----	-----
-104	8	8	3	.300/7.62	.432/10.97	.066/1.68	-----	.380/9.65	↑	↑
-105	12	12	5	.500/12.70	.632/16.05	.166/4.22	-----	.380/9.65	↑	↑
-106	16	16	7	.700/17.78	.832/21.13	.266/6.76	-----	.380/9.65	↑	↑
-107	20	20	9	.900/22.86	1.032/26.21	.066/1.68	.766/19.46	.380/9.65	-----	-----
68664-108	14	13	6	.600/15.24	.732/18.59	.266/6.76	-----	.130/3.30	1	-----
68664-132	32	32	15	1.500/38.10	1.632/41.45	.066/1.68	1.366/34.70	.325/8.26	-----	-----



Copyright FCJ

mat'l. code NOTE 1 & 3		surface ISO 1302 ✓		tolerance ISO 406 ISO 1101		projection ⊕		product family HEADER	
ltr	ecn	no	dr	date	tolerances unless otherwise specified		title		
H					angles	linear	INCH/MM		
					0°±2'	.XX±.01/X±0.3 .XXX±.005/XX±0.13 .XXXX±.0020/XXX±0.051	scale 2.5:1		
			dr	M. CORNMAN	9/18/90	FCJ		dwg no	
			enfr	M. LEACH	9/18/90			sheet 6 of 6 size	
			chr	M. LEACH	9/18/90			68664 A3	
			appd	M. LEACH	9/18/90			type Product Customer Drawing	
sheet index	revision sheet								