

REV.	DATE	ECR NO.	DESCRIPTION
NC	12/14/00	XXXXXX	INITIAL RELEASE
A	10/19/08	XXXXXX	UPDATE DRAWING FORMAT
B	09/06/13	2524	ADD MISSING ITEMS TO B.O.M., CHANGE FERRULE, CORRECT CONTACT O.D., UPDATE DRAWING FORMAT

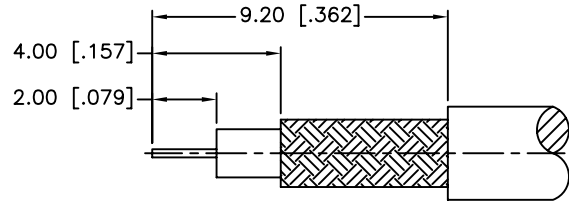

RECOMMENDED
CABLE STRIPPING DIM'S

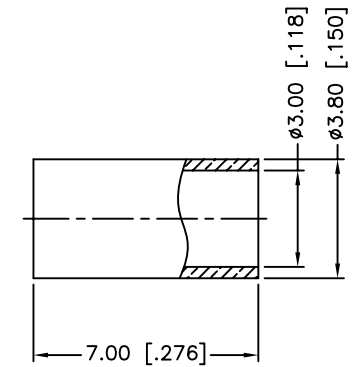
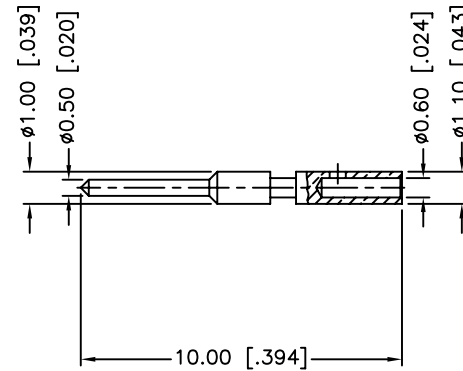
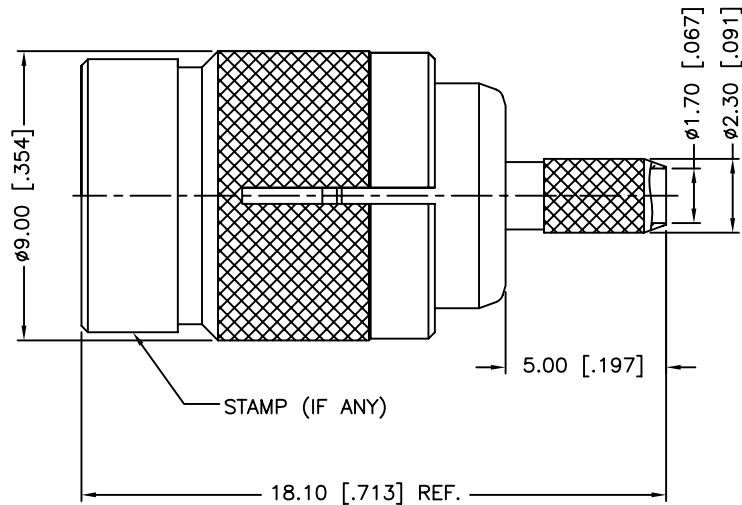

1. IMPEDANCE: 50 OHM
2. FREQUENCY RANGE: 0-4 GHZ
3. DIELECTRIC WITHSTANDING VOLTAGE: 750 VRMS, MIN.
4. DURABILITY: 500 CYCLES MIN.
5. TEMPERATURE RANGE: -40°C TO +155°C
6. CRIMPED FERRULE
HEX. CRIMP SIZE .128"
7. CONTACT PIN TO SOLDER

QTY	DESCRIPTION	MATERIAL	FINISH
1	FERRULE	COPPER	NICKEL
1	CONTACT PIN	BRASS	GOLD
1	OUTER CONTACT	PHOSPHOR BRONZE	GOLD
1	INSULATOR	PTFE	NATURAL
1	BARREL	BRASS	NICKEL
1	SPRING	SUS 301H	PASSIVATED
1	BODY	BRASS	NICKEL
1	SHELL	BRASS	NICKEL

UNLESS OTHERWISE SPECIFIED DIMENSIONS ARE IN MILLIMETERS. DIMENSIONS IN [] ARE IN INCHES AND FOR CUSTOMER REFERENCE ONLY.
UNLESS OTHERWISE SPECIFIED
TOLERANCES FOR MILLIMETERS ARE:
<0.5 ± 0.05mm
0.5 - 6mm ± 0.10mm
6 - 30mm ± 0.20mm
30 - 120mm ± 0.30mm
ANGLES ± 1°
UNLESS OTHERWISE SPECIFIED
TOLERANCES FOR INCHES ARE:
<.020 ± 0.002"
.020 - .236 ± 0.004"
.236 - 1.180 ± 0.007"
1.180 - 4.724 ± 0.012"
ANGLES ± 1°
DO NOT SCALE DRAWING

APPROVALS	DATE
DRAWN M.ZHANG	09/06/13
CHECKED	
ISSUED	
SHEET 1 OF 1	
CAD FILE C:/CONNEX/282103.DWG	

Amphenol Connex			
PART DESCRIPTION 1.0/2.3 CRIMP PLUG (FOR RG-174/U,188A/U,316/U CABLE)			
PART NO. 282103			
DWG. NO.	282103.DWG	REV.	B
SIZE	A	SCALE	NA