

LoPy 1.0

With LoRa, Wifi and BLE, the LoPy is the only triple bearer MicroPython enabled micro controller on the market today – the perfect enterprise grade IoT platform for your connected Things. With the latest Espressif chipset the LoPy offers a perfect combination of power, friendliness and flexibility. Create and connect your things everywhere. Fast.

LoPy Features

- Powerful CPU, BLE and state of the art WiFi radio. 1KM Wifi Range
- Can also double up as a Nano LoRa gateway
- MicroPython enabled
- Fits in a standard breadboard (with headers)
- Ultra-low power usage: a fraction compared to other connected micro controllers

Processing

- Espressif ESP32 chipset
- Dual processor + WiFi radio System on Chip.
- Network processor handles the WiFi connectivity and the IPv6 stack.
- Main processor is entirely free to run the user application.
- An extra ULP-coprocessor that can monitor GPIOs, the ADC channels and control most of the internal peripherals during deep-sleep mode while only consuming 25uA.

Operating Frequencies

- 868 MHz (Europe) at +14dBm maximum
- 915 MHz (North and South America, Australia and New Zealand) at +20dBm maximum

Range Specification

- Node range: Up to 40km
- Nano-Gateway: Up to 22km
- Nano-Gateway Capacity: Up to 100 nodes

Use the Pymakr IDE

Super easy code editor to write your Python scripts

Quick Verification

For easy and fast debugging use the interactive shell that is accessible through telnet or one of the serial ports

Easy Upload

Upload your scripts, and any other files you want to the LoPy via the FTP server

Locally or remotely

Reset the LoPy (you can do it locally, or remotely via Telnet)

Mechanical

Size: 55mm x 20mm x 3.5mm

Operating temperature:
-40 to 85 degrees celsius

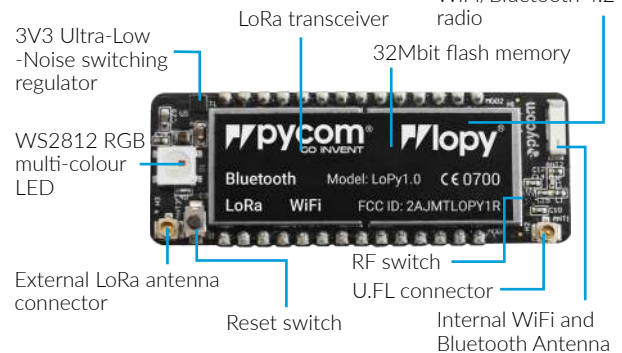

Interfaces

- 2 x UART, 2 x SPI, I2C, I2S, micro SD card
- Analog channels: 8x12 bit ADCs
- Timers: 4x16 bit with PWM and input capture
- DMA on all peripherals
- GPIO: Up to 24

Security & Certifications

- SSL/TLS support
- WPA Enterprise security
- FCC - 2AJMTWIPY2R
- CE 0700

Memory

- RAM: 512KB
- External flash 4MB
- Hardware floating point acceleration
- Python multi-threading

Power

- Input: 3.3V - 5.5V
- 3v3 output capable of sourcing up to 400mA
- WiFi: 12mA in active mode, 5uA in standby
- Lora: 15mA in active mode, 10uA in standby

LoRa Specification

- Semtech LoRa transceiver SX1272
- LoRaWAN stack
- Class A and C devices

With dozens of ready to use templates and libraries soon to be available on the Pycom Exchange, developing a new IoT solution is now easier and faster.

EU Regulatory Conformance

Hereby, Pycom Ltd declares that this device is in compliance with the essential requirements and other relevant provisions of Directive 1999/5/EC.

Federal Communication Commission Interference Statement

This device complies with Part 15 of the FCC Rules. Operation is subject to the following two conditions:

- (1) This device may not cause harmful interference.
- (2) This device must accept any interference received, including interference that may cause undesired operation.

CAUTION: Changes or modifications not expressly approved by the party responsible for compliance could void the user's authority to operate the equipment.

NOTE: This equipment has been tested and found to comply with the limits for a Class B digital device, pursuant to Part 15 of the FCC Rules. These limits are designed to provide reasonable protection against harmful interference in a residential installation. This equipment generates uses and can radiate radio frequency energy and, if not installed and used in accordance with the instructions, may cause harmful interference to radio communications. However, there is no guarantee that interference will not occur in a particular installation. If this equipment does cause harmful interference to radio or television reception, which can be determined by turning the equipment off and on, the user is encouraged to try to correct the interference by one or more of the following measures:

- Reorient or relocate the receiving antenna.
- Increase the separation between the equipment and receiver.
- Connect the equipment into an outlet on a circuit different from that to which the receiver is connected.
- Consult the dealer or an experienced radio/TV technician for help.

RF Warning Statement

To comply with FCC RF exposure compliance requirements, the antennas used for this transmitter must be installed to provide a separation distance of at least 20 cm from all persons and must not be co-located or operating in conjunction with any other antenna or transmitter.

This device is intended only for OEM integrators under the following conditions:

- 1) The antenna must be installed such that 20 cm is maintained between the antenna and users, and
- 2) The transmitter module may not be co-located with any other transmitter or antenna.

As long as two conditions above are met, further transmitter test will not be required.

However, the OEM integrator is still responsible for testing their end-product for any additional compliance requirements required with this module installed. To ensure compliance with all non-transmitter functions the host manufacturer is responsible

for ensuring compliance with the module(s) installed and fully operational. For example, if a host was previously authorized as an unintentional radiator under the Declaration of Conformity procedure without a transmitter certified module and a module is added, the host manufacturer is responsible for ensuring that the after the module is installed and operational the host continues to be compliant with the Part 15B unintentional radiator requirements

The module is limited to OEM installation ONLY. The module is limited to installation in mobile or fixed application. We hereby acknowledge our responsibility to provide guidance to the host manufacturer in the event that they require assistance for ensuring compliance with the Part 15 Subpart B requirements.

IMPORTANT NOTE: In the event that these conditions cannot be met (for example certain laptop configurations or co-location with another transmitter), then the FCC authorization is no longer considered valid and the FCC ID cannot be used on the final product. In these circumstances, the OEM integrator will be responsible for reevaluating the end product(including the transmitter) and obtaining a separate FCC authorization.

End Product Labeling

This transmitter module is authorized only for use in device where the antenna may be installed such that 20 cm may be maintained between the antenna and users. The final end product must be labeled in a visible area with the following: "Contains FCC ID: 2AJMTLOPY1R". The grantee's FCC ID can be used only when all FCC compliance requirements are met.

The following FCC part 15.19 statement has to also be available on the label:

This device complies with Part 15 of FCC rules. Operation is subject to the following two conditions:

- (1) this device may not cause harmful interference and
- (2) this device must accept any interference received, including interference that may cause undesired operation.

Manual Information to the End User

The OEM integrator has to be aware not to provide information to the end user regarding how to install or remove this RF module in the user's manual of the end product which integrates this module.

In the user manual of the end product, the end user has to be informed that the equipment complies with FCC radio-frequency exposure guidelines set forth for an uncontrolled environment.

The end user has to also be informed that any changes or modifications not expressly approved by the manufacturer could void the user's authority to operate this equipment.

The end user manual shall include all required regulatory information/warning as show in this manual.

The maximum operating ambient temperature of the equipment declared by the manufacturer is
-20~+85C

Receiver category 3