



Built-in EVENT RECORDER FUNCTION SERIAL-INTERFACE REAL TIME CLOCK MODULE

RX-5412SF

- Built in frequency adjusted 32.768 kHz crystal unit.
- Interface Type : 4-wire serial interface
- Operating voltage range : 2.5 V to 5.5 V
- Wide Timekeeper voltage range : 1.4 V to 5.5 V
- Low backup current : 0.5 μ A / 3 V (Typ.)
- Built-in SRAM : Built-in 2048 bit (8 bit \times 256)
- The various functions include full calendar, alarm, timer, event record, watch dog timer, automatic power switching function.



Product Number (Please contact us)
X1B000082xxxx00



Actual size

**NEW**

Block diagram

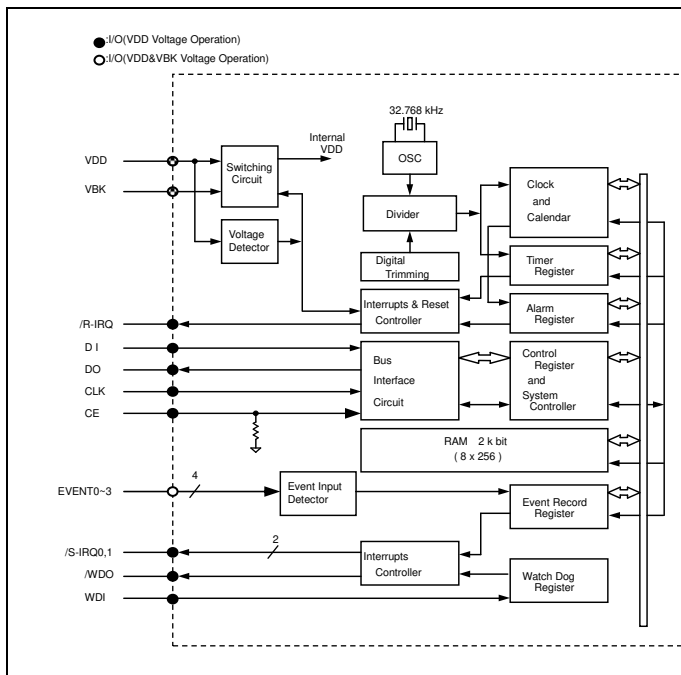

Overview

- **Event recorder function**
 - 4 input ports are available for event recorder request.
 - Event recorder data are recorded in inside memory according to user setting.
- **Power switching circuit**
 - When VDD voltage are down, real time clock module power source are switched to VBAT from VDD.
- **Built-in SRAM (256 bytes)**
 - Available built in SRAM for users memory and event recorder memory.
- **Watch dog timer function**
 - Watch dog time, it can set from 1.95 ms to 468.75 ms
- **Voltage drop detection**
 - When real time clock module return from backup mode, this function indicate The reliability of real time clock module data.
- **Periodic timer function**
 - In a timer period, it can set from 1/4096 seconds to 4095 minutes.
- **Alarm function**
 - Alarm by combination of day of week, day, hours, and minutes.

Pin Function

Signal name	Pin No.	I / O	Function	Signal name	Pin No.	I / O	Function
Vss	1	-	GND	(Vss)	24	-	
EVENT0	2	Input	Event input	(Vss)	23	-	
EVENT1	3	Input	Event input	(Vss)	22	-	
VBK	4	-	Backup power supply	(Vss)	21	-	
EVENT2	5	Input	Event input	(Vss)	20	-	
(Vss)	6	-		(Vss)	19	-	
EVENT3	7	Input	Event input	/S-IRQ1	18	Output	Event record interrupt output (open drain)
CE	8	Input	Chip enabled input	/S-IRQ0	17	Output	Event record interrupt output (open drain)
CLK	9	Input	Clock input pin for serial data transmission	WDI	16	Input	Watch dog input (open drain)
DO	10	Output	Data output pin for serial data transmission	/WDO	15	Output	Watch dog output (open drain)
DI	11	Input	Data input pin for serial data transmission	N.C.	14	-	-
/R-IRQ	12	Output	RTC function interrupt output (open drain)	V _{DD}	13	-	Power supply

External dimensions

(Unit:mm)

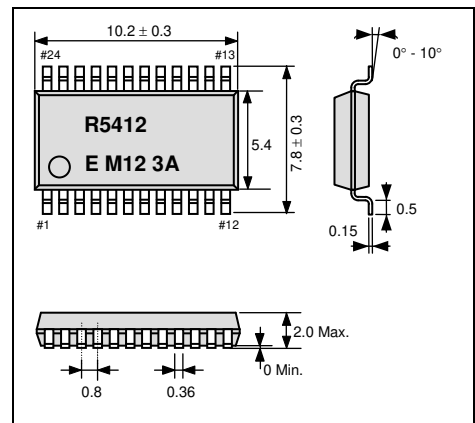

Specifications (characteristics)

*Refer to application manual for details.

Electrical Characteristics

Item	Symbol	Condition	Min.	Typ.	Max.	Unit
Power voltage	V _{DD}	-	2.5	3.0	5.5	V
Clock voltage	V _{CLK}	-	1.4	3.0	5.5	V
Operating temperature	T _{OPR}	-	-40	+25	+85	°C
Frequency tolerance	$\Delta f / f$	T _a = +25 °C, V _{DD} = 3.0 V		5 ± 23 *		$\times 10^{-6}$
Current Consumption	I _{DD1}	Back up operation, CE = GND, /IRQ = OFF		0.5	1.0	μ A
	I _{DD2}			0.5	1.0	

*Equivalent to 1 minute of monthly deviation.