VOLTAGE REGULATOR

NO. EA-022-120404

OUTLINE

The Rx5RL Series are CMOS-based voltage regulator ICs with high accuracy output voltage and ultra-low quiescent current. Each of these ICs consists of a voltage reference unit, an error amplifier, a driver transistor, and resistors for setting output voltage. The output voltage is fixed with high accuracy.

Three types of packages, TO-92 (**Discontinued**), SOT-89 (Mini-power Mold), SOT-23-5 (Mini-mold), are available.

FEATURES

- Supply Current Typ. 1.1 μ A ($V_{OUT}=3.0V$, $V_{IN}=5.0V$)
- Dropout Voltage Typ. 0.04V ($I_{OUT}=1mA$, $V_{OUT}=2.8V$)
- Input Voltage Range Max. 10.0V
- Output Voltage Range..... 2.0V to 6.0V (0.1V steps)
(For other voltages, please refer to MARK INFORMATIONS.)
- Output Voltage Accuracy..... $\pm 2.5\%$
- Temperature-Drift Coefficient of Output Voltage Typ. $\pm 100ppm/^{\circ}C$
- Line Regulation Typ. 0.05%/V
- Packages SOT-23-5 (Mini-mold), SOT-89 (Mini-power Mold),
TO-92 (**Discontinued**)

APPLICATIONS

- Power source for battery-powered equipment
- Power source for cameras, video instruments such as camcorders, VCRs, and hand-held communication equipment
- Precision voltage references

BLOCK DIAGRAMS

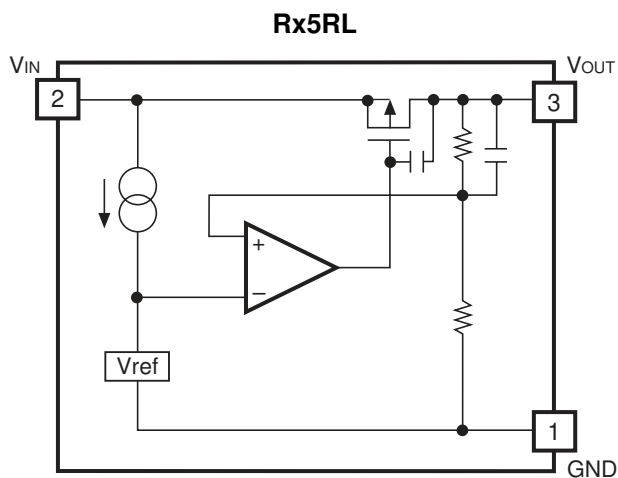

SELECTION GUIDE

The output voltage and package for the ICs can be selected at the user's request.

Product Name	Package	Quantity per Reel	Pb Free	Halogen Free
RN5RLxxAA-TR-FE	SOT-23-5	3,000 pcs	Yes	Yes
RH5RLxxAA-T1-FE	SOT-89	1,000 pcs	Yes	Yes
RE5RLxxAA-TR-F	TO-92 (Discontinued)	2,500 pcs	Yes	No

xx: The output voltage can be designated in the range from 2.0V (20) to 6.0V (60) in 0.1V steps.
(For other voltages, please refer to MARK INFORMATION.)

PIN CONFIGURATION

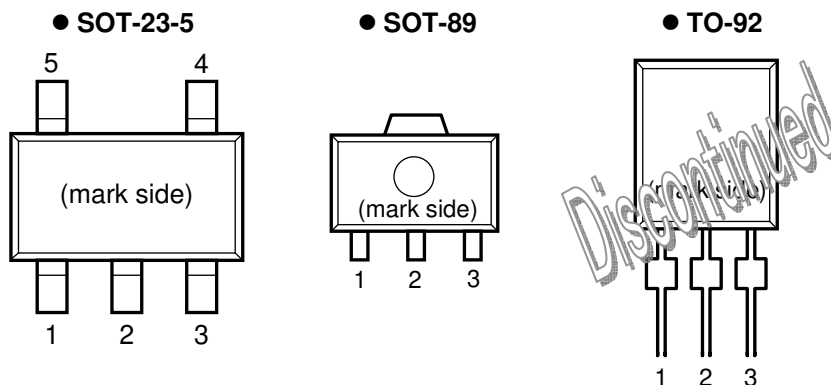

PIN DESCRIPTION

• SOT-23-5

Pin No	Symbol	Pin Description
1	GND	Ground Pin
2	V_{IN}	Input Pin
3	V_{OUT}	Output Pin
4	NC	No Connection
5	NC	No Connection

• SOT-89

Pin No	Symbol	Pin Description
1	GND	Ground Pin
2	V_{IN}	Input Pin
3	V_{OUT}	Output Pin

• TO-92 (Discontinued)

Pin No	Symbol	Pin Description
1	GND	Ground Pin
2	V_{IN}	Input Pin
3	V_{OUT}	Output Pin

ABSOLUTE MAXIMUM RATINGS

Symbol	Item	Rating	Unit
V_{IN}	Input Voltage	12	V
V_{OUT}	Output Voltage	-0.3 to $V_{IN}+0.3$	V
I_{OUT}	Output Current	150	mA
P_D	Power Dissipation* (SOT-23-5)	420	mW
	Power Dissipation* (SOT-89)	900	
	Power Dissipation* (TO-92) (Discontinued)	300	
T_{opt}	Operating Temperature Range	-40 to 85	°C
T_{stg}	Storage Temperature Range	-55 to 125	°C
T_{solder}	Lead Temperature (Soldering)	260°C, 10s	

*) For Power Dissipation, please refer to PACKAGE INFORMATION.

ABSOLUTE MAXIMUM RATINGS

Electronic and mechanical stress momentarily exceeded absolute maximum ratings may cause the permanent damages and may degrade the life time and safety for both device and system using the device in the field.

The functional operation at or over these absolute maximum ratings is not assured.

RECOMMENDED OPERATING CONDITIONS (ELECTRICAL CHARACTERISTICS)

All of electronic equipment should be designed that the mounted semiconductor devices operate within the recommended operating conditions. The semiconductor devices cannot operate normally over the recommended operating conditions, even if when they are used over such conditions by momentary electronic noise or surge. And the semiconductor devices may receive serious damage when they continue to operate over the recommended operating conditions.

ELECTRICAL CHARACTERISTICS

• Rx5RL20A

T_{opt}=25°C

Symbol	Item	Conditions	Min.	Typ.	Max.	Unit
V _{OUT}	Output Voltage	V _{IN} =4.0V 10μA≤I _{OUT} ≤10mA	1.950	2.000	2.050	V
I _{OUT}	Output Current	V _{IN} =4.0V	25	35		mA
$\frac{\Delta V_{OUT}}{\Delta I_{OUT}}$	Load Regulation	V _{IN} =4.0V 1mA≤I _{OUT} ≤35mA		30	45	mV
V _{DIF}	Dropout Voltage	I _{OUT} =1mA		60	90	mV
I _{SS}	Quiescent Current	V _{IN} =4.0V		1.0	3.0	μA
$\frac{\Delta V_{OUT}}{\Delta V_{IN}}$	Line Regulation	I _{OUT} =1mA V _{OUT} +0.5V≤V _{IN} ≤10V		0.05	0.20	%/V
V _{IN}	Input Voltage				10	V
$\frac{\Delta V_{OUT}}{\Delta T_{opt}}$	Output Voltage Temperature Coefficient	I _{OUT} =10mA -40°C≤T _{opt} ≤85°C		±100		ppm/°C

• Rx5RL30A

T_{opt}=25°C

Symbol	Item	Conditions	Min.	Typ.	Max.	Unit
V _{OUT}	Output Voltage	V _{IN} =5.0V 10μA≤I _{OUT} ≤10mA	2.925	3.000	3.075	V
I _{OUT}	Output Current	V _{IN} =5.0V	35	50		mA
$\frac{\Delta V_{OUT}}{\Delta I_{OUT}}$	Load Regulation	V _{IN} =5.0V 1mA≤I _{OUT} ≤50mA		40	60	mV
V _{DIF}	Dropout Voltage	I _{OUT} =1mA		40	60	mV
I _{SS}	Quiescent Current	V _{IN} =5.0V		1.1	3.3	μA
$\frac{\Delta V_{OUT}}{\Delta V_{IN}}$	Line Regulation	I _{OUT} =1mA V _{OUT} +0.5V≤V _{IN} ≤10V		0.05	0.20	%/V
V _{IN}	Input Voltage				10	V
$\frac{\Delta V_{OUT}}{\Delta T_{opt}}$	Output Voltage Temperature Coefficient	I _{OUT} =10mA -40°C≤T _{opt} ≤85°C		±100		ppm/°C

Rx5RL

• Rx5RL40A

T_{opt}=25°C

Symbol	Item	Conditions	Min.	Typ.	Max.	Unit
V _{OUT}	Output Voltage	V _{IN} =6.0V 10μA≤I _{OUT} ≤10mA	3.900	4.000	4.100	V
I _{OUT}	Output Current	V _{IN} =6.0V	45	65		mA
$\frac{\Delta V_{OUT}}{\Delta I_{OUT}}$	Load Regulation	V _{IN} =6.0V 1mA≤I _{OUT} ≤65mA		50	75	mV
V _{DIF}	Dropout Voltage	I _{OUT} =1mA		25	38	mV
I _{SS}	Quiescent Current	V _{IN} =6.0V		1.2	3.6	μA
$\frac{\Delta V_{OUT}}{\Delta V_{IN}}$	Line Regulation	I _{OUT} =1mA V _{OUT} +0.5V≤V _{IN} ≤10V		0.05	0.20	%/V
V _{IN}	Input Voltage				10	V
$\frac{\Delta V_{OUT}}{\Delta T_{opt}}$	Output Voltage Temperature Coefficient	I _{OUT} =10mA -40°C≤T _{opt} ≤85°C		±100		ppm/°C

• Rx5RL50A

T_{opt}=25°C

Symbol	Item	Conditions	Min.	Typ.	Max.	Unit
V _{OUT}	Output Voltage	V _{IN} =7.0V 10μA≤I _{OUT} ≤10mA	4.875	5.000	5.125	V
I _{OUT}	Output Current	V _{IN} =7.0V	55	80		mA
$\frac{\Delta V_{OUT}}{\Delta I_{OUT}}$	Load Regulation	V _{IN} =7.0V 1mA≤I _{OUT} ≤80mA		60	90	mV
V _{DIF}	Dropout Voltage	I _{OUT} =1mA		25	38	mV
I _{SS}	Quiescent Current	V _{IN} =7.0V		1.3	3.9	μA
$\frac{\Delta V_{OUT}}{\Delta V_{IN}}$	Line Regulation	I _{OUT} =1mA V _{OUT} +0.5V≤V _{IN} ≤10V		0.05	0.20	%/V
V _{IN}	Input Voltage				10	V
$\frac{\Delta V_{OUT}}{\Delta T_{opt}}$	Output Voltage Temperature Coefficient	I _{OUT} =10mA -40°C≤T _{opt} ≤85°C		±100		ppm/°C

• Rx5RL60A

T_{opt}=25°C

Symbol	Item	Conditions	Min.	Typ.	Max.	Unit
V _{OUT}	Output Voltage	V _{IN} =8.0V 10μA≤I _{OUT} ≤10mA	5.850	6.000	6.150	V
I _{OUT}	Output Current	V _{IN} =8.0V	55	80		mA
$\frac{\Delta V_{OUT}}{\Delta I_{OUT}}$	Load Regulation	V _{IN} =8.0V 1mA≤I _{OUT} ≤80mA		60	90	mV
V _{DIF}	Dropout Voltage	I _{OUT} =1mA		25	38	mV
I _{SS}	Quiescent Current	V _{IN} =8.0V		1.3	3.9	μA
$\frac{\Delta V_{OUT}}{\Delta V_{IN}}$	Line Regulation	I _{OUT} =1mA V _{OUT} +0.5V≤V _{IN} ≤10V		0.05	0.20	%/V
V _{IN}	Input Voltage				10	V
$\frac{\Delta V_{OUT}}{\Delta T_{opt}}$	Output Voltage Temperature Coefficient	I _{OUT} =10mA -40°C≤T _{opt} ≤85°C		±100		ppm/°C

ELECTRICAL CHARACTERISTICS BY OUTPUT VOLTAGE

Part Number	Output Voltage				Output Current			Load Regulation			Dropout Voltage		
	V _{OUT} (V)				I _{OUT} (mA)			ΔV _{OUT} (mV)			V _{DIF} (mV)		
	Conditions	Min.	Typ.	Max.	Conditions	Min.	Typ.	Conditions	Typ.	Max.	Conditions	Typ.	Max.
Rx5RL20A	V _{IN} - V _{OUT} =2.0V 10μA≤ I _{OUT} ≤10mA	1.950	2.000	2.050	V _{IN} - V _{OUT} =2.0V	25	35	V _{IN} - V _{OUT} =2.0V 1mA≤ I _{OUT} ≤35mA	30	45	I _{OUT} =1mA	60	90
Rx5RL21A		2.048	2.100	2.152									
Rx5RL22A		2.145	2.200	2.255									
Rx5RL23A		2.243	2.300	2.357									
Rx5RL24A		2.340	2.400	2.460									
Rx5RL25A		2.438	2.500	2.562									
Rx5RL26A		2.535	2.600	2.665									
Rx5RL27A		2.633	2.700	2.767									
Rx5RL28A		2.730	2.800	2.870									
Rx5RL29A		2.828	2.900	2.972									
Rx5RL30A		2.925	3.000	3.075									
Rx5RL31A		3.023	3.100	3.177									
Rx5RL32A		3.120	3.200	3.280									
Rx5RL33A		3.218	3.300	3.382									
Rx5RL34A		3.315	3.400	3.485									
Rx5RL35A		3.413	3.500	3.587									
Rx5RL36A		3.510	3.600	3.690									
Rx5RL37A		3.608	3.700	3.792									
Rx5RL38A		3.705	3.800	3.895									
Rx5RL39A		3.803	3.900	3.997									
Rx5RL40A		3.900	4.000	4.100									
Rx5RL41A		3.998	4.100	4.202									
Rx5RL42A		4.095	4.200	4.305									
Rx5RL43A		4.193	4.300	4.407									
Rx5RL44A		4.290	4.400	4.510									
Rx5RL45A		4.388	4.500	4.612									
Rx5RL46A		4.485	4.600	4.715									
Rx5RL47A		4.583	4.700	4.817									
Rx5RL48A		4.680	4.800	4.920									
Rx5RL49A		4.778	4.900	5.022									
Rx5RL50A	4.875	5.000	5.125										
Rx5RL51A	4.973	5.100	5.227										
Rx5RL52A	5.070	5.200	5.330										
Rx5RL53A	5.168	5.300	5.432										
Rx5RL54A	5.265	5.400	5.535										
Rx5RL55A	5.363	5.500	5.637										
Rx5RL56A	5.460	5.600	5.740										
Rx5RL57A	5.558	5.700	5.842										
Rx5RL58A	5.655	5.800	5.945										
Rx5RL59A	5.753	5.900	6.047										
Rx5RL60A	5.850	6.000	6.150										
												25	38
						45	65	V _{IN} - V _{OUT} =2.0V 1mA≤ I _{OUT} ≤65mA	50	70			
						35	50	V _{IN} - V _{OUT} =2.0V 1mA≤ I _{OUT} ≤50mA	40	60		35	53
												30	45

T_{opt}=25°C

Quiescent Current			Line Regulation			Input Voltage	Output Voltage Tempco.	
I _{SS} (μA)			ΔV _{OUT} /ΔV _{IN} (%/V)			V _{IN} (V)	ΔV _{OUT} /ΔT(ppm/°C)	
Conditions	Typ.	Max.	Conditions	Typ.	Max.	Max.	Conditions	Typ.
V _{IN} V _{OUT} =2.0V	1.0	3.0	I _{OUT} =1mA V _{OUT} + 0.5V≤ V _{IN} ≤ ≤10V	0.05	0.2	10	I _{OUT} =10mA -40°C≤ T _{opt} 85°C	±100
	1.1	3.3						
	1.2	3.6						
	1.3	3.9						

OPERATION

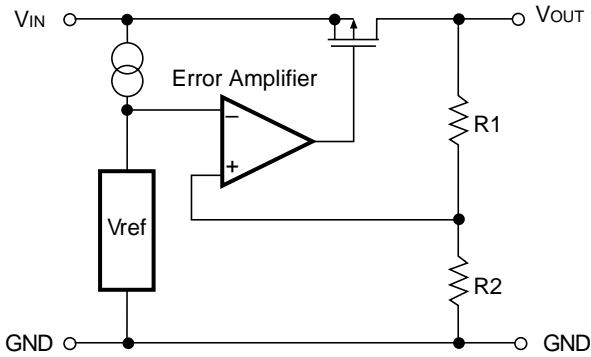

FIG. 1 Block Diagram

Output voltage, V_{OUT} divided at the node between Registers R1 and R2 is compared with the reference voltage by the error amplifier, so that a constant voltage is output.

TEST CIRCUITS

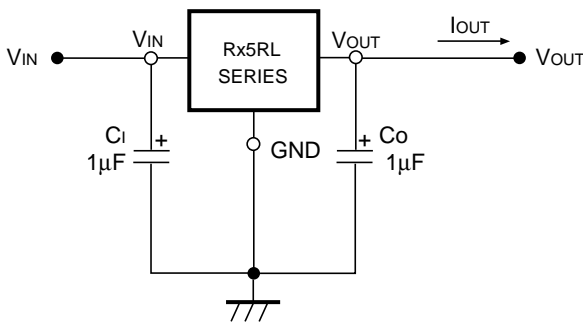

FIG. 2 Test Circuit

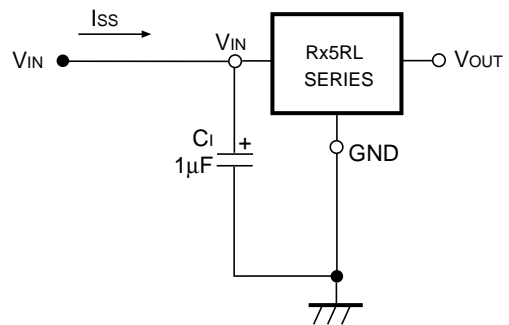

FIG. 3 Quiescent Current Test Circuit

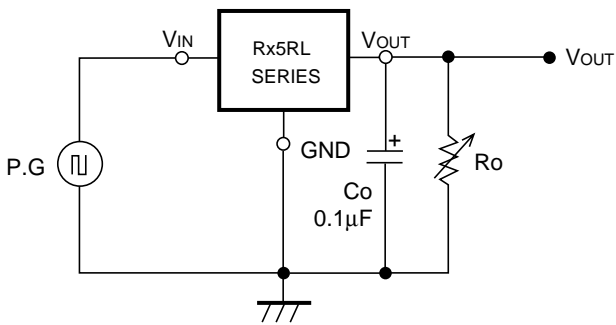
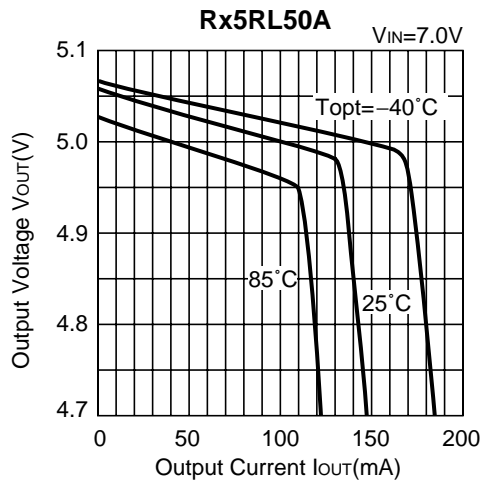
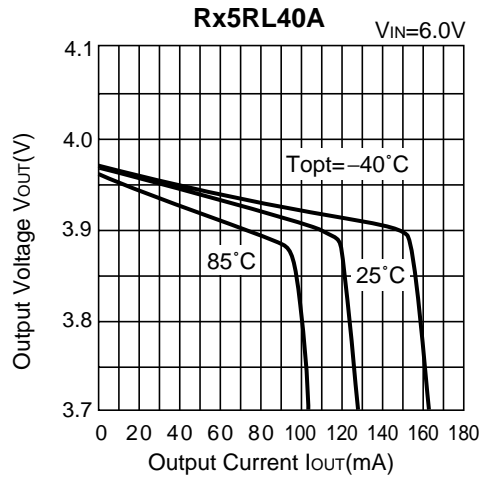
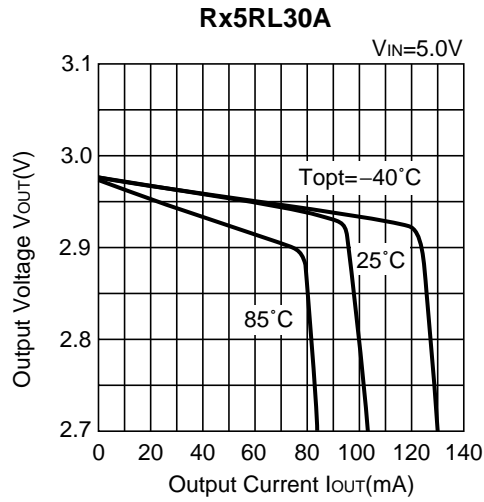

FIG. 4 Line Transient Response Test Circuit

TYPICAL CHARACTERISTICS

1) Output Voltage vs. Output Current



2) Output Voltage vs. Input Voltage

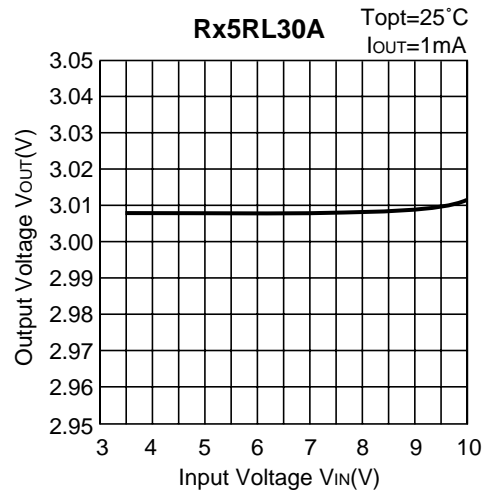
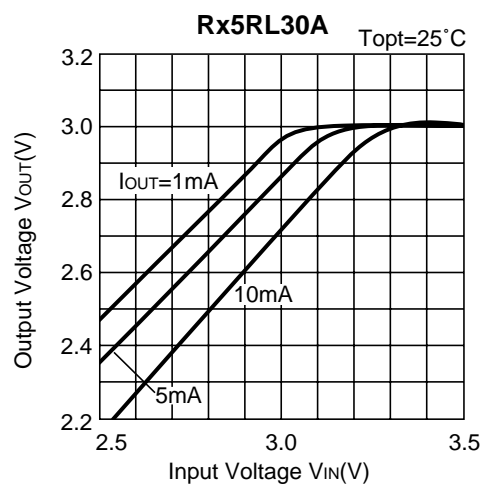

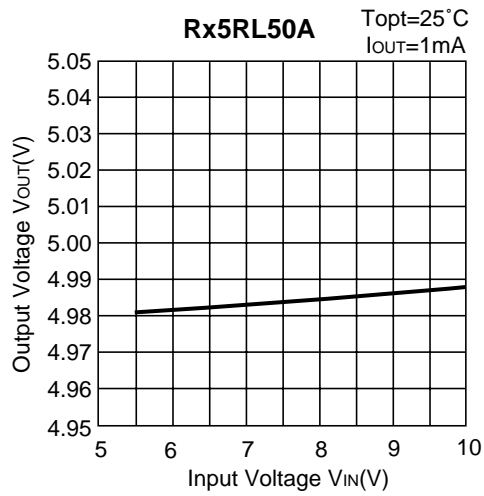
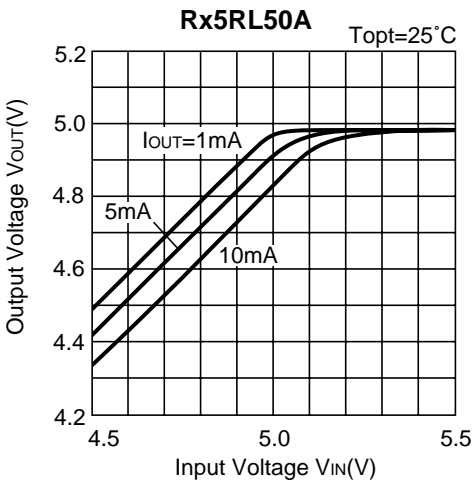
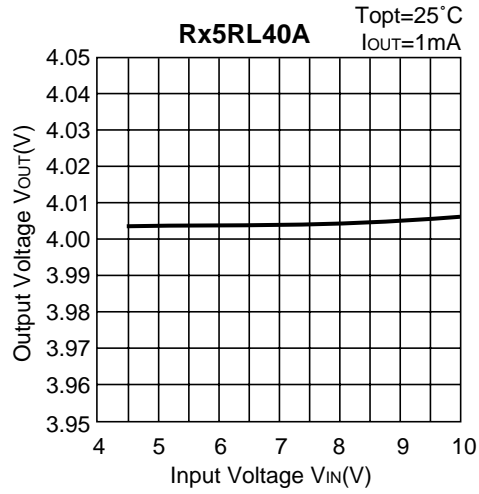
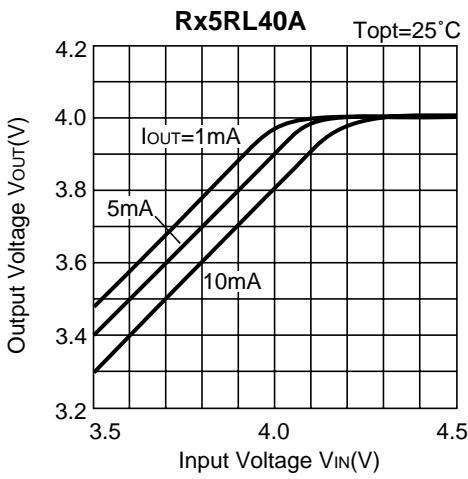

3) Dropout Voltage vs. Output Current

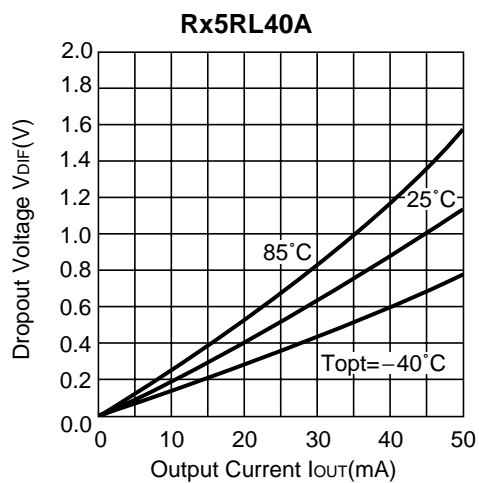
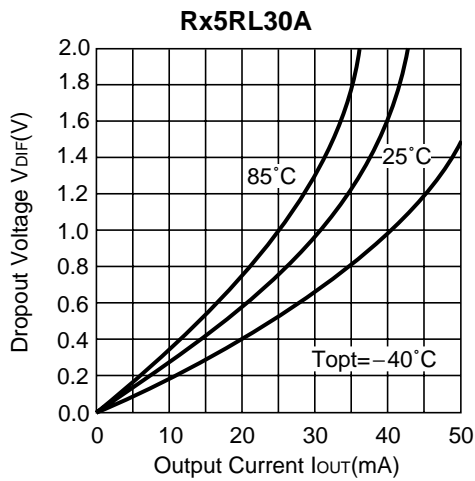

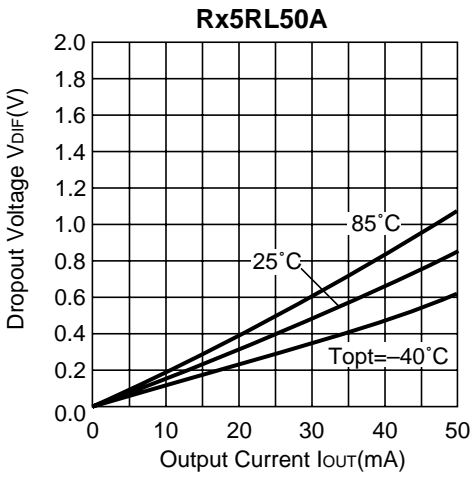

4) Output Voltage vs. Temperature

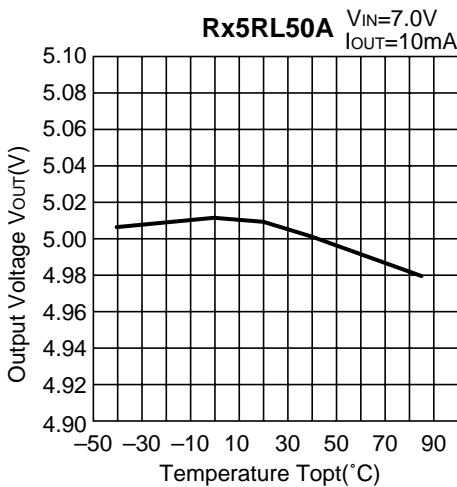
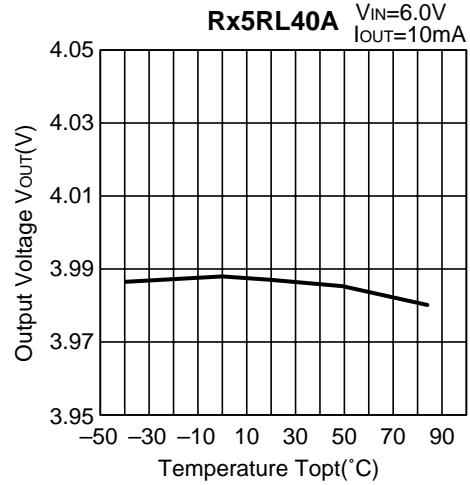
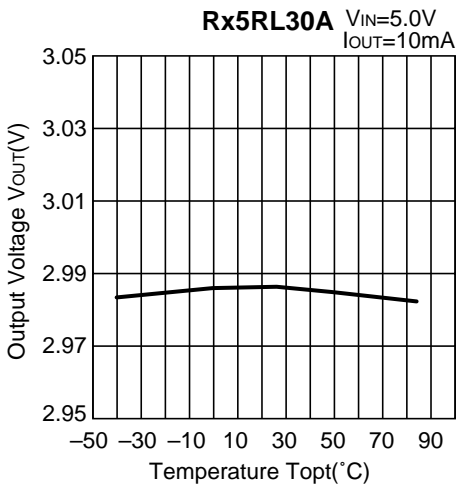

5) Quiescent Current vs. Input Voltage

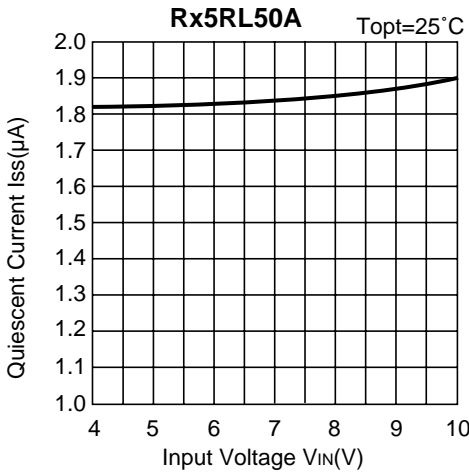
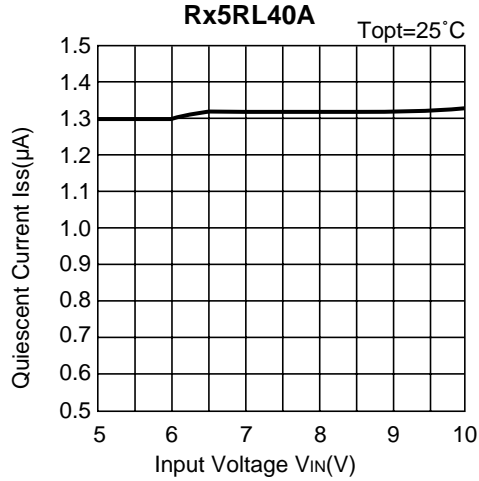
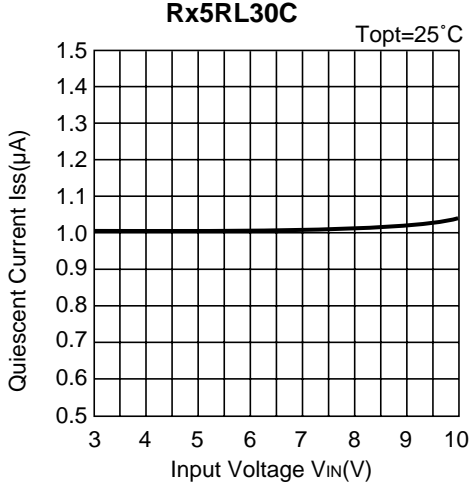

6) Quiescent Current vs. Temperature

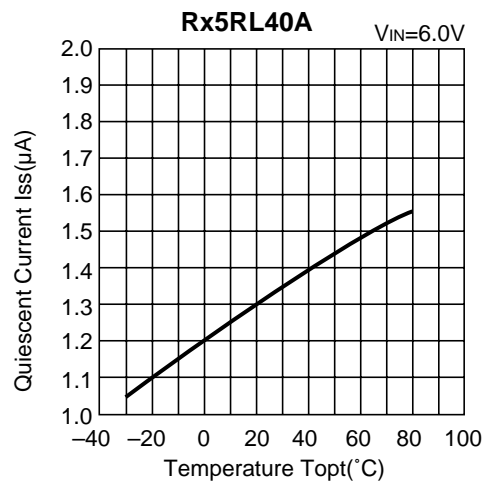
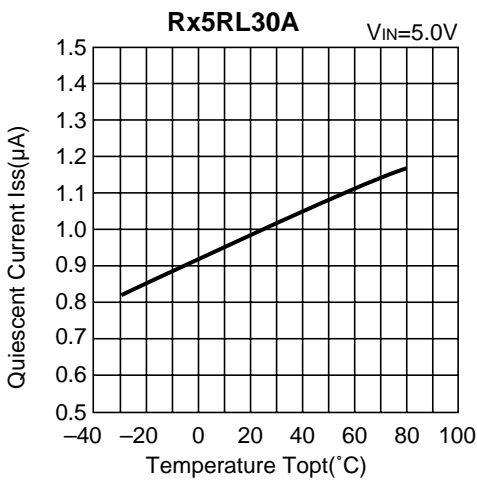

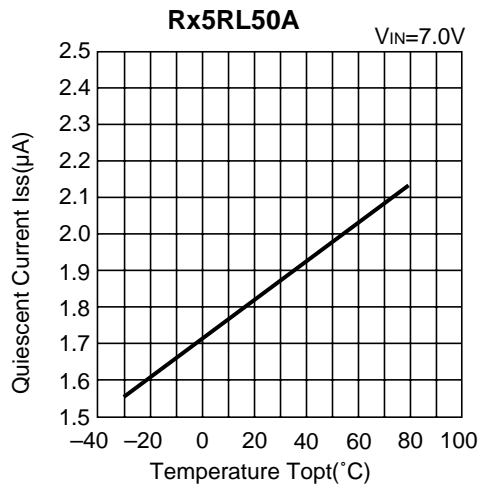

7) Dropout Voltage vs. Set Output Voltage

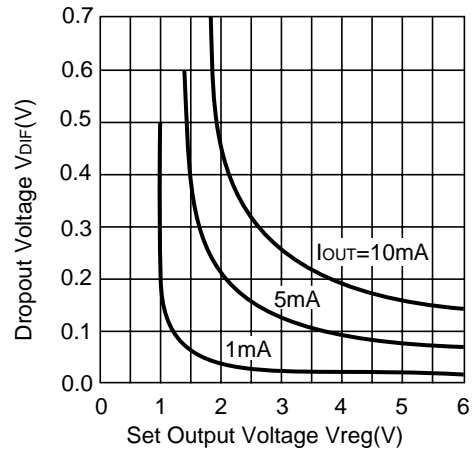

8) Line Transient Response (1)

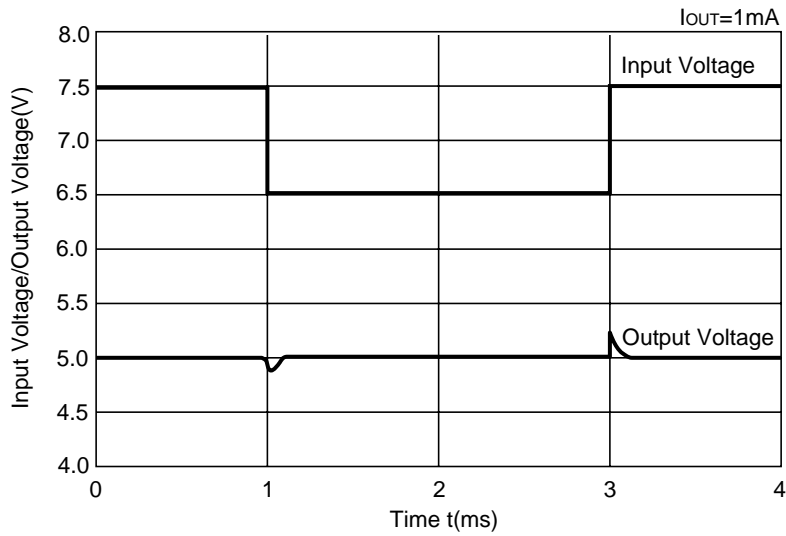

9) Line Transient Response (2)

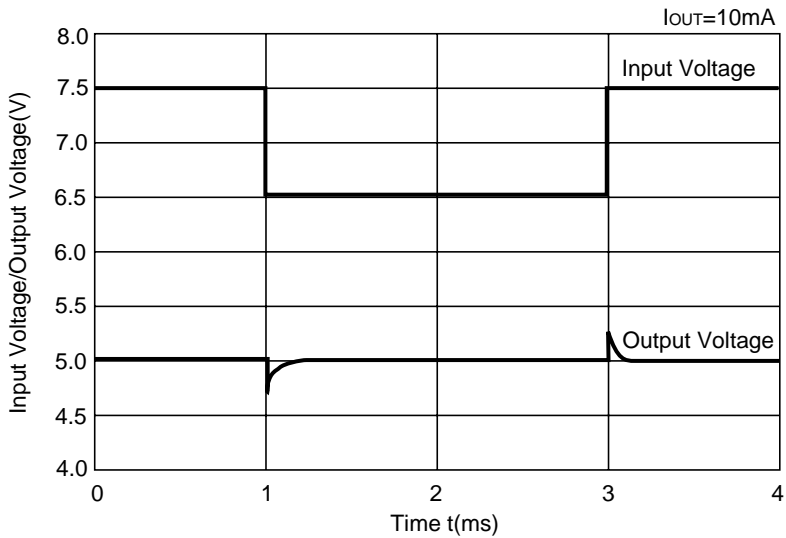

TYPICAL APPLICATION

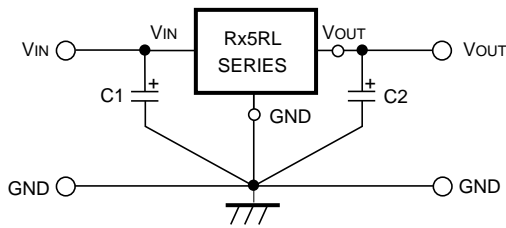

In Rx5RL Series, a constant voltage can be obtained without using Capacitors C1 and C2. However, when the wire connected to Vin is long, use Capacitor C1. Output noise can be reduced by using Capacitor C2.

Insert Capacitors C1 and C2 with the capacitance of 0.1μF to 2.0μF between Input/Output Pins and GND Pin with minimum wiring.

APPLICATION CIRCUITS

• VOLTAGE BOOST CIRCUIT

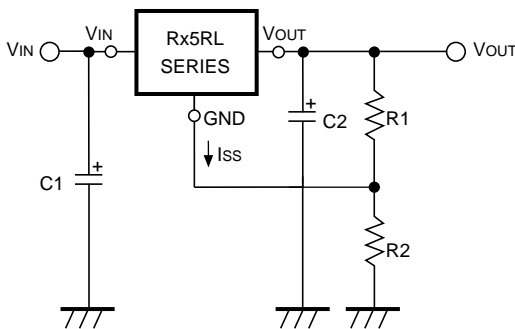

The output voltage can be obtained by the following formula :

$$V_{OUT} = V_{reg}^{*1} \cdot (1 + R2/R1) + I_{SS} R \cdot 2$$

Since the quiescent current of Rx5RE Series is so small that the resistances of R1 and R2 can be set as large as several hundreds kΩ and therefore the supply current of “Voltage Boost Circuit” itself can be reduced.

Furthermore, since Rx5RL Series are operated by a constant voltage, the supply current of “Voltage Boost Circuit” is not substantially affected by the input voltage.

■ *1) Vreg : Set Output Voltage of Rx5RL Series.

• DUAL POWER SUPPLY CIRCUIT

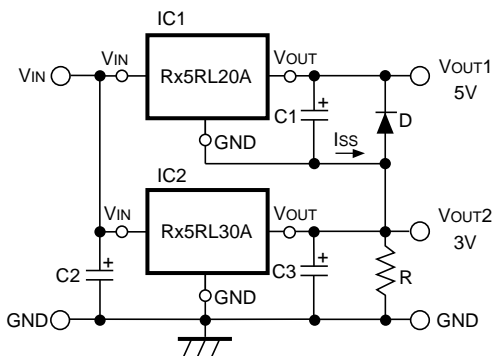

As shown in the circuit diagram, a dual power supply circuit can be constructed by using two Rx5RL Series.

This circuit diagram shows a dual power supply circuit with an output of 3V and an output of 5V. When the minimum output current of IC2 is larger than Iss of IC1, Resistor R is unnecessary. Diode D is a protection diode for the case where VOUT2 becomes larger than VOUT1.

• CURRENT BOOST CIRCUIT

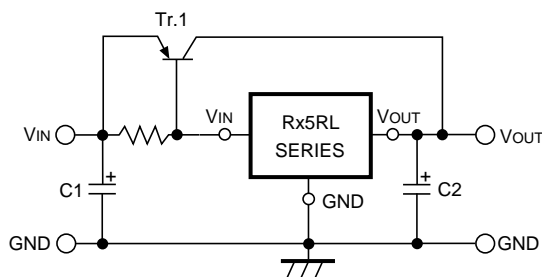

Output current of 60mA or more can be obtained by the current boost circuit constructed as shown in this circuit diagram.

• CURRENT BOOST CIRCUIT WITH OVERCURRENT LIMIT CIRCUIT

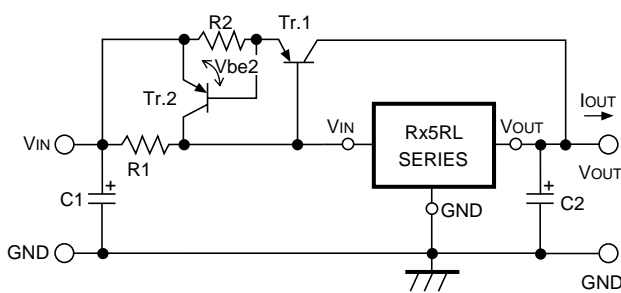

A circuit for protecting Tr.1 from the destruction caused by output short-circuit or overcurrent is shown in this circuit diagram.

When the voltage reduction caused by the current ($\approx I_{OUT}$) which flows through R2 reaches V_{be2} of Tr.2 by additionally providing the current boost circuit with Tr.2 and R2, Tr.2 is turned on and the base current of Tr.1 is increased, so that the output current is limited.

Current limit of overcurrent limit circuit is obtained as follows :

$$I_{OUT} \approx V_{be2}/R2$$

• CURRENT SOURCE

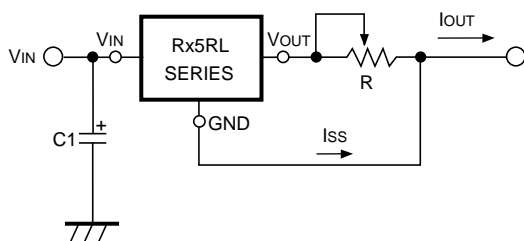

A current source with the structure as shown in this circuit diagram can be used. Output Current I_{OUT} is obtained as follows :

$$I_{OUT} = V_{reg}^{*1}/R + I_{SS}$$

Output current, I_{OUT} should not exceed its allowable current.

*1) V_{reg} : Set output voltage of Rx5RL Series.



1. The products and the product specifications described in this document are subject to change or discontinuation of production without notice for reasons such as improvement. Therefore, before deciding to use the products, please refer to our sales representatives for the latest information thereon.
2. The materials in this document may not be copied or otherwise reproduced in whole or in part without prior written consent of our company.
3. Please be sure to take any necessary formalities under relevant laws or regulations before exporting or otherwise taking out of your country the products or the technical information described herein.
4. The technical information described in this document shows typical characteristics of and example application circuits for the products. The release of such information is not to be construed as a warranty of or a grant of license under our company's or any third party's intellectual property rights or any other rights.
5. The products listed in this document are intended and designed for use as general electronic components in standard applications (office equipment, telecommunication equipment, measuring instruments, consumer electronic products, amusement equipment etc.). Those customers intending to use a product in an application requiring extreme quality and reliability, for example, in a highly specific application where the failure or misoperation of the product could result in human injury or death (aircraft, spacevehicle, nuclear reactor control system, traffic control system, automotive and transportation equipment, combustion equipment, safety devices, life support system etc.) should first contact us.
6. We are making our continuous effort to improve the quality and reliability of our products, but semiconductor products are likely to fail with certain probability. In order to prevent any injury to persons or damages to property resulting from such failure, customers should be careful enough to incorporate safety measures in their design, such as redundancy feature, fire containment feature and fail-safe feature. We do not assume any liability or responsibility for any loss or damage arising from misuse or inappropriate use of the products.
7. Anti-radiation design is not implemented in the products described in this document.
8. The X-ray exposure can influence functions and characteristics of the products. Confirm the product functions and characteristics in the evaluation stage.
9. WLCSP products should be used in light shielded environments. The light exposure can influence functions and characteristics of the products under operation or storage.
10. There can be variation in the marking when different AOI (Automated Optical Inspection) equipment is used. In the case of recognizing the marking characteristic with AOI, please contact our sales or our distributor before attempting to use AOI.
11. Please contact our sales representatives should you have any questions or comments concerning the products or the technical information.



Nisshinbo Micro Devices Inc.

Official website

<https://www.nisshinbo-microdevices.co.jp/en/>

Purchase information

<https://www.nisshinbo-microdevices.co.jp/en/buy/>

