

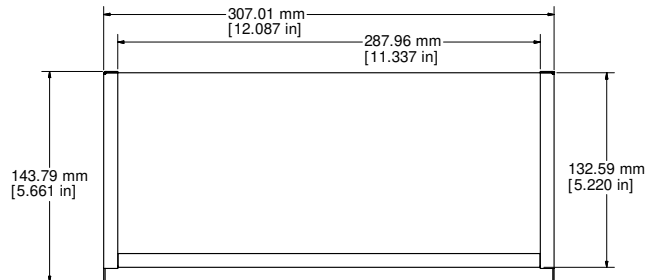

TOP VIEW OF ASSEMBLY



SIDE VIEW OF ASSEMBLY

.91 mm
[.036 in]
TYP. MATERIAL
THICKNESS

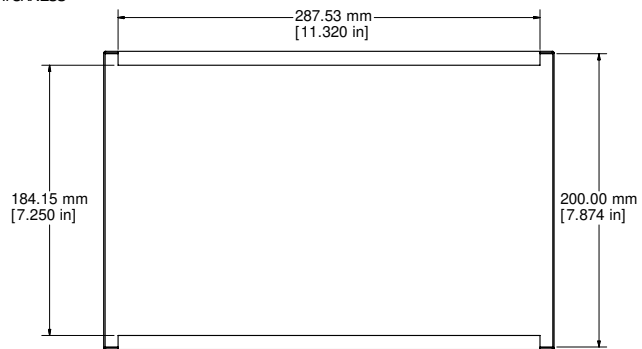

BOTTOM VIEW OF ASSEMBLY

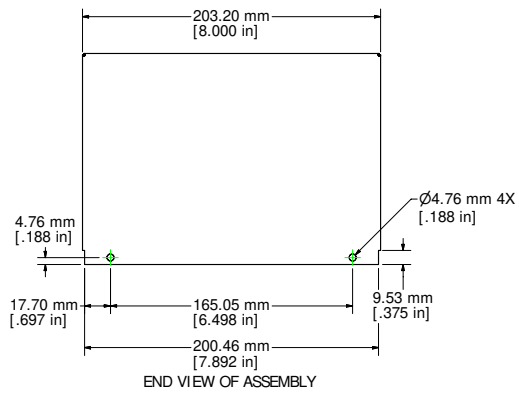

END VIEW OF ASSEMBLY

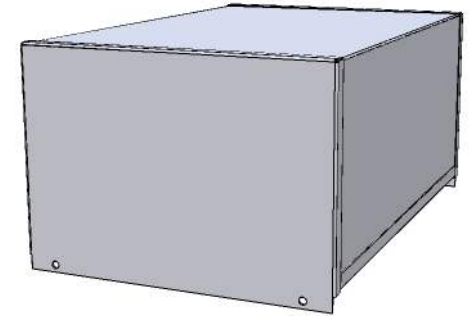

Note:

Enclosures can be Factory Modified (Milling, Drilling, Printing etc.)
 Contact Factory mjm@hammondmfg.com for quotes
 Solid models of this enclosure available in STEP or IGES Format.

1451-22
Material: 20ga. Welded Steel, Gray color
Cover: Perforated Steel
Screws: 4 Supplied (#6-32 X 1/4" self tap)
For use with 1441 and 1444 series chassis.



HAMMOND
MANUFACTURING™

1451-22

www.hammondmfg.com